

# 2021

SPM KSSM

## TINGKATAN 4

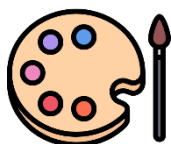

### MODUL FIZIK

# DIY

MENGANDUNGI

4

KEMAHIRAN

6

BIDANG  
PEMBELAJARAN

**SABAH  
HEBAT!**

Katakan Tidak kepada Nombor 16



KEMENTERIAN PENDIDIKAN MALAYSIA  
Jabatan Pendidikan Negeri Sabah

GURU FIZIK NEGERI SABAH

# Prakata



**MARCUS KHOO**

SM LOK YUK KOTA KINABALU (CF)

The past year has truly been a very tumultuous one, for both teachers and students. The SPM 2021 batch this year faces a new exam format (amongst many other challenges), and there is a need for teachers to pool their resources together to help our students to face what is ahead.

The 2021 edition of the Physics Module from JPN Sabah has been purposefully separated to 4 components, in order to give teachers and students a better focus on how to cater the use of the module for their own students. You will find the following in this year's edition:

1. Modul Fizik DIY Tingkatan 4
2. Modul Fizik DIY Tingkatan 5
3. Modul Kuantum Kertas 3
4. Modul Simulasi Impetus Physics

This year's module also sees the contribution of both experienced and new Physics teachers from all over Sabah. Since no one actually knows how the SPM paper under the new format will look like, we hope that the diversity in our experience serves as an added advantage for our students. I would like to thank all the team members for pouring out your effort and expertise into this module. I am especially grateful to Mr. Lee Chee Wei, Mdm. Chin Sok Hong and Mdm. Betty Duis who have gone above and beyond to ensure the completion of this module.

A special word of thanks also goes to our Sabah Education Department Director and also Heads of Sectors and officers in the Sabah Education Department (especially Mr. Faizal Norwen) who have given us their trust for the 2021 module. We also remember our District Education Officers, principals and fellow colleagues. Your support means the world to us.

Finally, to our students, we hope that this module will serve as an aid to your preparations for the Physics SPM paper. Please know that our thoughts and prayers go before you, and we hope that you will be able to find peace and encouragement in God as you prepare for your exams. All the best to you!

# PANEL PENGGUBAL MODUL FIZIK DIY TINGKATAN 4 DAN 5



**MARCUS KHOO HIOK TIAN (KETUA)**

- SM Lok Yuk Kota Kinabalu (CF)
- Sarjana Muda Sains dengan Pendidikan (Fizik/Matematik) (UM)
- Sarjana Pendidikan (Pendidikan Sains (UKM)
- Guru Cemerlang Fizik
- 16 tahun



**AHMADTANG BIN BOLONG**

- SMK Silabukan, Lahad Datu
- Sarjana Muda Pendidikan Dengan Kepujian (Fizik) (UKM)
- Guru Fizik
- 2 tahun



**AIRAN BINTI AWANG**

- SMK Taun Gusi II, Kota Belud
- Sarjana Muda Sains Dengan Kepujian (UMS)
- Guru Fizik
- 2 tahun



**AMIE JOAN JUANIS**

- SMK Langkon, Kota Marudu
- Sarjana Muda Pendidikan dengan Sains (UMS)
- Sarjana Pendidikan Matematik (UPSI)
- Guru Fizik
- 8 tahun



**ANNIE WONG SIONG HUNG**

- SMK Tansau, Penampang
- Sarjana Muda Sains serta Pendidikan (Fizik/ Matematik) (UTM)
- Guru Fizik
- 17 tahun



**BETTY DUIS**

- SMK Entilibon, Telupid
- Sarjana Muda Pendidikan dengan Sains (UMS)
- Guru Fizik
- 10 tahun



**CHIN SOK HONG**

- SMK Agaseh, Lahad Datu
- Sarjana Muda Sains dengan Pendidikan (USM)
- Guru Fizik
- 18 tahun



**CLARENA JOACHIM**

- SMK Apin-Apin, Keningau
- Sarjana Muda Pendidikan Kimia dengan Kepujian (UPSI)
- Sarjana Pendidikan (Sains) (UMS)
- Guru Fizik
- 6 tahun



**ELLISON DANNY LEINSIN**

- SMK Bandau, Kota Marudu
- Sarjana Muda Sains serta Pendidikan (Fizik) (UTM)
- Guru Fizik
- 11 tahun

# PANEL PENGGUBAL MODUL FIZIK DIY TINGKATAN 4 DAN 5



**HANAFIAH BIN EDDY CHONG JUNAIRI**

- SMK Ulu Sapi, Telupid
- Sarjana Muda Pendidikan (Kepujian) (Matematik) (UNIRAZAK)
- Sarjana Pendidikan (Multimedia) (UPSI)
- Guru Fizik
- 1 tahun



**IDREYANNA BINTI IDRUS**

- SMK Bahang, Penampang
- Sarjana Muda Kejuruteraan (Awam) (UNIMAS)
- Diploma Pendidikan (KPLI) (Maktab Gaya)
- Guru Fizik
- 1 tahun



**INDOTANG BINTI MUSA**

- SMK Kunak, Kunak
- Sarjana Muda Sains dengan Kepujian (UKM)
- Diploma Perguruan, Maktab Perguruan Temenggong Ibrahim
- KB Sains dan Matematik, Guru Fizik
- 19 tahun



**JAMES BOYD JOWSIP**

- SMK Takis, Papar
- Sarjana Muda Sains dan Pengurusan Sumber Haiwan (UNIMAS)
- Diploma Pendidikan (DPLI) (UPSI)
- Guru Fizik
- 12 tahun



**JECKLIN ISHAK**

- SMK Desa Wawasan, Tambunan
- Sarjana Muda Pendidikan dengan Sains (Fizik) (UMS)
- Guru Fizik
- 8 tahun



**KEVVY BIN SIMON**

- SMK Nabawan, Pensiangan
- Sarjana Muda Pendidikan (Matematik/Fizik) (UMS)
- Guru Fizik
- 1 tahun



**LINDY MARCUS**

- SMK Beluran, Beluran
- Sarjana Muda Pendidikan Sains dengan Kepujian (Fizik) (UPSI)
- KB Sains dan Matematik, Guru Fizik
- 12 tahun



**LISA POLUS MASUNDANG**

- SM St Anthony, Tenom
- Sarjana Muda Pendidikan dengan Sains (Matematik/Fizik) (UMS)
- Sarjana Pendidikan Sains (Fizik) (UMS)
- KB Sains dan Matematik, Guru Fizik
- 11 tahun



**MARIA HENDRIKUS**

- SMK Kuala Penyu, Kuala Penyu
- Sarjana Muda Sains Fizik Gunaan (UKM)
- Diploma Pendidikan Fizik (UKM)
- Guru Fizik
- 18 tahun



**NOOR ALLFIZAN BIN GAMILIN**

- SMK Tongod, Telupid
- Sarjana Muda Pendidikan dengan Kepujian (Fizik) (UITM)
- Guru Fizik
- 5 tahun

# PANEL PENGGUBAL MODUL FIZIK DIY TINGKATAN 4 DAN 5



**NORLIE@DAYANG NORLIE BINTI  
MASRIN**

- SMK Pitas II, Pitas
- Sarjana Muda Pendidikan dengan Sains (Kepujian) (UMS)
- Guru Fizik
- 10 tahun



**NUR AAINAA BINTI MUHAMMAD**

- SMK Kudat II
- Sarjana Muda Sains serta Pendidikan (Matematik) (UTM)
- Guru Fizik
- 8 tahun



**RAHMAN BIN LAMANTE**

- SMK Lohan, Ranau
- Sarjana Muda Pendidikan dengan Sains (UMS)
- Guru Fizik
- 12 tahun



**RAYMOND MAININ**

- SMK TELUPID
- Sarjana Muda Pendidikan dengan Kepujian (Sains) (UMS)
- Guru Fizik
- 1 tahun



**RUKIAH BINTI ABDULLAH**

- SMK Pitas
- Sarjana Muda Pendidikan dengan Sains (UMS)
- Guru Fizik
- 9 tahun



**SAMSUL JUWAIT**

- SMK Penangah, Tongod, Telupid
- Bachelor of Science (Physics) University of Warwick, UK
- Guru Fizik
- 10 tahun



**SITI BAIZURAH BINTI AWANG  
KECHIL**

- SMK Bukit Garam, Kinabatangan
- Sarjana Muda Pendidikan dengan Kepujian (Sains/Matematik)
- Guru Fizik
- 1 tahun



**VALERIE ALEXIUS**

- SM St. James Tenghilan, Tuaran
- Sarjana Muda Pendidikan dengan Kepujian (Sains) (UMS)
- Sarjana Pendidikan (Pendidikan Sains) (UMS)
- Guru Fizik
- 10 tahun

# ISI KANDUNGAN

## **PENGENALAN**

Isi Kandungan Modul Fizik DIY T4 **2**

## **PENGETAHUAN / KEFAHAMAN / APLIKASI**

Bab 1 – 6 **3**

## **MENGGONSEPSI**

Bab 1 – 6 **48**

## **MEMBUAT KEPUTUSAN**

Bab 1 – 6 **84**

## **MENYELESAIKAN MASALAH**

Bab 1 – 6 **117**

## **SKEMA JAWAPAN**

Pengetahuan / Kefahaman / Aplikasi **145**

Mengkonsepsi **168**

Membuat Keputusan **184**

Menyelesaikan Masalah **201**

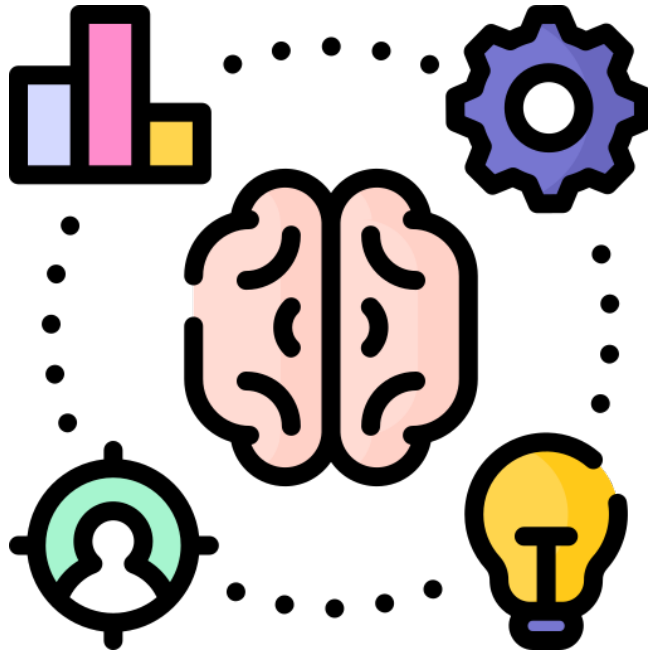

**KEMAHIRAN** : PENGETAHUAN /  
KEFAHAMAN / APLIKASI

**ELEMENT** : KNOWLEDGE /  
COMPREHENSION / APPLICATION

# BAB 1 : PENGUKURAN / CHAPTER 1 : MEASUREMENT

## BAHAGIAN A / SECTION A

- 1 Rajah 1 menunjukkan skala termometer.

*Diagram 1 shows the scale of a thermometer.*

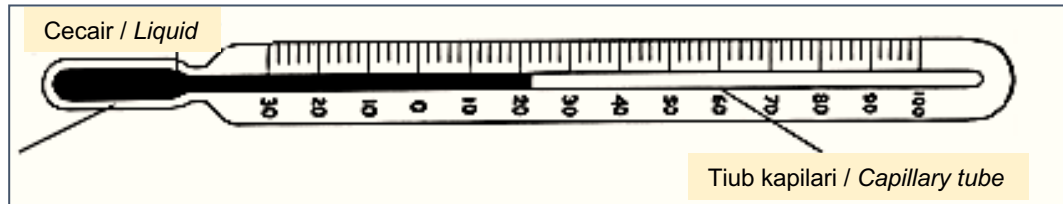

Rajah 1 / Diagram 1

- (a) Namakan kuantiti fizik yang diukur oleh termometer.

*Name the physical quantity measured by the thermometer.*

---

[1 markah / 1 mark]

- (b) Apakah nilai skala terkecil bagi skala termometer tersebut?

*What is the value of the smallest division of the thermometer scale?*

---

[1 markah / 1 mark]

- (c) Apakah bacaan termometer tersebut dalam unit darjah celsius?

*What is the reading of the thermometer in degree celsius?*

---

[1 markah / 1 mark]

- (d) Nyatakan cecair yang sesuai digunakan di dalam termometer.

*State the suitable liquid to be used in the thermometer.*

---

[1 markah / 1 mark]

- 2 Rajah 2.1 menunjukkan angkup vernier yang digunakan untuk mengukur ketebalan,  $d$  sebuah buku dalam Rajah 2.2.

*Diagram 2.1 shows a Vernier calliper used to measure the thickness,  $d$  of a book in Diagram 2.2.*

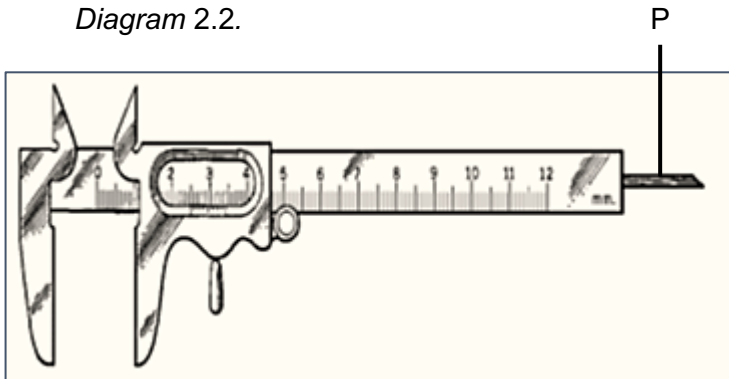

Rajah 2.1 / Diagram 2.1

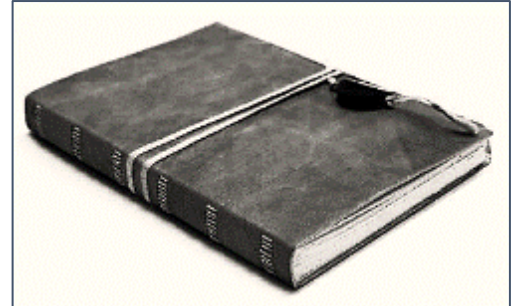

Rajah 2.2 / Diagram 2.2

Jadual 1 di bawah menunjukkan ukuran yang diperolehi

*Table 1 below shows the measurement obtained*

<b>Kuantiti diukur</b> <i>Measured quantity</i>	<b>Bacaan</b> <i>Reading</i>
Ketebalan bagi 100 helai kertas, $d$ <i>Thickness of 100 pieces of paper, <math>d</math></i>	0.82 cm

Jadual 1 / Table 1

- (a) Nyatakan kepekaan bagi angkup vernier.

*State the sensitivity of the vernier calliper.*

---

[1 markah / 1 mark]

- (b) Hitungkan ketebalan bagi sehelai kertas

*Calculate the thickness of a piece of a paper*

[2 markah / 2 marks]

(c) Namakan bahagian berlabel P.

*Name the part label P.*

---

[1 markah / 1 mark]

(d) Namakan satu alat pengukur yang lebih peka berbanding angkup vernier.

*State a measuring instrument that is more sensitive than a vernier calliper?*

---

[1 markah / 1 mark]

3 Rajah 3 menunjukkan sebuah alat pengukur yang digunakan dalam satu litar elektrik.

*Diagram 3 shows a measuring instrument used in an electric circuit.*

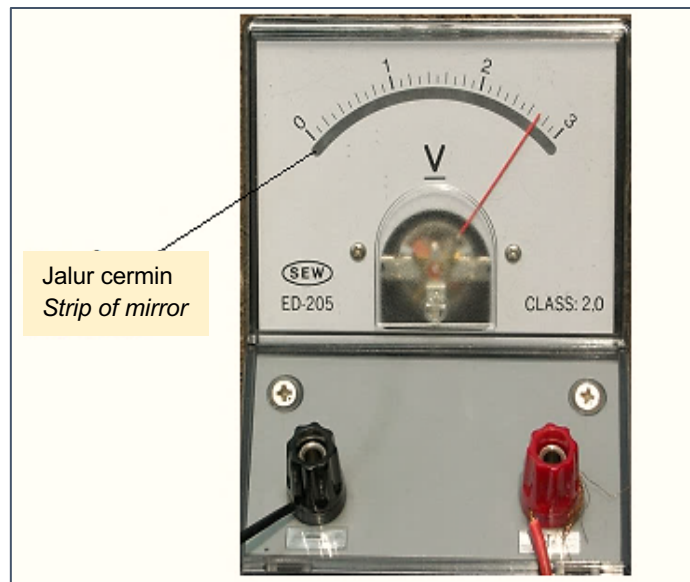

Rajah 3 / Diagram 3

(a) Namakan alat pengukuran yang ditunjukkan dalam Rajah 3

*Name the measuring instrument shows in Diagram 3*

---

[1 markah / 1 mark]

(b) Apakah kuantiti fizik yang diukur oleh alat pengukur dalam Rajah 3?

*What is the physical quantity measured by the instrument in Diagram 3?*

---

[1 markah / 1 mark]

- (c) Berapakah bacaan alat pengukur itu?  
*What is the reading of the instrument?*

---

[1 markah / 1 mark]

- (d) State the type of connection made in an electric circuit when the instrument is used.  
*Nyatakan jenis sambungan alat pengukur itu dalam satu litar elektrik ketika membuat pengukuran.*

---

[1 markah / 1 mark]

- (e) State the function of the strip of mirror.  
*Nyatakan kegunaan jalur cermin pada alat pengukur itu.*

---

[2 markah / 2 marks]

- 4 Rajah 4.1 menunjukkan bacaan awal jam randik pada awal suatu eksperimen. Jam randik ini digunakan untuk mengukur masa 20 ayunan lengkap yang dilakukan oleh satu bandul ringkas yang panjangnya,  $l$ . Rajah 4.2 menunjukkan bacaan jam randik itu pada akhir eksperimen.

*Diagram 4.1 shows the initial reading of a stopwatch at the beginning of an experiment. The stopwatch was used to measure the time for 20 complete oscillations made by a simple pendulum of length,  $l$ . Diagram 4.2 shows the reading of the stopwatch at the end of the experiment.*

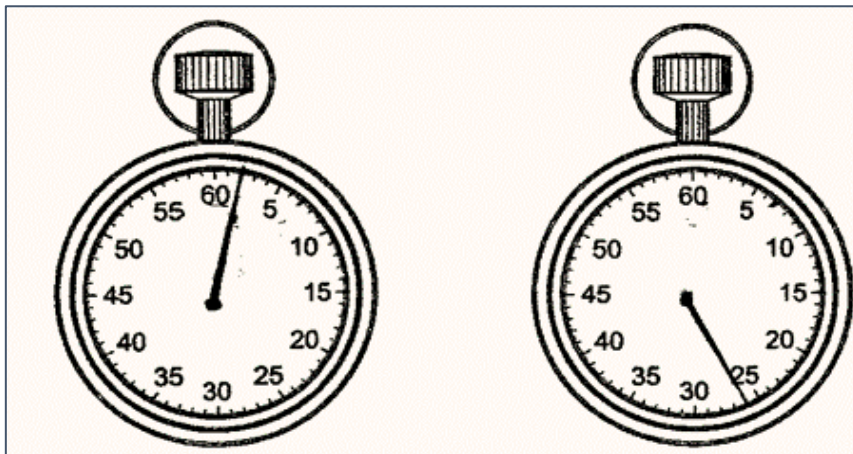

Rajah 4.1 / Diagram 4.1

Rajah 4.2 / Diagram 4.2

- (a) (i) Nyatakan jenis ralat yang ditunjukkan pada Rajah 4.1 dan cara mengatasinya.  
*State the type of error shown in Diagram 4.1 and the way to overcome it.*

---

---

[2 markah / 2 marks]

- (ii) Nyatakan nilai ralat yang ditunjukkan pada Rajah 4.1  
*State the value of error shown in Diagram 4.1*

---

[1 markah / 1 mark]

- (iii) Berapakah masa sebenar yang diambil oleh bandul itu untuk melengkapkan 20 ayunan?  
*What is the actual time taken for the pendulum to complete 20 oscillations?*

[2 marks / 2 markah]

- (b) (i) Tentukan tempoh **satu** ayunan lengkap,  $T$ , bagi bandul ini.  
*Find the period of **one** complete oscillation,  $T$ , for this pendulum.*

[2 markah / 2 marks]

- (ii) Hubungan antara panjang,  $l$ , dan tempoh,  $T$ , satu bandul ringkas diberikan oleh persamaan,

$$l = \left( \frac{g}{4\pi^2} \right) T^2$$

*The relationship between the length,  $l$ , and the period,  $T$ , of a simple pendulum is given by the equation,*

$$l = \left( \frac{g}{4\pi^2} \right) T^2$$

Dengan menggunakan nilai  $T$  dalam (b)(i), hitungkan panjang,  $l$  bandul itu.

[Diberi bahawa  $\pi = 3.142$  dan  $g = 10 \text{ m s}^{-2}$ ]

*Using the value of  $T$  obtained in (b)(i), calculate the length,  $l$ , of the pendulum.*

*[Given that  $\pi = 3.142$  and  $g = 10 \text{ m s}^{-2}$ ]*

[2 markah / 2 marks]

## BAHAGIAN B DAN C / SECTION B AND C

- 1 (a) (i) Nyatakan dua fungsi graf.

*State two functions of graphs.*

[2 markah / 2 marks]

- (ii) Bacaan atau pemerhatian direkodkan di dalam jadual, nyatakan tiga ciri utama semasa merekod dan mencatat data atau pemerhatian.

*Readings and observations are record in a table, state three important characteristics while recording and taking data or observations.*

[3 markah / 3 marks]

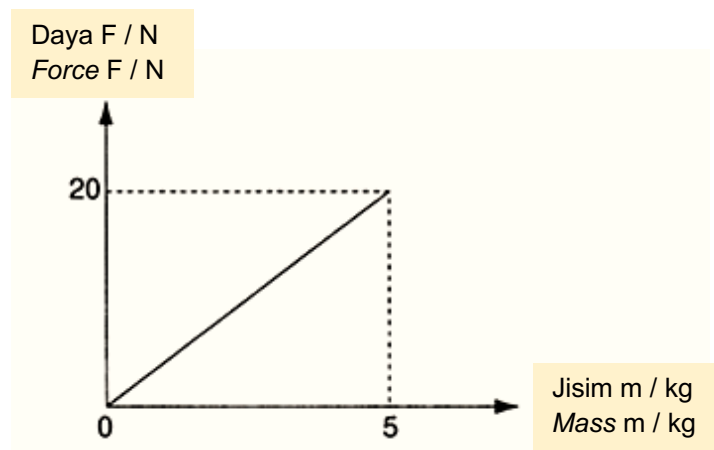

Rajah 1 / Diagram 1

- (b) Berdasarkan Rajah 1, nyatakan :

*Based on Diagram 1, state :*

- (i) Pembolehubah yang dimanipulasikan dan bergerak balas.

*The manipulated variable and responding variable.*

[2 markah / 2 marks]

- (ii) Hubungan di antara daya,  $F$  dengan jisim,  $m$ .

*The relationship between the force,  $F$  and mass,  $m$ .*

[1 markah / 1 mark]

- (iii) Kirakan kecerunan graf .

*Calculate the gradient of the graph.*

[2 markah / 2 marks]

**BAB 2 : DAYA DAN GERAKAN I / CHAPTER 2 : FORCE AND MOTION I**

**BAHAGIAN A / SECTION A**

- 1 Rajah 1.1 menunjukkan sehelai pelepah burung dan sebiji bola plastik dilepaskan dari ketinggian yang sama

*Diagram 1.1 shows a feather and a plastic ball release from the same height.*



Rajah 1.1

*Diagram 1.1*

Graf halaju melawan masa untuk kedua-dua objek tersebut adalah seperti Rajah 1.2.

*The velocity-time graph for the two objects is shown in Diagram 1.2.*

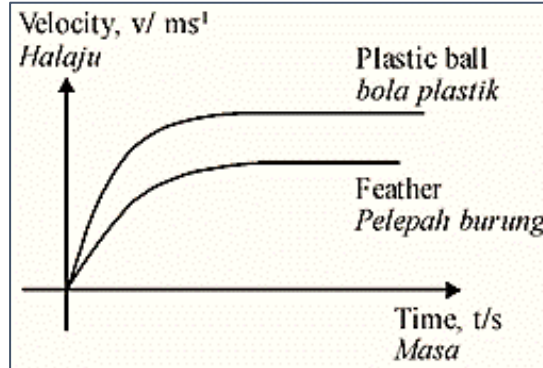

Rajah 1.2

*Diagram 1.2*

- (a) Namakan dua daya yang bertindak ke atas pelepah burung dan bola plastik itu.  
*Name two forces acting on the feather and the plastic ball.*

.....

.....

[2 markah / 2 marks]

(b) Menggunakan graf dalam rajah 1.2 :

*Using the graph in diagram 1.2 :*

(i) Jelaskan pergerakan kedua-dua objek.

*Explain the motion of both objects.*

.....

[1 markah / 1 mark]

(ii) Nyatakan objek yang akan sampai dahulu ke tanah.

*State which object will reach the ground first.*

.....

[1 markah / 1 mark]

(c) Jelaskan jawapan anda di (b)(ii).

*Explain your answer in (b)(ii).*

.....

[1 markah / 1 mark]

(d) Pelelah burung dan bola plastik dilepaskan di dalam vakum. Bandingkan pergerakan kedua-dua objek tersebut.

*The feather and the plastic ball are now dropped in a vacuum. Compare the motion of the two objects.*

.....

[1 markah / 1 mark]

- 2 Rajah 2.1 menunjukkan satu pita detik yang dihasilkan apabila sebuah troli bergerak menuruni landasan condong.

*Diagram 2.1 shows a ticker tape produced when a trolley move along an inclined runway.*

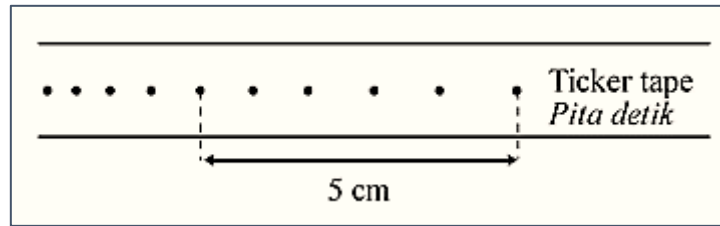

Rajah 2.1

*Diagram 2.1*

- (a) Lengkapkan ayat di bawah dengan menanda (✓) dalam kotak yang betul.  
*Complete the sentence below by ticking (✓) in the correct box.*

Jenis arus yang digunakan oleh jangka masa detik

*The type of current used for ticker timer.*

arus ulang alik   
alternating current

arus terus   
direct current

[1 markah / 1 mark]

- (b) Pada rajah di atas tandakan 'X' untuk menunjukkan **satu detik**.  
*On the diagram above, mark 'X' to show **one tick**.*

[1 markah / 1 mark]

- (c) Berdasarkan rajah di atas tentukan halaju troli itu?  
*Based on diagram above determine the velocity of the trolley?*

[2 markah / 2 marks]

- 3 Rajah 3 di bawah menunjukkan belon udara panas terapung dalam udara.  
*Diagram 3 below shows a hot air balloon floating at rest in the sky.*

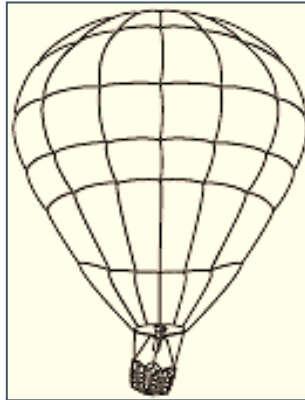

Rajah 3  
*Diagram 3*

- (a) Nyatakan hubungan antara daya apung dengan berat.

*State the relationship between the buoyant force with weight.*

.....

[1 markah / 1 mark]

- (b) Jika isi padu udara yang tersesar ialah  $800 \text{ m}^3$  dan ketumpatan udara ialah  $1.25 \text{ kg m}^{-3}$ , apakah jisim belon itu?

*If the volume of the displaced air is  $800 \text{ m}^3$  and the density of air is  $1.25 \text{ kg m}^{-3}$ , what is the mass of the balloon?*

[ 2 markah / 2 marks]

- (c) Apakah yang harus dibuat untuk merendahkan kedudukan belon udara panas itu?  
*What should be done to lower the hot air balloon?*

.....

[1 markah / 1 mark]

## BAHAGIAN B DAN C / SECTION B AND C

- 1 Sebagai seorang penyelidik, anda telah ditugaskan untuk mengkaji ciri-ciri kereta untuk diubahsuai kepada kereta lumba.

*As a researcher, you are asked to investigate the characteristics of a car to be modified into a racing car.*

- (a) Apakah yang dimaksudkan dengan halaju?

*What is meant by velocity?*

[1 markah / 1 mark]

- (b) Sebuah kereta yang sedang bergerak dengan halaju seragam tiba-tiba diberhentikan apabila pemandu memperhatikan isyarat kecemasan untuk berhenti. Lakarkan graf halaju-masa untuk menggambarkan gerakan tersebut. Seterusnya terangkan perubahan yang berlaku dan tunjukkan bagaimana jarak membrek ditentukan.

*A car moving with uniform velocity is brought to a stop when the driver sees an emergency signal for stopping.*

*Sketch a velocity-time graph for the motion of the car and explain the changes that occur and show how the braking distance is determined.*

[5 markah / 5 marks]

- (c) Sebaik sahaja mendarat, halaju sebuah kapal terbang ialah  $50.0 \text{ ms}^{-1}$ . Jika nyahpecutan kapal terbang itu ialah  $3.0 \text{ m s}^{-2}$ , berapakah panjang minimum landasan yang diperlukan oleh kapal terbang itu untuk berhenti?

*When an airplane is landing, its velocity is  $50.0 \text{ ms}^{-1}$ . If the deceleration of the airplane is  $3.0 \text{ m s}^{-2}$ , what is the minimum length of the runway needed by the airplane to stop?*

[4 markah / 4 marks]

2 Rajah 4.1 menunjukkan seorang budak lelaki berjisim 60 kg berdiri di dalam sebuah bot pegun yang berjisim 50 kg.

Rajah 4.2 menunjukkan bot itu bergerak menjauhi jeti dengan halaju  $6 \text{ ms}^{-1}$  apabila budak lelaki itu melompat ke jeti dengan halaju  $5 \text{ ms}^{-1}$ .

*Diagram 4.1 shows a boy of mass 60 kg standing in a stationary boat of mass 50 kg.*

*Diagram 4.2 shows the boat moving away from the jetty with velocity of  $6 \text{ ms}^{-1}$  when the boy jumped to the jetty with velocity of  $5 \text{ ms}^{-1}$ .*

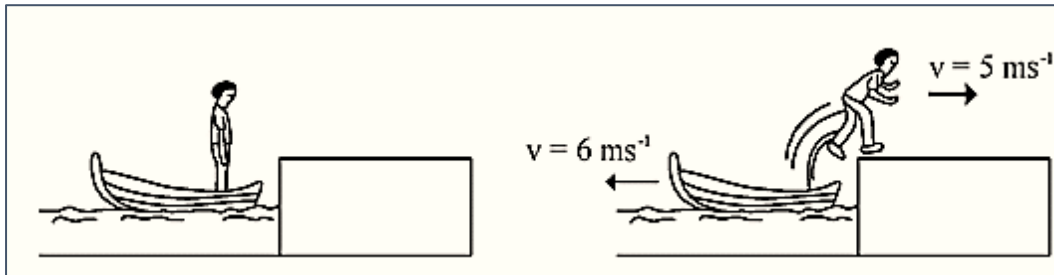

Rajah 4.1  
Diagram 4.1

Rajah 4.2  
Diagram 4.2

(a) Apakah maksud dengan momentum?

*What is the meaning of momentum?*

[1 markah / 1 mark]

(b) Terangkan, dalam sebutan momentum, rejangan sebuah enjin roket.

*Describe, in terms of momentum, the propulsion of a rocket engine.*

[4 markah / 4 marks]

## BAB 3 : KEGRAVITIAN / CHAPTER 3 : GRAVITATION

### BAHAGIAN A / SECTION A

1

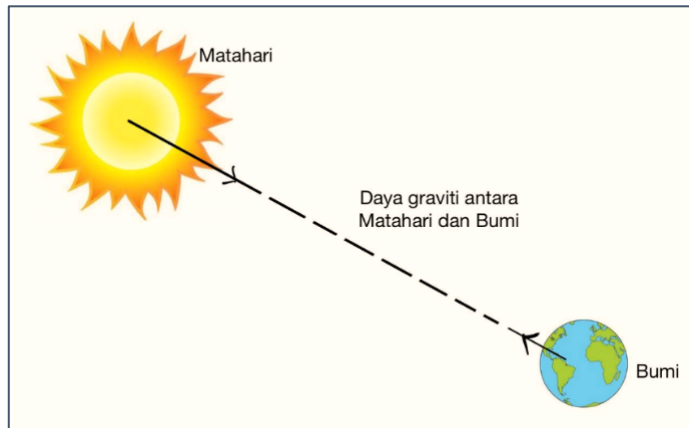

Rajah 1 / Diagram 1

Rajah 1 menunjukkan daya graviti antara Matahari dan Bumi.

*Diagram 1 shows the gravitational force between the Sun and the Earth.*

- (a) Nyatakan Hukum Kegravitian Semesta Newton.  
*State Newton's Universal Law of Gravitation.*

---

---

[1 markah / 1 mark]

- (b) Daya gravity antara dua jasad boleh di cari menggunakan persamaan,  
*The force of gravity between two objects can be calculated using the equation,*

$$F = \frac{Gm_1m_2}{r^2}$$

Berdasarkan persamaan di atas, nyatakan apa yang diwakili oleh  
*Based on the above equation, state what is represented by*

(i)  $G$  :

---

[1 markah / 1 mark]

(ii)  $r$  :

---

[1 markah / 1 mark]

(c) Pada Rajah 1 di atas tandakan dan labelkan  $r$  yang diwakili persamaan di (b).

*In Diagram 1 above mark and label  $r$  represented in the equation in (b).*

[1 markah / 1 mark]

2 Sir Isaac Newton, seorang ahli Matematik – Fizik telah menulis suatu teori mengenai tarikan graviti di antara jasad berjisim.

*A Physicist and Mathematician, Sir Isaac Newton wrote a theory on the gravitational pull between two bodies of mass.*

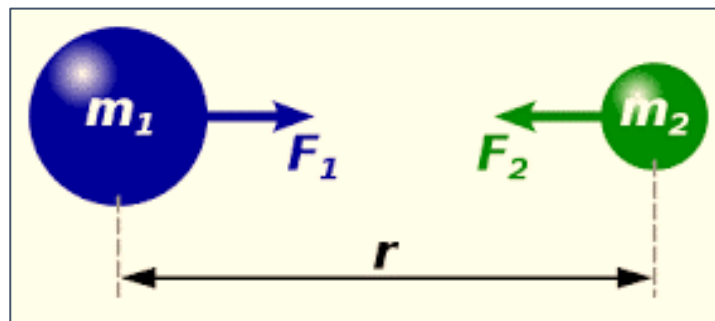

Rajah 2

Diagram 2

(a) Berdasarkan Rajah 2, tuliskan dua hubungan yang melibatkan daya tarikan graviti di antara dua jasad.

*Based on Diagram 2, write two relationships which involve the gravitational pull between two bodies.*

(i)

---

---

(ii)

---

---

[2 markah / 2 marks]

- (b) Rumuskan kedua-dua hubungan yang dinyatakan di (a) bagi menerbitkan formula bagi Hukum Kegravitian Semesta Newton.

*Summarize both of the relation stated in (a) to derive the formula for Newton's Law of Universal Gravitation.*

[3 markah / 3 marks]

3 (a) Takrifkan :

*Define :*

(i) Hukum Kepler Pertama

*Kepler's First Law*

.....  
.....

[1 markah / 1 marks]

(ii) Hukum Kepler Kedua

*Kepler's Second Law*

.....  
.....

[1 markah / 1 marks]

(iii) Hukum Kepler Ketiga

*Kepler's Third Law*

.....  
.....

[1 markah / 1 marks]

(b) Berpandukan Hukum Kegravitian Semesta Newton dan konsep daya memusat, rumuskan dan tunjukkan bahawa kuasa dua halaju suatu planet yang mengorbit Matahari berkadar songsang dengan jejari orbitnya.

*Based on Newton's Law of Universal Gravitation and the centripetal force concept, summarize and show that the square of velocity of a planet orbiting the sun is inversely proportional towards the radius of its orbit.*

[3 markah / 3 marks]

- (c) Terbitkan Hukum Kepler Ketiga,  $T^2 \propto r^3$ , dengan menggunakan persamaan laju linear planet ke dalam persamaan yang diperolehi dalam (b).  
*Derive Kepler's Third Law,  $T^2 \propto r^3$ , using the planet's linear velocity that is obtained in (b).*

[3 markah / 3 marks]

- 4 Jadual 4 di bawah menunjukkan jisim dan jejari bagi Planet Marikh dan Bulan.  
*Table 4 below shows the masses and radius of the Planets Mars and the Moon.*

	JISIM	JEJARI
MARIKH	$6.42 \times 10^{23} \text{ kg}$	$3.4 \times 10^6 \text{ m}$
BULAN	$7.35 \times 10^{22} \text{ kg}$	$1.74 \times 10^6 \text{ m}$ .

Jadual 4  
*Table 4*

- (a) Nyatakan maksud bagi halaju lepas.  
*State the meaning of escape velocity.*

.....  
 .....

[1 markah / 1 marks]

- (b) Berdasarkan data yang diberikan,  
*Based on the data provided,*

- (i) Hitung halaju lepas dari permukaan Marikh.  
*Calculate the escape velocity from the surface of Mars.*

[2 markah / 2 marks]

- (ii) Hitung halaju lepas dari permukaan bulan.  
*Calculate the escape velocity from the surface of the moon.*

[2 markah / 2 marks]

- (c) Halaju lepas bagi suatu objek bergantung kepada :  
*Escape velocity of an object depends on :*

.....

[2 markah / 2 marks]

- Halaju lepas tidak bergantung kepada :  
*Escape velocity does not depends on :*

.....

[1 markah / 1 marks]

5

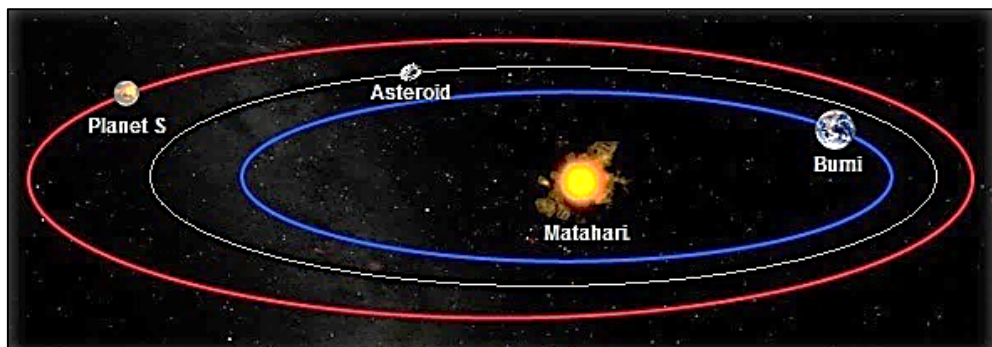

Rajah 5

Diagram 5

Rajah 5 menunjukkan keadaan orbit di angkasa lepas. Diberi jejari orbit bumi adalah  $1.5 \times 10^{11}m$  dan tempoh orbit bumi ialah 1.00 tahun.

*Diagram 5 shows orbital states in outer space. Given the orbital radius for Earth is  $1.5 \times 10^{11}m$  while the orbital period for Earth is 1.00 years.*

- (a) Sekiranya tempoh orbit Planet S ialah 686 hari, tentukan jejari orbit bagi Planet S.  
*If the orbital period for Planet S is 686 days, define the orbital radius for Planet S.*

[3 markah / 3 marks]

- (b) Sebuah asteroid dilihat sedang mengorbit dengan jejari orbit  $1.90 \times 10^{11}$  m .  
Tentukan tempoh orbit bagi asteroid itu.  
*An asteroid is seen orbiting with the orbital radius of  $1.90 \times 10^{11}$  m. Define the orbital period for this asteroid.*

[3 markah / 3 marks]

- 6 Rajah 6 menunjukkan kedudukan dua planet Bumi dan Marikh bergerak dalam orbit membulat mengelilingi Matahari.  
*Diagram 6 shows the positions of the two planets Earth and Mars moving in a circular orbit around the Sun.*

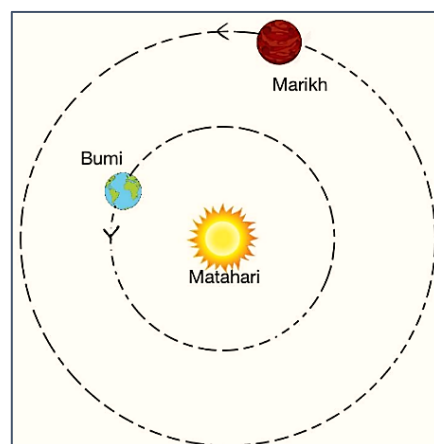

Rajah 6  
*Diagram 6*

- (a) (i) Pertimbangkan daya yang bertindak ke atas Bumi yang bergerak dalam orbit membulat berjejari,  $r$  dengan tempoh,  $T$  mengelilingi Matahari. Terbitkan satu persamaan menghubungkan tempoh,  $T$  dengan jejari,  $r$ .  
*Consider a force acting on the Earth moving in a circular orbit of radius,  $r$  with period,  $T$  around the Sun. Derive an equation relating the period,  $T$  to the radius,  $r$ .*

[4 markah / 4 marks]

- (ii) Namakan hukum yang terlibat dalam hubungan di (a)(i).  
*Name the law involved in the relation in (a) (i).*

.....

[1 markah / 1 marks]

- (b) Bumi bergerak dengan tempoh  $3.15 \times 10^7$  s pada jarak purata  $1.50 \times 10^{11}$  m dari Matahari.

*The Earth moves with a period of  $3.15 \times 10^7$  s at an average distance of  $1.50 \times 10^{11}$  m from the Sun..*

- (i) Hitung tempoh Musytari mengelilingi Matahari pada jarak purata  $7.79 \times 10^{11}$  m dari Matahari.  
*Calculate the period of Jupiter orbiting the Sun at an average distance of  $7.79 \times 10^{11}$  m from the Sun*

[3 markah / 3 marks]

- (ii) Hitung jisim Matahari.  
*Calculate the mass of the Sun.*

[4 markah / 4 marks]

## BAHAGIAN B DAN C / SECTION B AND C

- 1 (a) (i) Nyatakan maksud halaju lepas.  
*State the meaning of escape velocity.*  
[1 markah / 1 mark]
- (ii) Nyatakan dua faktor yang menentukan laju linear satelit-satelit yang mengorbit Bumi.  
*State two factors that determine the linear speed of satellites orbiting the Earth.*  
[2 markah / 2 marks]
- (b) (i) Nyatakan perbezaan satelit geopegun dan satelit bukan geopegun dari aspek arah gerakan, tempoh orbit, perubahan kedudukan pada orbit, dan fungsi.  
*State the differences between geostationary and non - geostationary satellites in terms of direction of motion, orbital period, change of position in orbit, and function.*  
[8 markah / 8 marks]
- (ii) Nyatakan empat persamaan satelit geopegun dan satelit bukan geopegun.  
*State four similarities of geostationary satellites and non - geostationary satellites.*  
[4 markah / 4 marks]
- (iii) Apakah yang akan terjadi kepada satelit apabila laju linearnya berkurang? Berikan satu sebab bagi jawapan anda.  
*What will happen to the satellite when its linear speed decreases? Give a reason for your answer.*  
[2 markah / 2 marks]
- (c) Beri dua kesan terhadap manusia jika berada di kawasan graviti sifar.  
*Give two effects on humans if they are in the region of zero gravity.*  
[2 markah / 2 marks]

- 2 (a) Terangkan Hukum Kegravitian Semesta Newton.

*Explain Newton's Law of Universal Gravitation.*

[1 markah / 1 marks]

- (b) Terbitkan rumus pecutan graviti dengan menggunakan pengetahuan tentang Hukum Kegravitian Semesta Newton dan Hukum Gerakan Newton Kedua.

*Derive the formula for the acceleration of gravity using knowledge of Newton's Law of Universal of Gravitation and Newton's Second Law of Motion.*

[4 markah / 4 marks]

- (c) Nyatakan lima kesan graviti rendah terhadap tumbesaran manusia dan lima kesan graviti tinggi terhadap tumbesaran manusia.

*State five effects of low gravity on human growth and five effects of high gravity on human growth.*

[10 markah / 10 marks]

- (d) (i) Nyatakan rumus yang digunakan untuk menentukan jisim Bumi dan Matahari.

*State the formula used to determine the mass of the Earth and the Sun.*

[1 markah / 1 marks]

- (ii) Nyatakan dua maklumat yang diperlukan untuk menentukan jisim Bumi.

*State two information required to determine the mass of the Earth.*

[2 markah / 2 marks]

- (iii) Nyatakan dua maklumat yang diperlukan untuk menentukan jisim Matahari.

*State two information required to determine the mass of the Sun.*

[2 markah / 2 marks]

- 3 (a) Nyatakan maksud halaju lepas.  
*State the meaning of escape velocity.*

[1 markah / 1 marks]

- (b) Matahari merupakan jasad yang terbesar dalam sistem suria dengan jisim  $1.99 \times 10^{30}$  kg dan jejari  $6.96 \times 10^8$  m. Bumi adalah planet ketiga terdekat dengan matahari yang mengorbit mengelilinginya dengan jisim  $5.97 \times 10^{24}$  kg dan jejari  $6.37 \times 10^6$  m. Bulan yang mengorbit mengelilingi Bumi mempunyai jisim  $7.35 \times 10^{22}$  kg dan jejari  $1.74 \times 10^6$  m.

*The sun is the largest body in the solar system by mass  $1.99 \times 10^{30}$  kg and a radius of  $6.96 \times 10^8$  m. Earth is the third closest planet to the sun orbiting around it with a mass of  $5.97 \times 10^{24}$  kg and a radius of  $6.37 \times 10^6$  m. The moon orbiting the Earth has mass  $7.35 \times 10^{22}$  kg and a radius of  $1.74 \times 10^6$  m.*

Berdasarkan maklumat yang diberi, hitung dan bandingkan,  
*Based on the information given, calculate and compare,*

- (i) Pecutan graviti di permukaan Matahari, Bumi dan Bulan.

*Gravitational acceleration on the surface of the Sun, Earth and Moon.*

[7 markah / 7 marks]

- (ii) Halaju lepas dari permukaan Matahari, Bumi dan Bulan.

*Escape velocity from the surface of the Sun, Earth and Moon.*

[7 markah / 7 marks]

- (c) Halaju lepas dari permukaan planet Marikh ialah  $5.02 \text{ km s}^{-1}$ . Anggapkan bahawa jisim planet Marikh ialah  $M$  dan jejarynya ialah  $R$ . Berapakah halaju lepas sebuah kapal angkasa pada altitude  $0.5R$  daripada permukaan planet Marikh?

*The escape velocity on the surface of the planet Mars is  $5.02 \text{ km s}^{-1}$ . Assume that the mass of the planet Mars is  $M$  and its radius is  $R$ . What is the escape velocity of a spacecraft at an altitude of  $0.5R$  from the surface of the planet Mars?*

[5 markah / 5 marks]

## BAB 4 : HABA / CHAPTER 4 : HEAT

### BAHAGIAN A / SECTION A

- 1 Rajah 1 menunjukkan satu fenomena semulajadi yang berlaku di tepi pantai pada siang hari. Darat dan laut mempunyai muatan haba tentu yang berbeza.

*Diagram 1 shows a natural phenomenon occurring during the day at the seashore. Land and sea have different specific heat capacity.*

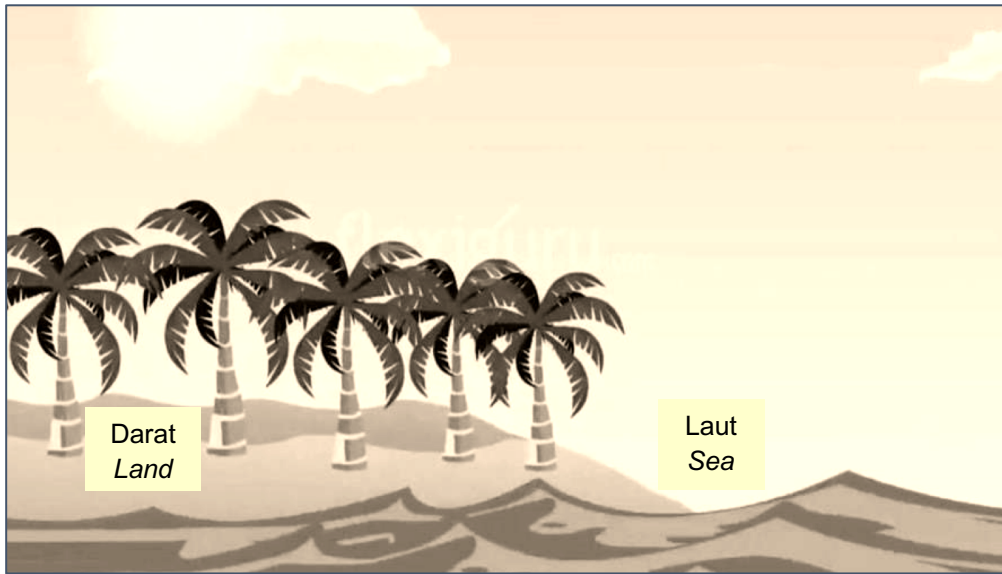

Rajah 1

Diagram 1

- (a) Apakah yang dimaksudkan dengan muatan haba tentu?

*What is the meaning of specific heat capacity?*

.....

.....

[1 markah / 1 mark]

- (b) Pada Rajah 1, lukiskan peredaran udara yang berlaku dan namakan fenomena tersebut.

*In Diagram 1, draw the air circulation and name the phenomenon.*

.....

[2 markah / 2 marks]

- (c) Hitungkan nilai muatan haba tentu untuk 10 000 liter air laut sekiranya kenaikan suhu ialah  $0.00256^{\circ}\text{C}$  dan haba yang dikenakan adalah sebanyak 100 000 J. (1000 liter : 1000 kg)  
*Calculate the specific heat capacity of 10 000 litre of sea water if the rise in temperature is  $0.00256^{\circ}\text{C}$  and heat supplied is 100 000 J. (1000 litre : 1000 kg)*

[2 markah / 2 marks]

- (d) Gariskan jawapan yang betul dalam kurungan untuk melengkapkan ayat di bawah.  
*Underline the correct answer in the bracket to complete the sentence below*

Merujuk kepada jawapan 1(b), angin bertiup lebih laju di waktu (pagi yang sejuk / tengahari yang panas).

*Referring to the answer in 1(b), the wind blows the fastest during the (cold morning / hot afternoon).*

[1 markah / 1 mark]

- 2 Rajah 2 menunjukkan gelembung-gelembung udara dihasilkan oleh pam udara di dalam sebuah akuarium berisi air tawar.

*Diagram 2 shows air bubbles produced by an air pump in an aquarium filled with fresh water.*

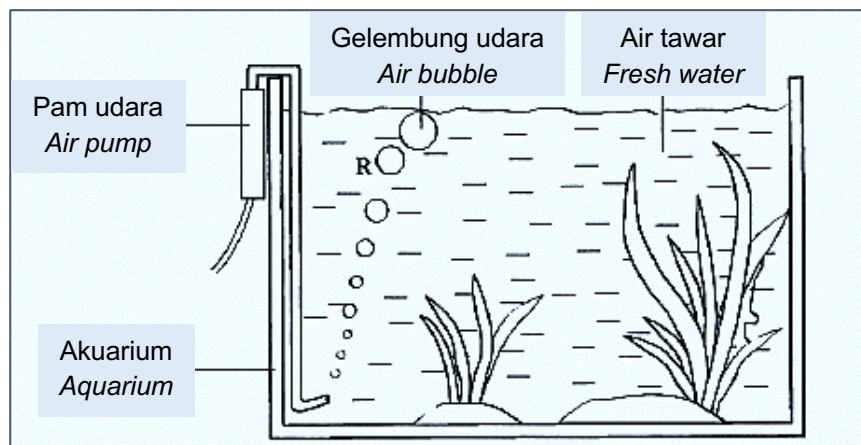

Rajah 2

*Diagram 2*

- (a) Terangkan mengapa isipadu gelembung udara bertambah apabila bergerak menghampiri permukaan.

*Explain why the volume of an air bubble increases as it moves towards the surface.*

.....

[1 markah / 1 mark]

- (b) Namakan hukum fizik yang terlibat di 2(a).

*Name the physics law state involved in 2(a)*

.....

[1 markah / 1 mark]

- (c) Apakah perubahan dalam isipadu gelembung udara pada paras R apabila air tawar digantikan dengan air laut yang mempunyai ketumpatan yang lebih tinggi?

*What is the change in the volume of an air bubble at level R when the fresh water is replaced by sea water of higher density?*

.....

[1 markah / 1 mark]

- (d) Satu gelembung udara yang mempunyai isipadu  $5 \text{ cm}^3$  dibebaskan oleh pam udara pada kedalaman 0.5 m. Hitung isipadu gelembung udara itu apabila sampai di permukaan air. [Anggap tekanan atmosfera adalah 10 m air]

*An air bubble of volume  $5 \text{ cm}^3$  is released by an air pump at a depth of 0.5 m. Calculate the volume of the air bubbles when it reaches the surface of the water. [Assume that the atmospheric pressure is 10 m water]*

[3 markah / 3 marks]

- 3 Berpeluh adalah satu cara badan kita mengekalkan suhu badan. Sebahagian besar peluh adalah air dan ianya dikeluarkan oleh kelenjar peluh seperti yang ditunjukkan dalam Rajah 3.

*Sweating is one of the ways our body maintains of the body temperature. Sweat is largely made up of water and it comes from sweat glands as shown in the Diagram 3.*

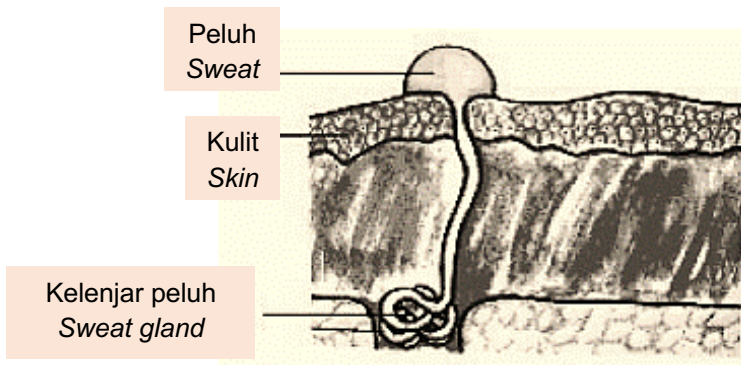

Rajah 3  
Diagram 3

- (a) Apakah perubahan jirim yang berlaku semasa berpeluh?  
*What is the changes state of matter when we sweating?*

.....  
[1 markah / 1 mark]

- (b) Menggunakan teori kinetik jirim, terangkan bagaimana proses penyejatan mengeluarkan haba dari badan kita.  
*Using kinetic theory of matter, explain how evaporation takes away heat from our body.*

.....  
.....  
[2 markah / 2 marks]

- (c) Apakah konsep fizik yang terlibat semasa proses penyejatan?  
*What is the physics concept involved in evaporation?*

.....  
[1 markah / 1 mark]

- (d) Semasa bermain badminton, 0.05 kg peluh tersejat dari badan Ahmad. Hitungkan kuantiti haba yang hilang dari badan Ahmad yang disebabkan oleh penyejatan peluh itu. Haba pendam tentu pengewapan peluh ialah  $2.3 \times 10^6 \text{ J kg}^{-1}$

*While playing badminton, 0.05 kg of sweat evaporated from Ahmad's body. Calculate the quantity of heat lost from his body due to the evaporation. The latent heat of vaporization of sweat is  $2.3 \times 10^6 \text{ J kg}^{-1}$*

[2 markah / 2 marks]

### BAHAGIAN B DAN C / SECTION B AND C

- 1 Rajah 1.1 menunjukkan satu sudu keluli nirkarat di dalam secawan kopi panas.

*Diagram 1.1 shows a stainless-steel spoon in a cup of hot tea*

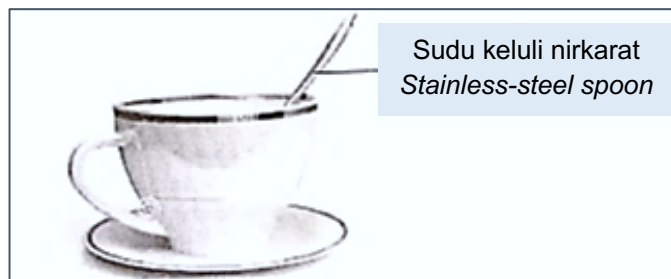

Rajah 1.1

*Diagram 1.1*

- (a) Apakah yang dimaksudkan dengan keseimbangan terma?

*What is the meaning of thermal equilibrium?*

[1 markah / 1 mark]

- (b) Berpandukan kepada konsep keseimbangan terma, terangkan bagaimana sudu keluli nirkarat itu menjadi panas sama seperti kopi di dalam cawan tersebut.

*Based on the concept of thermal equilibrium, explain how the stainless-steel spoon becomes as hot as the coffee in the cup.*

[4 markah / 4 marks]

- (c) Suatu bahan dalam keadaan pepejal berjisim 0.03 kg dipanaskan dengan menggunakan pemanas rendam 240 V, 0.4 kW. Rajah 1.2 menunjukkan keluk pemanasan bagi pepejal tersebut

*A solid substance, of mass 0.03 kg, is heated using an immersion heater of 240 V, 0.4 kW. Diagram 1.2 shows the heating curve of the solid.*

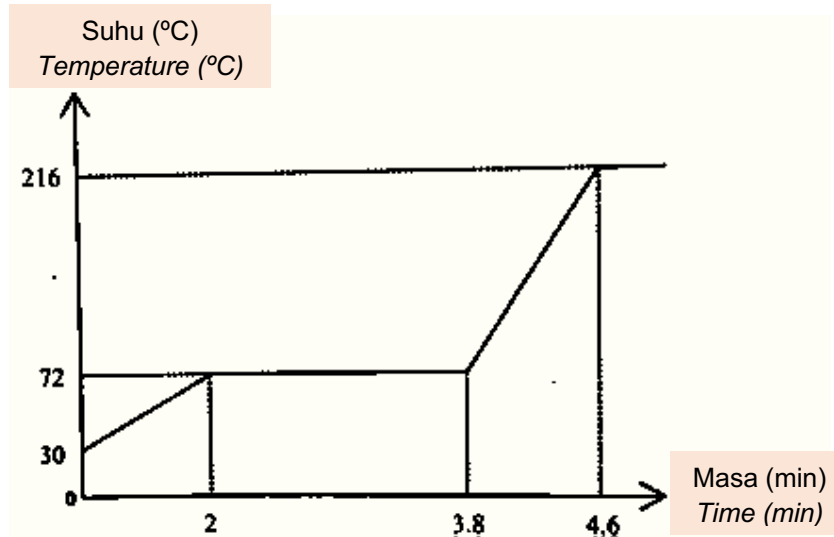

Rajah 1.2  
Diagram 1.2

Hitung

- (i) Haba pendam tentu pelakuran bahan itu.  
*The specific latent heat of fusion of the substance.*
- (ii) Muatan haba tentu bahan itu dalam keadaan cecair  
*The specific heat capacity of the substances in liquid state*

[5 markah / 5 marks]

- 2 Rajah 2 menunjukkan ikan Angler yang hanya hidup di dasar laut.  
*Diagram 2 shows an Anglerfish, a type of fish that lives only in deep sea.*



Rajah 2  
Diagram 2

Apabila ia dibawa ke permukaan air laut, ikan tersebut akan mati. Dengan menggunakan konsep Fizik yang sesuai, terangkan mengapa ikan tersebut mati.

*When it is brought to the surface of the seawater, the fish will die. By using physics concept, explain why the fish dies.*

[4 markah / 4 marks]

- 3 Tekanan gas dalam sebuah silinder gas memasak adalah 150 MPa pada suhu 27°C. Kebakaran kecil berdekatan yang telah berlaku mengakibatkan suhu gas itu meningkat kepada 155 °C.

*The pressure of the gas in a cylinder of cooking gas is 150 MPa at a temperature 27°C. A small fire nearby causes the temperature of the gas increases to 155 °C.*

- (i) Hitung tekanan akhir gas itu.

*Calculate the final pressure of the gas.*

- (ii) Jisim gas dalam tong gas silinder ialah 14 kg. Hitungkan nilai muatan haba tentu gas sekiranya ia menerima 2000 J haba semasa kebakaran.

*The mass of gas inside the cylinder is 14 kg. Calculate the specific heat capacity of the gas if it receives 2000 J of heat during the fire.*

[4 markah / 4 marks]

- 4 Terangkan mengapa periuk memasak diperbuat daripada konduktor haba yang baik sementara pemegangnya diperbuat daripada konduktor haba yang lemah.

*Explain why the body of a cooking pot is made of good heat conductor whereas the handle of the pot is made of poor heat conductor.*

[4 markah / 4 marks]

- 5 Terangkan bagaimana kapsul angkasa boleh bertahan pada suhu yang tinggi.

*Explain how space capsule can withstand high temperature.*

[4 markah / 4 marks]

# BAB 5 : GELOMBANG / CHAPTER 5 : WAVES

## BAHAGIAN A / SECTION A

- 1 Rajah 1 di bawah menunjukkan corak bagi gelombang air apabila gelombang air merambat dari laut ke pantai.

*Diagram 1 below shows the pattern of the water wave when the water waves propagated from the sea to the beach.*

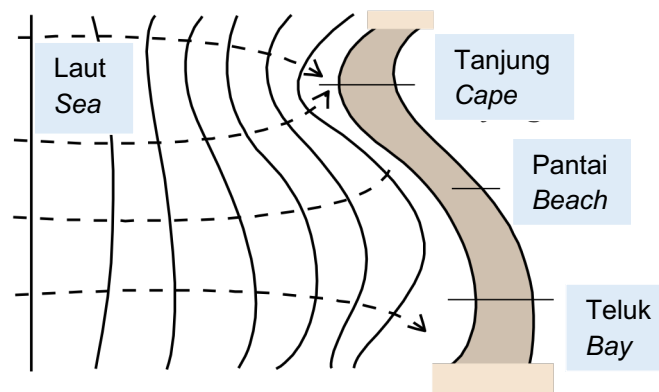

Rajah 1  
Diagram 1

- (a) Namakan fenomena yang terlibat dalam pemerhatian di atas.  
*Name the phenomenon that involved in the above observation.*

.....

[1 markah / 1 mark]

- (b) Mengapakah gelombang air mengikut bentuk pantai apabila ia merambat dari laut ke pantai?  
*Why do the water waves follow the shape of the beach when its propagated from the sea to the beach?*

.....

[1 markah / 1 mark]

- (c) Apakah kuantiti fizik yang akan berkurang apabila gelombang air merambat dari laut ke pantai?

*What physical quantity will decrease when the water waves propagated from the sea to the beach?*

.....

[1 markah / 1 mark]

- (d) Gelombang air dengan panjang gelombang 1.2 m bergerak dengan halaju 2.5 m s<sup>-1</sup> dari laut ke pantai. Halaju gelombang apabila menghampiri pantai ialah 1.8 m s<sup>-1</sup>. Kira frekuensi gelombang air itu.

*The water waves with a wavelength of 1.2 m travels with velocity 2.5 m s<sup>-1</sup> from the sea to the beach. The velocity of the waves when reaching the beach is 1.8 m s<sup>-1</sup>. Find the frequency of the water wave*

[2 markah / 2 marks]

- 2 Jadual 2 menunjukkan empat jenis gelombang elektromagnet.

*Table 2 shows four types of electromagnetic waves.*

<b>JENIS GELOMBANG ELEKTROMAGNET</b> <b>TYPES OF ELECTROMAGNETIC WAVES</b>
Sinar -X / X-rays
Cahaya tampak / Visible light
Gelombang mikro / Microwaves
Infra-merah / Infra-red

Jadual 2 / Table 2

- (a) Susun gelombang elektromagnet mengikut tertib panjang gelombang meningkat.  
*Arrange the electromagnetic waves in the order of increasing wavelength.*

.....

[1 markah / 1 mark]

- (b) Dari jadual di atas, namakan dua jenis gelombang yang berasal dari matahari.  
*From the table above, name two types of waves that originate from the sun.*

.....

[1 markah / 1 mark]

- (c) Nyatakan satu kegunaan gelombang mikro.  
*State one use of microwave.*

.....

[1 markah / 1 mark]

- (d) Jika panjang gelombang bagi gelombang mikro ialah  $5.0 \times 10^{-2}$  m, hitungkan frekuensinya, diberi laju cahaya dalam vakum ialah  $3.0 \times 10^8$  ms<sup>-1</sup>.  
*If the wavelength of microwave is  $5.0 \times 10^{-2}$  m, calculate its frequency, given that the speed of light in vacuum is  $3.0 \times 10^8$  ms<sup>-1</sup>.*

[2 markah / 2 marks]

- 3 Rajah 3 di bawah menunjukkan gelombang air sedang bergerak menuju satu penghalang kecil P di tengah sebuah kolam. Jarak antara 6 muka gelombang berturutan ialah 2 m.  
*Diagram 3 below shows water waves moving towards a small obstacle P at the middle of a pond. The distance between six consecutive wavefronts is 2 m.*

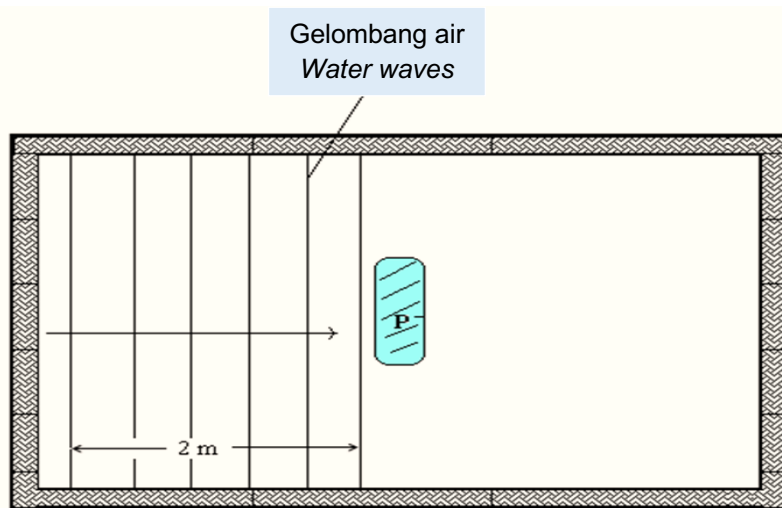

Rajah 3

Diagram 3

- (a) Namakan fenomena gelombang berlaku apabila gelombang air melalui penghalang itu.  
*Name the wave phenomenon involved when water waves passing through the obstacle.*

.....  
 [1 markah / 1 mark]

- (b) Terangkan apakah yang terjadi kepada amplitud gelombang air selepas melalui penghalang?  
*Explain what happen to the amplitude of water waves after passing through the obstacle?*

.....  
 [2 markah / 2 marks]

- (c) Frekuensi gelombang air ialah 5 Hz. Hitungkan laju gelombang.  
*The frequency of the water waves is 5 Hz. Calculate the speed of the waves.*

.....  
 [2 markah / 2 marks]

## BAHAGIAN B DAN C / SECTION B AND C

- 1 Rajah 1 menunjukkan corak interferens daripada dua punca yang koheran dengan dua pencelup  $S_1$  dan  $S_2$  dalam tangki riak. Garisan bulatan mewakili garisan puncak atau muka gelombang. *Diagram 1 shows the interference pattern from two coherent sources formed by two spherical dippers,  $S_1$  and  $S_2$  in a ripple tank. Each of the circular line represents a crest - line or the wave front.*

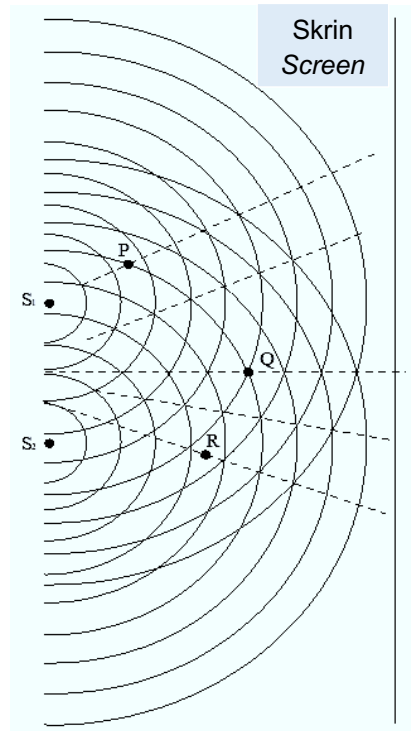

Rajah 1  
Diagram 1

- (a) Apa yang dimaksudkan dengan dua punca yang koheran?  
*What is meant by two coherent sources?*
- [1 markah / 1 mark]
- (b) Bagaimanakan anda memastikan dua punca adalah koheran?  
*How can you ensure that the two sources are coherent?*
- [1 markah / 1 mark]
- (c) Huraikan jenis interferens pada  
*Describe the type of interference at*
- (i) P [1 markah / 1 mark]
- (ii) Q [1 markah / 1 mark]
- (iii) R [1 markah / 1 mark]

2 Rajah 2 menunjukkan ombak sedang bergerak menuju ke sebuah pelabuhan.

Diagram 2 shows waves moving towards a harbour.

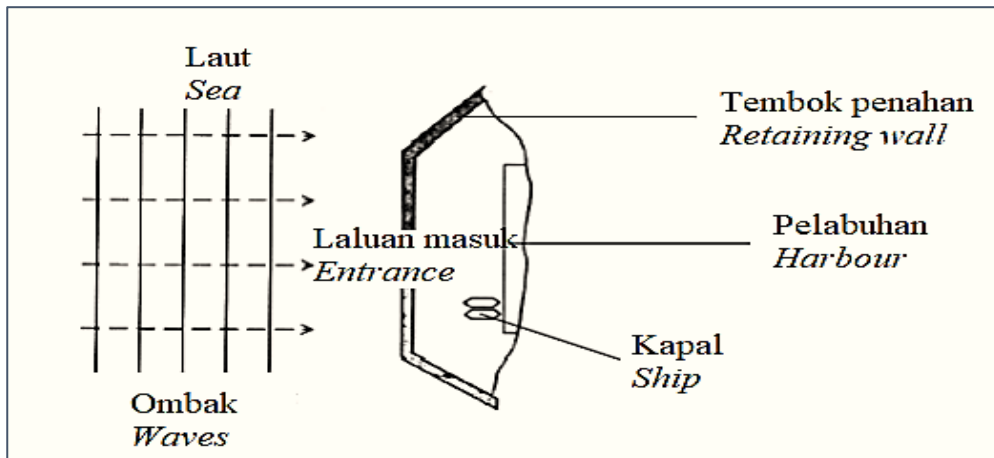

Rajah 2

Diagram 2

(a) (i) Apakah maksud pembelauan?  
*What is the meaning of diffraction?* [1 markah / 1 mark]

(ii) Lukis corak gelombang bagi ombak itu selepas melalui laluan masuk pelabuhan itu.  
*Draw the wave pattern of the waves after passing through the entrance of the harbour.* [2 markah / 2 marks]

(b) Laluan masuk itu dijadikan lebih lebar untuk membenarkan lebih banyak kapal memasuki pelabuhan.

*The entrance is made wider to allow more ships to enter the harbour.*

Apakah kesan terhadap

*What is the effect on*

(i) Gelombang yang melalui laluan masuk itu?  
*The waves passing through the entrance?* [1 markah / 1 mark]

(ii) Pelabuhan itu?  
*The harbour?* [1 markah / 1 mark]

- 3 Rajah 3 menunjukkan corak gelombang yang dihasilkan di dalam sebuah tangki riak oleh getaran dua penggetar.

*Diagram 3 shows the wave pattern produced in a ripple tank by the vibration of two dippers.*

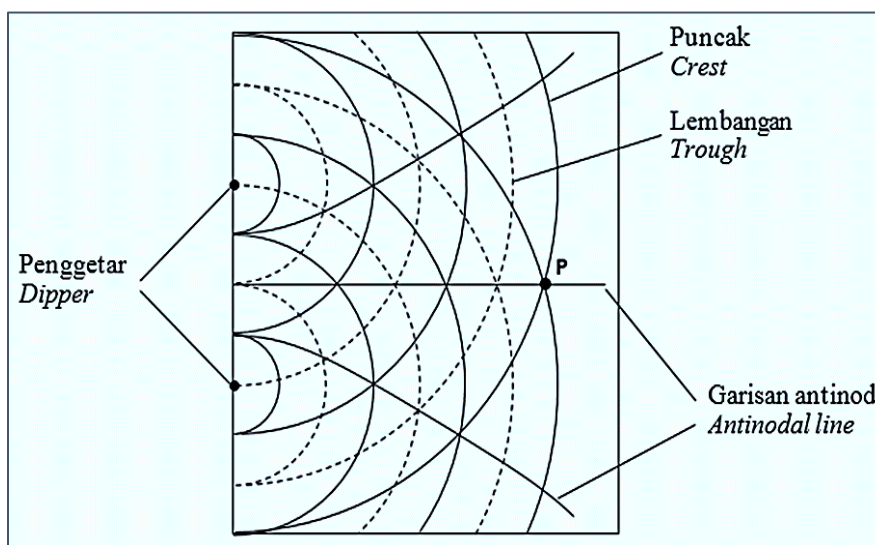

Rajah 3

Diagram 3

- (a) Apakah fenomena gelombang yang menghasilkan corak gelombang dalam Rajah 3?

*What is the wave phenomenon that produced the wave pattern in Diagram 3?*

[1 markah / 1 mark]

- (b) Apakah yang akan berlaku kepada jarak antara dua garis antinod yang berturutan apabila jarak antara penggetar dikurangkan?

*What will happen to the distance between two consecutive antinodal lines when the distance between the dippers is decreased?*

[1 markah / 1 mark]

- (c) (i) Seketul gabus yang kecil diletakkan di titik P. Nyatakan pergerakan gabus tersebut.

*A small piece of cork is placed at point P. State the motion of the cork.*

[1 markah / 1 mark]

- (ii) Terangkan jawapan anda dalam 2(c)(i).

*Explain your answer in 2(c)(i).*

[1 markah / 1 mark]

- (d) Kedalaman air ditambah. Apakah yang akan berlaku kepada jarak antara dua garis antinod yang berturutan? Jelaskan jawapan anda.

*The depth of water is increased. What happens to the distance between two consecutive antinodal lines? Explain your answer.*

[3 markah / 3 marks]

- 4 Rajah 4 menunjukkan satu pengubahsuaian kepada pelabuhan untuk mengatasi masalah laluan kapal-kapal yang bertambah. Corak gelombang yang dihasilkan di laluan masuk adalah seperti ditunjukkan dalam Rajah 4.

*Diagram 4 shows a modification to the harbour to overcome the heavy sea traffic problem.*

*The wave pattern produced at the entrances is shown in Diagram 4.*

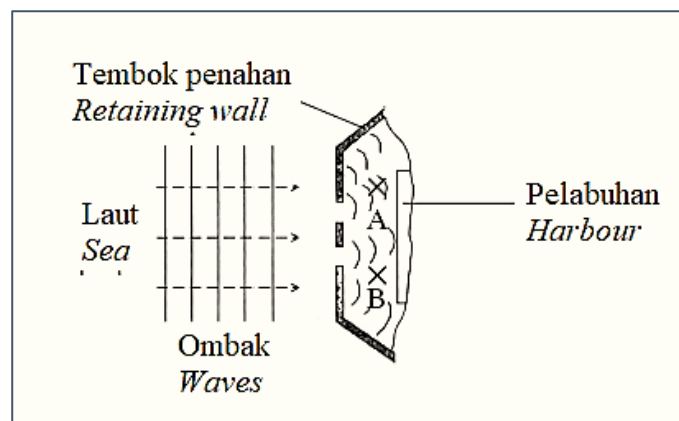

Rajah 4

Diagram 4

- (a) Corak gelombang yang terbentuk adalah disebabkan oleh superposisi gelombang gelombang dari dua sumber yang koheren. Apakah maksud sumber yang koheren?  
*The wave pattern formed is caused by the superposition of waves from two coherent sources. What is the meaning of coherent sources?*

[1 markah / 1 mark]

- (b) Huraikan gerakan dua buah kapal yang serupa yang berada di A dan B.  
Terangkan jawapan anda.

*Describe the movement of two similar ships that are located at A and B.*

*Explain your answer.*

[4 markah / 4 marks]

## BAB 6 : CAHAYA DAN OPTIK / CHAPTER 6 : LIGHT AND OPTICS

### BAHAGIAN A / SECTION A

- 1 Rajah 1 menunjukkan cermin sfera yang biasa digunakan oleh doktor gigi.

*Diagram 1 shows a spherical mirror commonly used by dentist.*



Rajah 1

*Diagram 1*

- (a) Namakan jenis cermin yang ditunjukkan dalam Rajah 1

*Name the type of mirror shown in Diagram 1*

.....

[1 markah / 1 mark]

- (b) Apakah fenomena cahaya yang berlaku di cermin sfera?

*What is the phenomenon of light occurring in the spherical mirror?*

.....

[1 markah / 1 mark]

- (c) Nyatakan ciri-ciri imej yang dibentuk pada cermin.

*State the characteristics of the image formed by the mirror.*

.....

[1 markah / 1 mark]

- (d) Lukis gambar rajah sinar untuk menunjukkan bagaimana imej tersebut terbentuk. *Draw a ray diagram to show how the image is formed.*

[3 markah / 3 marks]

- 2 Rajah 2 menunjukkan satu sinar cahaya ditujukan secara normal ke sisi AB bagi sebuah prisma kaca. Diberi bahawa indeks biasan cahaya bagi prisma itu ialah 1.5

*Diagram 2 shows a light ray which directs normally at the side AB of a glass prism. Given that the refraction index of the prisms is 1.5*

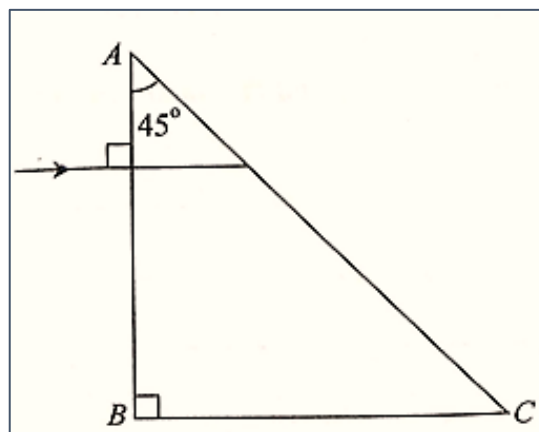

Rajah 2

Diagram 2

- (a) (i) Berapakah sudut tuju bagi sinar pada AB?

*What is the angle of incidence of the ray at AB?*

.....

[1 markah / 1 mark]

- (ii) Berapakah sudut tuju pada AC?

*What is the angle of incidence of the ray at AC?*

.....

[1 markah / 1 mark]

- (iii) Hitungkan sudut genting bagi prisma kaca.  
*Calculate the critical angle of the glass prism.*

[2 markah / 2 marks]

### BAHAGIAN B DAN C / SECTION B AND C

- 1 Rajah 1 menunjukkan seorang pemandu kereta sedang memandu pada suatu hari yang panas terik. Satu lopak air kelihatan di permukaan jalan di hadapannya, tetapi lopak air itu hilang apabila dia menghampirinya.

*Diagram 1 shows a car driver is driving on a hot day. A pool of water is seen on the road surface in front of him, but the pool of water disappears when he approaches it.*

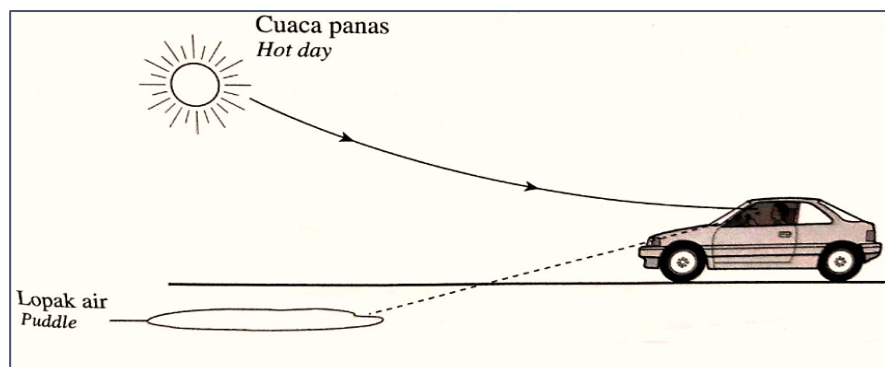

Rajah 1  
*Diagram 1*

- (a) (i) Namakan fenomena di atas.  
*Name the phenomenon above.*
- (ii) Terangkan bagaimana fenomena di 1(a) (i) boleh berlaku.  
*Explain how the phenomenon in 1(a)(i) occurs.*

[1 markah / 1 mark]

[4 markah / 4 marks]

- (b) Sebatang pensel diletakkan pada 25 cm di hadapan sebuah kanta cembung dengan panjang fokus 10 cm.

*A pencil is placed 25 cm in front of a convex lens with focal length of 10 cm.*

- (i) Hitungkan jarak imej dan pembesaran imej.

*Calculate the image distance and the image magnification.*

[4 markah / 4 marks]

- (ii) Nyatakan ciri-ciri imej yang terbentuk.

*State the characteristics of the image formed.*

[1 markah / 1 mark]

- 2 Rajah 2 menunjukkan satu bongkah kaca semi bulatan. Satu sinar cahaya ditujukan secara tegak ke suatu sisi blok kaca itu. Sinar itu kemudiannya memasuki bongkah kaca itu dan menuju ke titik O sebelum keluar semula. Sudut tuju sinar itu di dalam kaca adalah  $30^\circ$ .

*Diagram 2 shows a ray of light directed perpendicularly at a side of the semicircular glass block. The ray passes through the glass block to a point O before leaving the glass block. The angle of incidence in the glass block is  $30^\circ$ .*

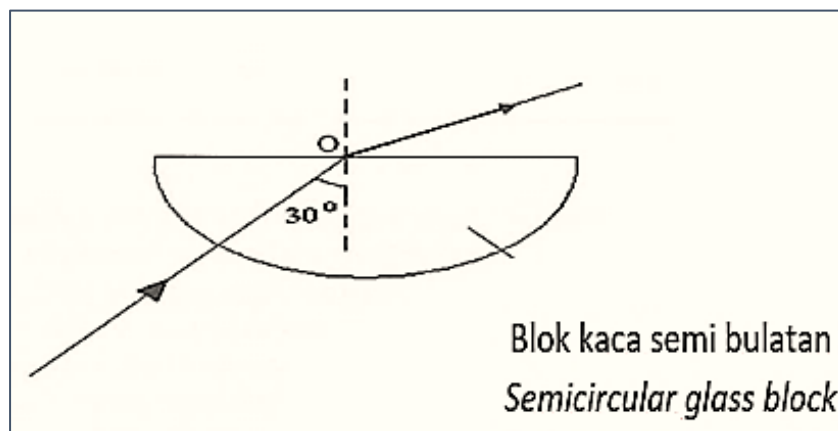

Rajah 2

Diagram 2

- (a) Apakah yang dimaksudkan dengan sudut tuju?

*What is meant by angle of incidence?*

[1 markah / 1 mark]

- (b) Terangkan bagaimana pantulan dalam penuh berlaku dalam Rajah 2.

*Explain how total internal reflection occurs in Diagram 2.*

[4 markah / 4 marks]

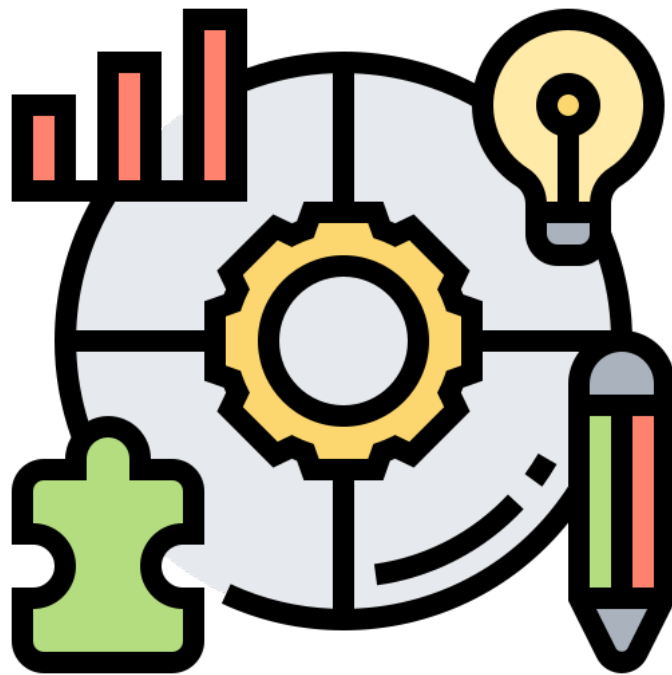

**KEMAHIRAN** : MENGKONSEPSI  
**ELEMENT** : *CONCEPTUALISING*

**BAB 2 : DAYA DAN GERAKAN I / CHAPTER 2 : FORCE AND MOTION I**

**BAHAGIAN A / SECTION A**

- 1 Rajah 1.1 menunjukkan Ali sedang menendang bola dan Rajah 1.2 menunjukkan Ali sedang menendang satu batu.

*Diagram 1.1 shows Ali kicking a football and Diagram 1.2 shows Ali kicking a rock.*



Diagram 1.1

*Rajah 1.1*



Diagram 1.2

*Rajah 1.2*

- (a) Takrifkan daya impuls.  
*Define impulsive force.*

.....  
[1 markah / 1 mark]

- (b) Bandingkan masa perlanggaran dalam Rajah 1.1 dengan Rajah 1.2.  
*Compare the time of impact in Diagram 1.1 with Diagram 1.2.*

.....  
[1 markah / 1 mark]

- (c) Bandingkan daya impuls dalam Rajah 1.1 dengan Rajah 1.2.  
*Compare the impulsive force in Diagram 1.1 with Diagram 1.2*

.....  
 [1 markah / 1 mark]

- (d) Bandingkan kesakitan yang dialami Ali dalam Rajah 1.1 dengan Rajah 1.2.  
*Compare the pain experience by Ali in Diagram 1.1 with Diagram 1.2.*

.....  
 [1 markah / 1 mark]

- (e) Berdasarkan jawapan anda dalam (b), (c) dan (d), nyatakan hubungan antara masa perlanggaran, daya impuls dan kesakitan yang dialami Ali.  
*Based on your answer in (b), (c) and (d), state the relationship between time of impact, impulsive force and pain experienced by Ali.*

.....  
 [1 markah / 1 mark]

- (f) Cadangkan satu cara bagaimana Ali dapat mengurangkan kesakitannya dalam Rajah 1.2.  
*Suggest one way how Ali could reduce his pain in Diagram 1.2.*

.....  
 [1 markah / 1 mark]

- 2** Rajah 2.1 menunjukkan sebuah lori pengangkut. Rajah 2.2 menunjukkan lori pengangkut yang sama membawa kontena barangan.

*Diagram 2.1 shows an empty pickup truck. Diagram 2.2 shows the same pickup truck carrying a crate.*

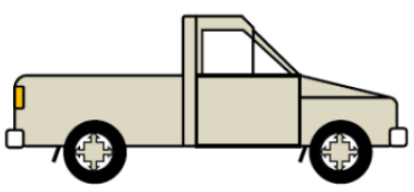

Rajah 2.1  
 Diagram 2.1

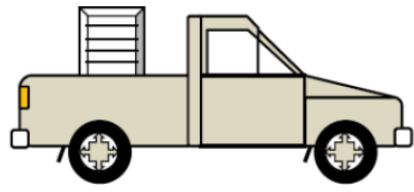

Rajah 2.2  
 Diagram 2.2

(a) Apakah yang dimaksudkan dengan inertia?

*What is meant by inertia?*

.....  
[1 markah / 1 mark]

(b) Bandingkan jisim lori pengangkut dalam Rajah 2.1 dengan jisim lori pengangkut beserta kontena barangan dalam Rajah 2.2.

*Compare the mass of the pickup truck in Diagram 2.1 with the total mass of the pickup truck and crate in Diagram 2.2.*

.....  
[1 markah / 1 mark]

(c) Bandingkan inertia lori pengangkut dalam Rajah 2.1 dengan inertia lori pengangkut dan kontena barangan dalam Rajah 2.2.

*Compare the inertia of pickup truck in Diagram 2.1 with inertia of pickup truck and crate in Diagram 2.2.*

.....  
[1 markah / 1 mark]

(d) Apabila lori pengangkut dalam Rajah 2.2 bergerak ke hadapan tiba-tiba, kontena barangan akan bergerak ke belakang. Terangkan mengapa.

*When pickup truck in Diagram 2.2 suddenly moves forwards, the crate will move backwards. Explain why.*

.....  
[1 markah / 1 mark]

(e) Nyatakan satu contoh kesan inertia yang positif.

*Give one example of positive effect of inertia.*

.....  
[1 markah / 1 mark]

(iii) Rajah 3 menunjukkan laluan jalan kaki ke sekolah bagi seorang pelajar pada setiap hari.

*Diagram 3 shows walking route to school for a student every day.*

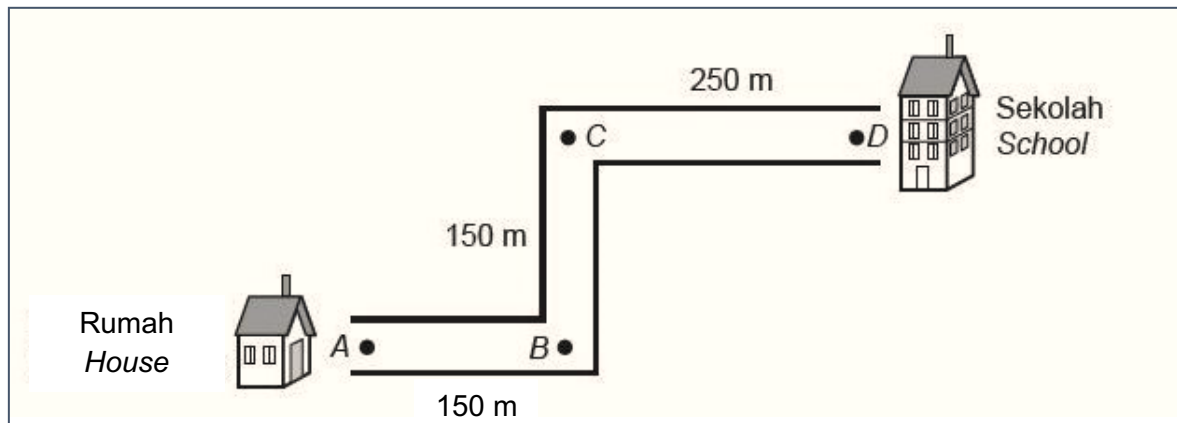

Rajah 3

*Diagram 3*

Perjalanan <i>Route</i>	Masa yang diambil (Minit) <i>Time taken (minutes)</i>
A ke B <i>A to B</i>	10
B ke C <i>B to C</i>	15
C ke D <i>C to D</i>	25

Jadual 3

*Table 3*

(a) Takrifkan jarak.

*Define distance.*

[1 markah / 1 mark]

(b) Kirakan laju pelajar dari A ke B dan nyatakan jawapan dalam unit S.I

*Calculate the speed of the student from A to B and state the answer in S.I unit.*

[2 markah / 2 marks]

- (c) Kirakan laju pelajar dari B ke C dan nyatakan jawapan dalam unit S.I  
*Calculate the speed of the student from B to C and state the answer in S.I unit.*

[2 markah / 2 marks]

- (d) (i) Bandingkan masa A ke B dengan masa B ke C.  
*Compare the time taken from A to B and B to C.*

---

[1 markah / 1 mark]

- (ii) Bandingkan jarak A ke B dengan jarak B ke C.  
*Compare the distance from A to B and B to C.*

---

[1 markah / 1 mark]

- (iii) Bandingkan laju A ke B dengan laju B ke C.  
*Compare the speed from A to B and B to C.*

---

[1 markah / 1 mark]

- (e) Berdasarkan jawapan 1(d), hubungkait masa dengan laju.  
*Based on the answer in 1(d), state the relationship between time and speed.*

---

[1 markah / 1 mark]

## BAHAGIAN B DAN C / SECTION B AND C

- 1 Rajah 1.1 menunjukkan dua ketul bebola plastisin yang serupa sebelum dilepaskan dari ketinggian yang sama. Rajah 1.2 menunjukkan keadaan plastisin itu apabila menghempap kayu dan span. Diperhatikan plastisin itu berhenti dengan lebih cepat apabila menghempap permukaan kayu. *Diagram 1.1 shows two identical spherical plasticine balls before being released from the same height. Diagram 1.2 shows the state of the plasticine balls when they hit the wood and the sponge. It was observed that the plasticine stopped more quickly when it hit the wood.*

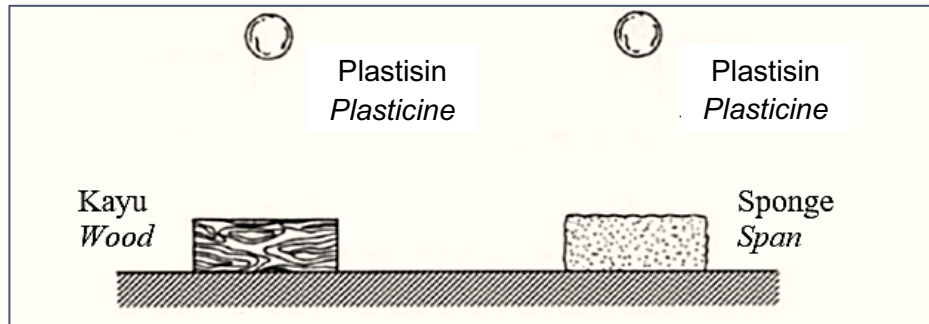

Rajah 1.1  
Diagram 1.1

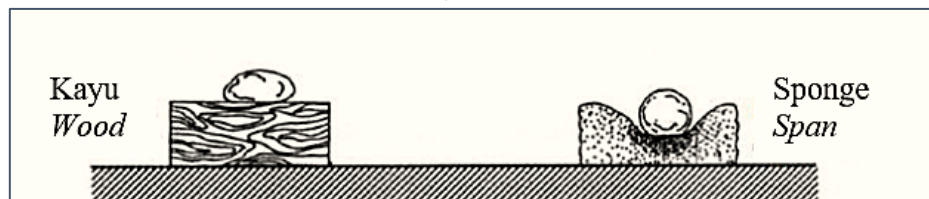

Rajah 1.2  
Diagram 1.2

- (a) (i) Apakah yang dimaksudkan dengan momentum?  
*What does the word momentum mean?*

[1 markah / 1 mark]

- (ii) Perhatikan Rajah 1.1 dan Rajah 1.2, bandingkan bentuk bebola plastisin, permukaan kayu dan permukaan span sebelum dan apabila bebola plastisin menghempap kedua-dua permukaan itu.

Hubungkaitkan perubahan bentuk bebola plastisin dan kedua-dua permukaan itu untuk membuat satu kesimpulan tentang konsep fizik yang berkaitan.

*Observe Diagram 1.1 and Diagram 1.2, compare the shape of the plasticine balls, the surface of the wood and the surface of the sponge before and when the plasticine balls hit the surfaces.*

*Relate the changes in shapes of the plasticine balls and the surfaces to deduce a relevant physics concept.*

[5 markah / 5 marks]

- (b) Terangkan perubahan tenaga yang berlaku semasa plastisin itu dilepaskan sehingga mencapai kedudukan seperti pada Rajah 1.2.

*Explain the changes in energy that occur from the moment the plasticine ball is released until it reaches the position in Diagram 1.2.*

[4 markah / 4 marks]

- 2 Rajah 2.1 menunjukkan sebutir peluru yang ditembak keluar dari sepucuk senapang. Rajah 2.2 menunjukkan seorang penumpang yang sedang berjalan di atas sebuah perahu.

*Diagram 2.1 shows a bullet being shot from a rifle. Diagram 2.2 shows a passenger walking in a boat.*

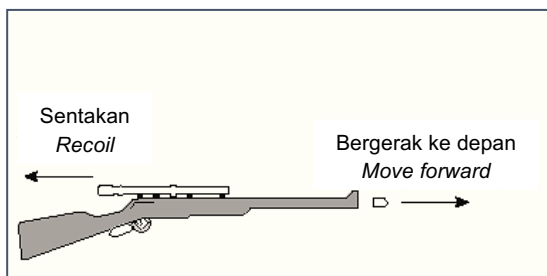

Rajah 2.1  
Diagram 2.1

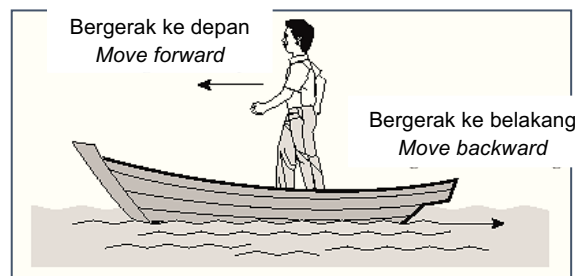

Rajah 2.2  
Diagram 2.2

- (a) (i) Apakah yang dimaksudkan dengan halaju?  
*What is meant by velocity?*

[1 markah / 1 mark]

- (ii) Menggunakan Rajah 2.1 dan Rajah 2.2, nyatakan ciri-ciri sepunya keadaan peluru yang ditembak keluar dari senapang dan penumpang yang sedang berjalan di atas perahu. Seterusnya hubungkan ciri-ciri itu untuk menjelaskan suatu konsep fizik dan namakan konsep itu.

*Using Diagram 2.1 and Diagram 2.2, state the property which is common to the bullet being shot from the rifle and the passenger walking on the boat. Then relate the property to explain a physics concept and name the concept.*

[5 markah / 5 marks]

- (b) Apabila satu cawan kaca jatuh ke atas lantai konkrit, ia akan pecah. Namun begitu, apabila cawan kaca itu jatuh ke atas permaidani dari ketinggian yang sama, ia tidak pecah. Terangkan mengapa?

*When a porcelain cup falls onto a concrete floor, it breaks into pieces. However, when the porcelain cup falls onto a carpet from the same height, it does not break. Explain why?*

[4 markah / 4 marks]

- 3 Rajah 3.1 menunjukkan sebiji belon dilepaskan dari ikatannya. Rajah 3.2 menunjukkan seekor sotong bergerak ke depan apabila melepaskan sejumlah dakwat hitam yang banyak ke belakang. *Diagram 3.1 shows a balloon being released from a grip. Diagram 3.2 shows a cuttlefish moving forward by releasing a big volume of black ink backwards.*

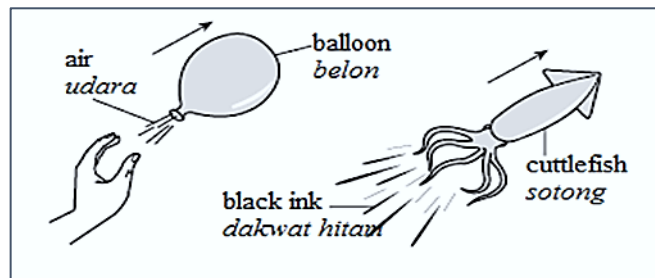

Rajah 3.1

Diagram 3.1

Rajah 3.2

Diagram 3.2

- (a) (i) Apakah yang dimaksudkan dengan daya?

*What is meant by force?*

[1 markah / 1 mark]

- (ii) Menggunakan Rajah 3.1 dan 3.2, bandingkan arah pergerakan belon dan sotong. Kaitkan arah gerakan untuk menyimpulkan satu konsep fizik yang berkaitan.

*Using Diagrams 3.1 and 3.2 compare the direction of motion of the balloon and the cuttlefish. Relate the direction of motion to deduce a relevant physics concept.*

[5 markah / 5 marks]

- (b) Dengan menggunakan contoh-contoh yang sesuai, terangkan cara-cara untuk menggunakan daya impuls.

*Using suitable examples, explain the ways to utilise impulse force.*

[4 markah / 4 marks]

**BAB 3 : KEGRAVITIAN / CHAPTER 3 : GRAVITATION**

**BAHAGIAN A / SECTION A**

1 Beberapa perkara perlu diambil kira sebelum melancarkan satelit ke ruang angkasa lepas.  
*Several things should be taken into consideration before launching a rocket into outer space.*

(a) Nyatakan dua jenis halaju yang perlu diberi perhatian bagi pelancaran satelit.  
*State two types of velocity that should be given attention for launching a satellite.*

.....  
.....

[1 markah / 1 mark]

(b) Dengan menggunakan persamaan daya memusat dan Hukum Kegravitian Semesta Newton, terbitkan persamaan halaju linear bagi objek yang mengorbit.

*By using the centripetal force equation and Newton's Law of Universal Gravitation, derive the linear velocity equation for an orbiting object.*

[3 markah / 3 marks]

(c) Tenaga Keupayaan Graviti diberikan oleh persamaan  $U = -\frac{GMm}{r}$ . Dengan mengambil kira persamaan Tenaga Kinetik, terbitkan persamaan halaju lepas.

*Gravity's Potential Energy is given by the equation  $U = -\frac{GMm}{r}$ . By using the Kinetic Energy's equation, derive the escape velocity's equation.*

[3 markah / 3 marks]

- (d) Sebuah roket dilancarkan ke angkasa lepas dengan halaju  $37 \times 10^3 \text{ ms}^{-1}$ . Roket tersebut mendarat di Planet S yang mempunyai jisim 95 kali lebih besar daripada jisim Bumi. Planet S mempunyai diameter 120536 km.

*A rocket is launched to outer space with the velocity of  $37 \times 10^3 \text{ ms}^{-1}$ . It landed on Planet S which its mass is 95 times larger than Earth. Planet S has a diameter of 120536 km.*

- (i) Tentukan halaju lepas bagi Planet S.

[Jisim Bumi =  $5.97 \times 10^{24} \text{ kg}$ ].

*Define the escape velocity for Planet S.*

[*Earth's mass =  $5.97 \times 10^{24} \text{ kg}$* ].

[2 markah / 2 marks]

- (ii) Adakah roket itu berupaya kembali ke Bumi? Jelaskan jawapan anda.

*Will the rocket be able to return to Earth? Explain your answer.*

.....

.....

.....

[2 markah / 2 marks]

- 2 Rajah 2 menunjukkan dua satelit A dan B.

*Diagram 2 shows two satellites A and B.*

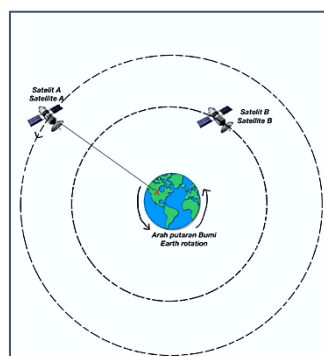

Rajah 2

*Diagram 2*

Satelit A sentiasa berada di tempat yang sama pada kedudukan X dan mengorbit mengikut arah putaran Bumi.

*Satellite A is always in the same place at position X and orbits in the direction of the Earth's rotation.*

- (a) Namakan daya yang bertindak sebagai daya yang mengekalkan satelit dalam orbit.

*Name the force that acts as the force that keeps the satellite in orbit.*

.....

[1 markah / 1 mark]

- (b)  $G = 6.67 \times 10^{-11} \text{ Nm}^2\text{kg}^{-2}$

Jisim Bumi / *Earth's mass*,  $M = 5.97 \times 10^{24} \text{ kg}$

Jejari Bumi / *Earth's radius*,  $R = 6.37 \times 10^6 \text{ m}$

- (i) Hitung laju linear satelit A yang mengorbit bumi pada ketinggian 1500 km.

*Calculate the linear speed of satellite A orbiting the earth at an altitude of 1500 km.*

[2 markah / 2 marks]

- (ii) Hitung laju linear satelit B yang mengorbit bumi pada ketinggian 620 km.

*Calculate the linear speed of satellite B orbiting the earth at an altitude of 620 km.*

[2 markah / 2 marks]

(c) Berdasarkan Rajah 2,  
*Based on Diagram 2,*

(i) Bandingkan jarak satelit A dan B dari pusat Bumi.  
*Compare the distance of satellites A and B from the center of the Earth.*

.....  
[1 markah / 1 mark]

(ii) Bandingkan laju linear satelit A dan B dalam orbit masing-masing.  
*Compare the distance of satellites A and B from the center of the Earth.*

.....  
[1 markah / 1 mark]

(iii) Hubungkan jarak dari pusat Bumi dengan laju linear satelit.  
*Relate the distance from the center of the Earth to the linear speed of the satellite.*

.....  
.....  
[1 markah / 1 mark]

(d) Nyatakan dua ciri satelit A yang berbeza daripada satelit B.  
*State two characteristics of satellite A that are different from satellite B.*

.....  
[2 markah / 2 marks]

(e) Apakah yang terjadi kepada satelit A apabila laju linearnya berkurang? Berikan satu sebab.  
*What happens to satellite A when its linear speed decreases? Give one reason.*

.....  
.....  
.....  
[2 markah / 2 marks]

**BAHAGIAN B DAN C / SECTION B AND C**

- 1 (a) Nyatakan maksud daya graviti.  
*State the meaning of gravitational force.*

[1 markah / 1 mark]

(b)

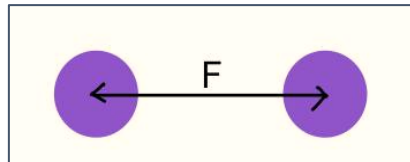

Rajah 1.1  
*Diagram 1.1*

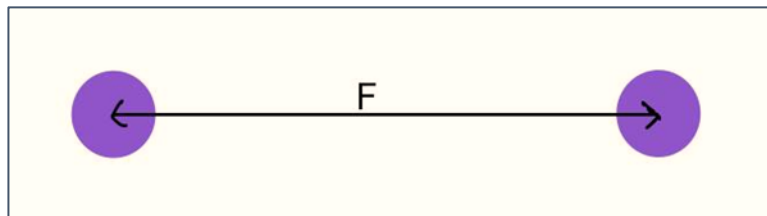

Rajah 1.2  
*Diagram 1.2*

Rajah 1.1 dan Rajah 1.2 menunjukkan empat objek sama berbentuk sfera dengan jisim 200 kg. Jarak antara pusat objek di Rajah 1.1 ialah 25 m manakala jarak antara pusat objek di rajah 1.2 ialah 55 m.

*Diagram 1.1 and Diagram 1.2 show four identical spherical objects with a mass of 200 kg. The distance between the centers of the objects in Diagram 1.1 is 25 m while the distance between the centers of the objects in Diagram 1.2 is 55 m.*

Berdasarkan maklumat yang diberi,  
*Based on the information given,*

- (i) Hitungkan daya graviti dalam Rajah 1.1.  
*Calculate the gravitational force in Diagram 1.1.*

[2 markah / 2 marks]

- (ii) Hitungkan daya graviti dalam Rajah 1.2.  
*Calculate the gravitational force in Diagram 1.2.*

[2 markah / 2 marks]

- (iii) Bandingkan nilai daya graviti dalam Rajah 1.1 dan Rajah 1.2.  
*Compare the values of gravitational force in Diagram 1.1 and Diagram 1.2.*

[1 markah / 1 mark]

- (iv) Hubungkaitkan jarak antara pusat objek dengan daya graviti.  
*Relate the distance between the center of an object to the force of gravity.*

[1 markah / 1 mark]

(c)

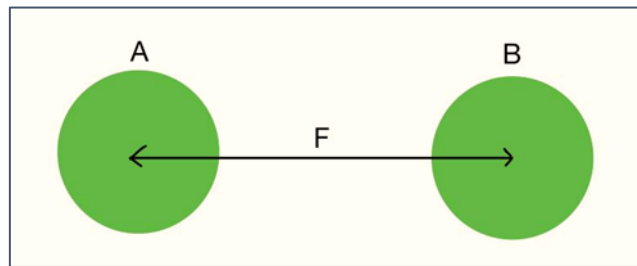

Rajah 1.3

Diagram 1.3

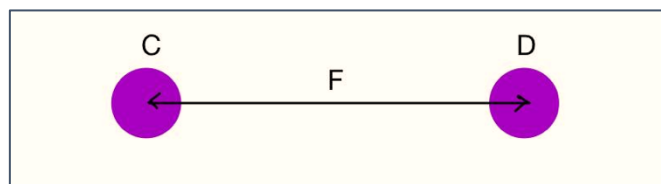

Rajah 1.4

Diagram 1.4

Rajah 1.3 dan Rajah 1.4 menunjukkan objek A, B, C dan D. Jarak antara objek A dan B dengan objek C dan D adalah sama iaitu 30 m. Jisim objek A dan B adalah sama iaitu 200 kg. Jisim objek C dan D ialah 100 kg.

*Diagram 1.3 and Diagram 1.4 shows objects A, B, C and D. The distance between objects A and B and objects C and D is the same which is 30 m. The masses of objects A and B are the same which is 200 kg. The mass of objects C and D is 100 kg.*

Berdasarkan maklumat yang diberi,

*Based on the information given,*

- (i) Hitungkan daya graviti dalam Rajah 1.3.  
*Calculate the gravitational force in Diagram 1.3.*

[2 markah / 2 marks]

- (ii) Hitungkan daya graviti dalam Rajah 1.4.  
*Calculate the gravitational force in Diagram 1.4.*
- [2 markah / 2 marks]
- (iii) Bandingkan nilai daya gravity dalam Rajah 1.3 dan Rajah 1.4.  
*Compare the values of gravitational force in Diagram 1.3 and Diagram 1.4.*
- [1 markah / 1 mark]
- (iv) Hubungkan jisim objek dengan daya graviti.  
*Relate the mass of object to the force of gravity.*
- [1 markah / 1 marks]
- (d) Sebuah satelit berjisim  $1.55 \times 10^3$  kg dilancarkan dari permukaan Bumi ke orbit dengan jejari  $3.8 \times 10^7$  m. Bandingkan daya graviti ke atas satelit itu sebelum pelancaran dengan daya graviti semasa satelit itu berada dalam orbit.  
*A satellite of mass  $1.55 \times 10^3$  kg is launched from the Earth's surface into orbit with a radius of  $3.8 \times 10^7$  m. Compare the force of gravity on the satellite before launch with the force of gravity while the satellite is in orbit.*
- [5 markah / 5 marks]

# BAB 4 : HABA / CHAPTER 4 : HEAT

## BAHAGIAN A / SECTION A

- 1 Rajah 1.1 dan Rajah 1.2 menunjukkan satu eksperimen yang dilakukan untuk mengkaji hubungan di antara suhu dan tekanan gas. Rajah 1.1 menunjukkan bikar dipanaskan selama 5 minit manakala Rajah 1.2 menunjukkan bikar dipanaskan selama 10 minit.

*Diagram 1.1 and Diagram 1.2 show an experiment to study the relationship between the temperature and the pressure of gas. Diagram 1.1 shows the beaker is heated for 5 minutes while Diagram 1.2 shows the beaker is heated for 10 minutes.*

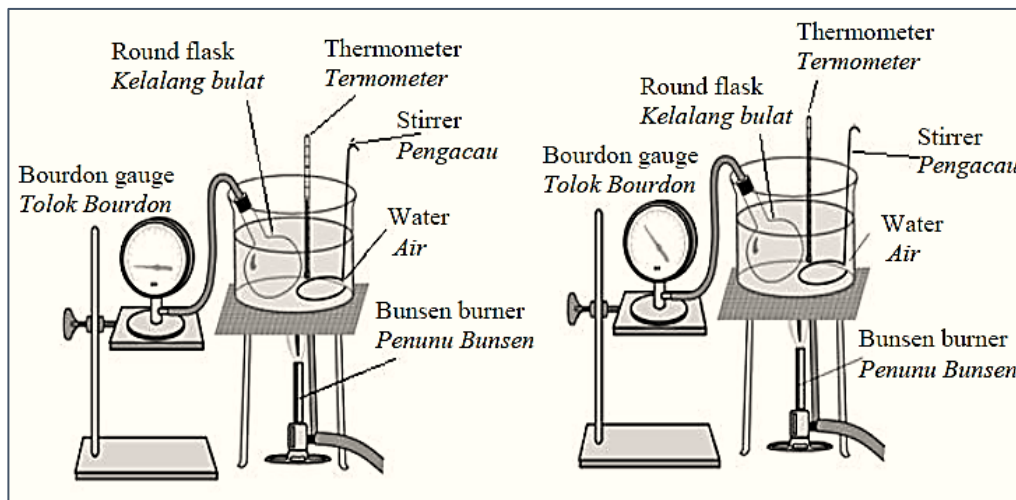

Rajah 1.1

Diagram 1.1

Rajah 1.2

Diagram 1.2

Berdasarkan Rajah 1.1 dan 1.2,  
Based on Diagram 1.1 and 1.2,

- (a) Bandingkan:

*Compare:*

- (i) suhu udara terperangkap di dalam kelalang bulat.  
*temperature of the trapped air inside the round flask.*

.....

[1 markah / 1 mark]

- (ii) bacaan tolok Bourdon  
*Reading of Bourdon Gauge*

.....

[1 markah / 1 mark]

- (iii) isipadu udara terperangkap di dalam kelalang bulat.  
*the volume of trapped air inside round flask.*

.....  
 [1 markah / 1 mark]

- (b) Menggunakan jawapan anda di 1(a)(i) dan 1(a)(ii), nyatakan hubungan di antara suhu udara terperangkap dan kuantiti fizikal yang diukur oleh tolok Bourdon.  
*Using your answer in 1(a)(i) and 1(a)(ii), state a relationship between the temperature of the trapped air and the physical quantity measured by the Bourdon gauge.*

.....  
 [1 markah / 1 mark]

- (c) Menggunakan Teori Kinetik Jirim, terangkan jawapan anda di 1(b)  
*Using the Kinetic Theory of Matter, explain your answer in 1(b).*

.....  
 [2 markah / 2 marks]

- 2 Rajah 2.1 dan Rajah 2.2 menunjukkan dua turus udara yang terperangkap dipanaskan dengan kuantiti haba yang berlainan. Penunu Bunsen dalam Rajah 2.1 dipadamkan selepas 7 minit manakala penunu bunsen dalam Rajah 2.2 dipadamkan selepas 10 minit.  
*Diagram 2.1 and Diagram 2.2 show two trapped air column are heated with different quantity of heat. Bunsen burner in Diagram 2.1 is turned off after 7 minutes while bunsen burner in Diagram 2.2 is turned off after 10 minutes.*

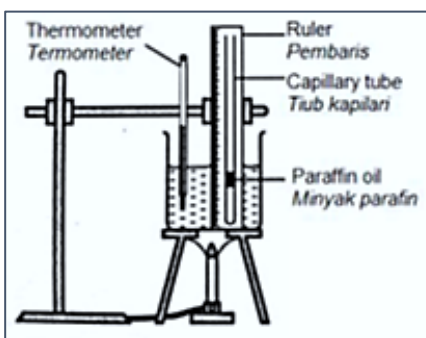

Rajah 2.1  
 Diagram 2.1

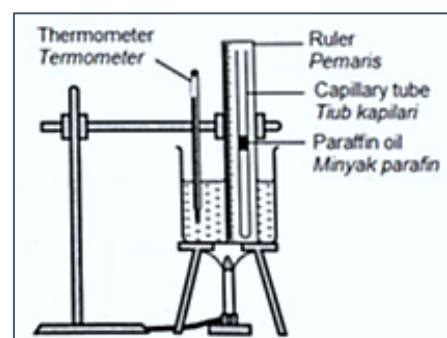

Rajah 2.2  
 Diagram 2.2

Berdasarkan Rajah 2.1 dan 2.2,

Based on Diagram 2.1 and 2.2,

(a) *Bandingkan :*

Compare :

(i) bacaan kedua-dua termometer

*Compare the readings of both thermometers*

.....

[1 markah / 1 mark]

(ii) ketinggian minyak parafin

*height of paraffin oils*

.....

[1 markah / 1 mark]

(b) Menggunakan jawapan anda di 2(a)(i) dan 2(a)(ii), nyatakan hubungkait

*Using your answer in 2(a)(i) and 2(a)(ii), state a relationship*

(i) haba yang dibekalkan dengan isipadu udara yang terperangkap di dalam tiub kapilari.

*heat supplied and the volume of air trapped in the capillary tube*

.....

[1 markah / 1 mark]

(ii) isi padu udara yang terperangkap di dalam tiub kapilari dengan suhu.

*the volume of air trapped in the capillary tube and the temperature.*

.....

[1 markah / 1 mark]

(c) Menggunakan Teori Kinetik Jirim, terangkan jawapan anda di 1(b)

*Using the Kinetic Theory of Matter, explain your answer in 1 (b).*

.....

.....

[2 markah / 2 marks]

## BAHAGIAN B DAN C / SECTION B AND C

- 1 Rajah 1.1 menunjukkan dua bikar A dan B mengandungi cecair yang sama tetapi berlainan jisim. Rajah 1.2 menunjukkan suhu cecair di dalam bikar A dan bikar B itu selepas masing-masing dipanaskan selama 10 minit oleh pemanas rendam 240 V, 50 W.

*Diagram 1.1 shows two beakers, A and B containing identical liquid but of different masses. Diagram 1.2 shows the temperature of the liquid in beaker A and beaker B after 10 minutes being heated by 240 V, 50 W of immersion heater respectively.*

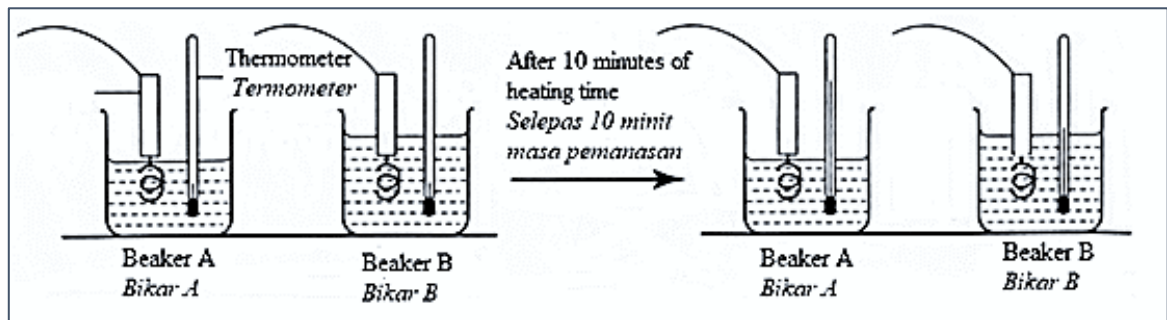

Rajah 1.1

Diagram 1.1

Rajah 1.2

Diagram 1.2

- (a) Menggunakan Rajah 1.1, bandingkan jisim cecair di dalam bikar, kenaikan suhu, muatan haba tentu bagi cecair dan jumlah haba yang dibekalkan.

Hubungkaitkan jisim cecair di dalam bikar dengan kenaikan suhu.

*Observe Diagram 1.1, compare the mass of liquid in the beaker, and the rise of the temperature of water, specific heat capacity of the liquid and the total heat supplied.*

*State the relationship between the mass of the liquid and the rise of the temperature in the beaker.*

[5 markah / 5 marks]

- 2 Rajah 2.1 menunjukkan dua kualiti M dan N yang diperbuat daripada bahan yang berbeza, dengan muatan haba tentu yang berbeza, digunakan untuk mendidihkan air yang sama isipadu.

Rajah 2.2 menunjukkan masa yang digunakan untuk mendidihkan air. Ketika air mendidih, kualiti dan air berada dalam keseimbangan terma.

[Anggap saiz dan ketebalan bagi kualiti M dan kualiti N adalah sama.]

Diagram 2.1 below shows two frying pans M and N are made of different materials with different heat capacity, are used to boil the same volume of water.

Diagram 2.2 below shows the time taken for the water to boil. When boiling, the frying pan and the water are in thermal equilibrium.

[Assume frying pan M and frying pan N are of the same size and same thickness].

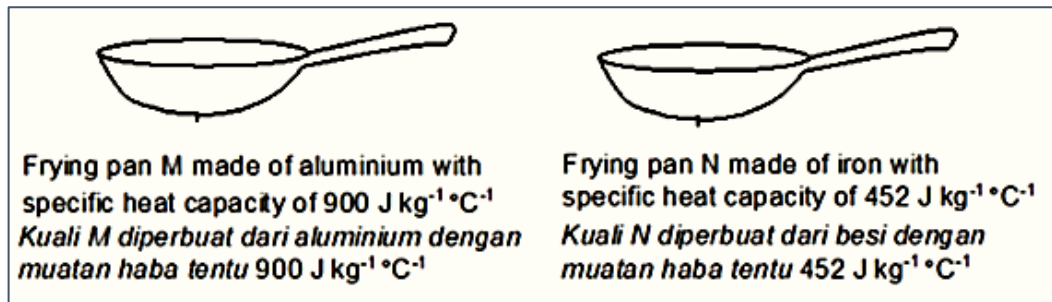

Rajah 2.1

Diagram 2.1

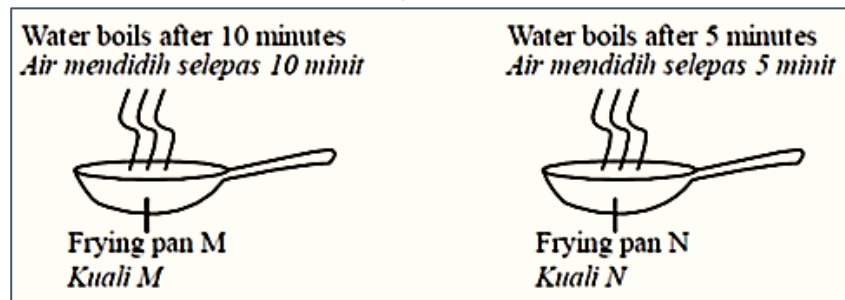

Rajah 2.2

Diagram 2.2

- (a) Perhatikan Rajah 2.1 dan Rajah 2.2, bandingkan muatan haba tentu kuali, masa yang diambil oleh air untuk mendidih dan perubahan dalam kenaikan suhu. Nyatakan hubungan antara muatan haba tentu kuali dengan masa yang diambil oleh air untuk mendidih. Buat kesimpulan tentang hubungan antara muatan haba tentu kuali dengan kadar perubahan suhu bagi kuali.

Observe Diagram 2.1 and Diagram 2.2, compare the specific heat capacity of the frying pan, the time taken for the water to boil and the change in temperature.

State the relationship between the specific heat capacity of the frying pan with the time taken for the water to boil. Make a deduction regarding the relationship between the specific heat capacity of the frying pan and the rate of change in temperature of the frying pan.

[5 markah / 5 marks]

- 3 Rajah 3.1 dan Rajah 3.2 menunjukkan satu eksperimen untuk menentukan hubungan antara isipadu gas terperangkap dan tekanan yang dikenakan dalam tiub kaca.

*Diagram 3.1 and Diagram 3.2 show an experiment to determine the relationship between volume of trapped gas and pressure that is exerted in a glass tube.*

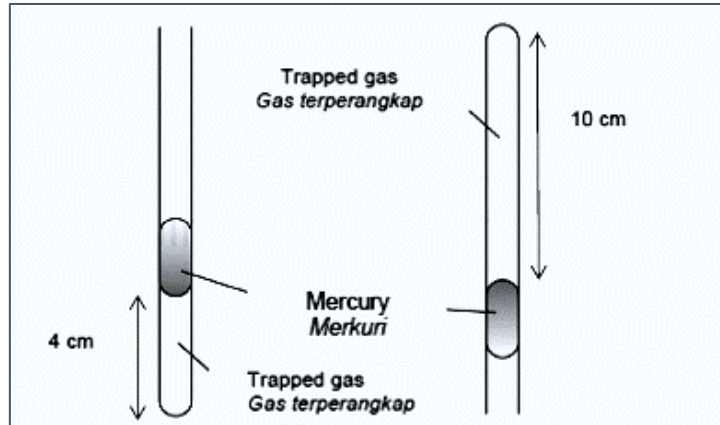

Rajah 3.1  
Diagram 3.1

Rajah 3.2  
Diagram 3.2

- (a) Perhatikan Rajah 3.1 dan 3.2. Bandingkan isi padu gas terperangkap, tekanan yang dikenakan untuk membuat deduksi tentang satu hukum fizik. Namakan hukum fizik yang terlibat.  
*Observe Diagram 3.1 and 3.2. Compare the volume of trapped gas, pressure, and the temperature. Relate the volume of trapped gas to the pressure exerted to deduce one physics law. Name the physics law.*

[5 markah / 5 marks]

# BAB 5 : GELOMBANG / CHAPTER 5 : WAVES

## BAHAGIAN A / SECTION A

1 Rajah 1 menunjukkan spektrum elektromagnet.

*Diagram 1 shows the electromagnetic spectrum.*

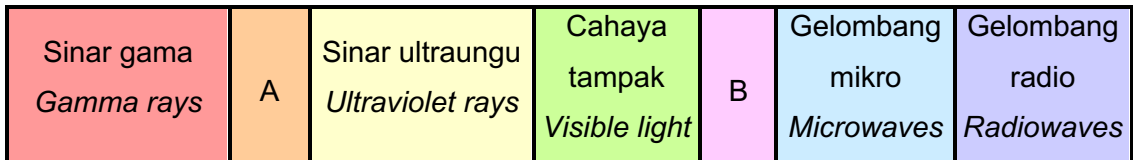

Rajah 1  
*Diagram 1*

(a) Namakan gelombang elektromagnet A dan B.

*Name the electromagnetic waves A and B.*

A : .....

B : .....

[2 markah / 2 marks]

(b) Berikan satu ciri gelombang elektromagnet.

*Give one characteristic of electromagnetic waves.*

.....

[1 markah / 1 mark]

(c) Bandingkan panjang gelombang A dan B.

*Compare the wavelengths of A and B.*

.....

[1 markah / 1 mark]

(d) Bandingkan frekuensi A dan B.

*Compare the frequencies of A and B.*

.....

[1 markah / 1 mark]

- (e) Bandingkan halaju A dan B.  
*Compare the velocities of A and B.*

.....  
 [1 markah / 1 mark]

- (f) Namakan gelombang electromagnet yang digunakan dalam alat kawalan jauh televisyen.  
*Name the electromagnetic wave used in the operation of a TV's remote control.*

.....  
 [1 markah / 1 mark]

- 2 Rajah 2.1 dan Rajah 2.2 menunjukkan corak pinggir yang dihasilkan apabila dua cahaya monokromatik yang sama melalui dua dwicelah dengan lebar yang berbeza.  
*Diagram 2.1 and Diagram 2.2 show the fringes patterns produced when two identical monochromatic lights passing through two double slits of different width.*

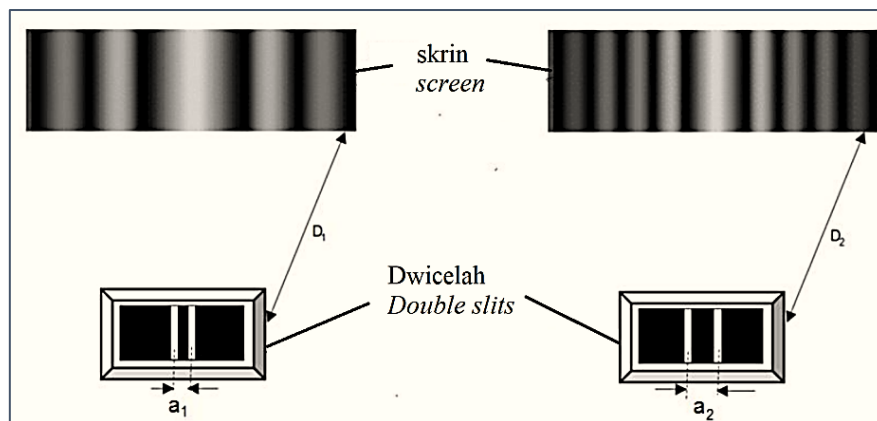

Rajah 2.1  
 Diagram 2.1

Rajah 2.2  
 Diagram 2.2

Menggunakan Rajah 2.1 dan 2.2, bandingkan:  
*Using Diagram 2.1 and Diagram 2.2, compare:*

- (a) Jarak di antara dua celah,  $a$   
*The distance between the two slits,  $a$ .*

.....  
 [1 markah / 1 mark]

(b) Panjang gelombang,  $\lambda$  bagi cahaya monokromatik itu.

*The wavelength,  $\lambda$  of the monochromatic light.*

.....  
[1 markah / 1 mark]

(c) Jarak di antara dwicelah dan skrin, D.

*The distance between the double slits and the screen, D.*

.....  
[1 markah / 1 mark]

(d) Jarak di antara pinggir-pinggir, x yang terhasil di atas skrin.

*The distance between the fringes, x produced on the screen.*

.....  
[1 markah / 1 mark]

(e) Nyatakan hubungan antara x dan a

*State the relationship between x and a.*

.....  
[1 markah / 1 mark]

**3** Rajah 3.1 dan Rajah 3.2 menunjukkan satu eksperimen dwicelah Young untuk menentukan panjang gelombang cahaya monokromatik. Rajah 3.1 menggunakan sumber cahaya berwarna biru manakala Rajah 3.2 menggunakan sumber cahaya berwarna merah.  
*Diagram 3.1 and Diagram 3.2 shows an experiment to determine the wavelength of monochromatic light waves. Diagram 3.1 used a blue light source and Diagram 3.2 used a red light source.*

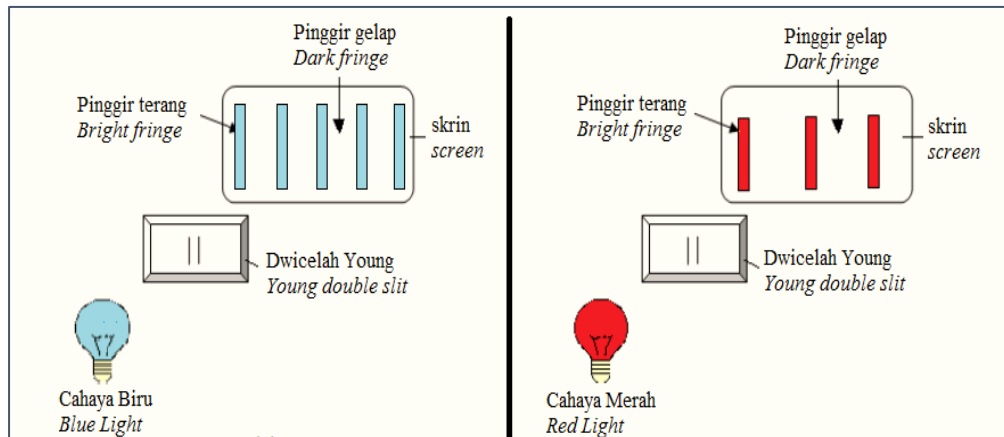

Rajah 3.1  
Diagram 3.1

Rajah 3.2  
Diagram 3.2

Pemisahan dua celah,  $a$ , dan jarak antara dwicalah dengan skrin,  $D$ , dalam kedua-dua rajah adalah malar. Pinggir-pinggir gelap dan terang dihasilkan setelah cahaya merambat melalui celah.  
*The separation between two slits,  $a$ , and the distance between the double slit and the screen,  $D$ , in both diagrams are constant. The dark and bright fringes are produced after the light passes through the slit.*

- (a) Apakah yang dimaksudkan dengan cahaya monokromatik?

*What is meant by monochromatic light?*

.....

[1 markah / 1 mark]

- (b)

- (i) Bandingkan panjang gelombang cahaya merah dan cahaya biru.

*Compare the wavelength of red light and blue light.*

.....

[1 markah / 1 mark]

- (ii) Bandingkan jarak antara pinggir-pinggir terang berturutan bagi cahaya merah dan cahaya biru.

*Compare the distance of consecutive bright fringes for red light and blue light.*

.....

[1 markah / 1 mark]

- (c) Nyatakan hubungkait antara panjang gelombang dengan jarak antara pinggir-pinggir terang berturutan dalam eksperimen ini.

*Relate the wavelength and the distance between consecutive bright fringes in this experiment.*

.....

[1 markah / 1 mark]

(d)

- (i) Apakah yang akan berlaku kepada jarak antara pinggir-pinggir terang jika pemisahan antara dua celah ditambah?

*What happens to the distance between two consecutive bright fringes if the separation between two slits is increased?*

.....

[1 markah / 1 mark]

- (ii) Berikan sebab bagi jawapan anda di (d) (i).

*Give a reason for your answer in (d) (i).*

.....

[1 markah / 1 mark]

- (e) Nyatakan fenomena fizik yang berkaitan dalam eksperimen ini.

*State the relevant physics phenomenon which occurs in this experiment.*

.....

[1 markah / 1 mark]

## BAHAGIAN B DAN C / SECTION B AND C

- 1 Rajah 1(a) dan Rajah 1(b) menunjukkan corak interferens menggunakan sumber koheren gelombang air.

*Diagram 1(a) and Diagram 1(b) show the pattern of interference using coherent source of water waves.*

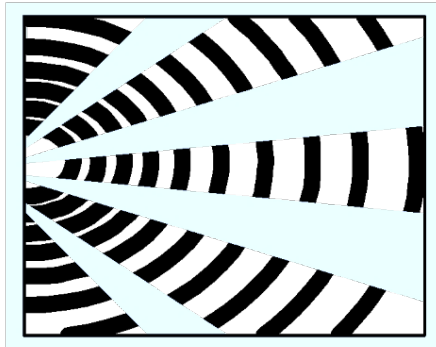

Rajah 1(a)

*Diagram 1(a)*

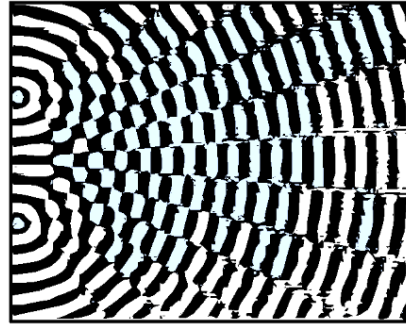

Rajah 1(b)

*Diagram 1(b)*

- (a) Menggunakan Rajah 1(a) dan Rajah 1(b) bandingkan jarak di antara dua sumber koheren, panjang gelombang bagi gelombang air yang merambat dan jarak di antara dua garis antinod berturutan.

*Using Diagram 1(a) and Diagram 1(b) compare the distance between the two coherent sources, wavelength of the propagating water waves and distance between two constructive antinodes.*

[3 markah / 3 marks]

- (b) Hubungkan jarak di antara dua sumber koheren dengan jarak di antara dua garis antinod berturutan.

*Relate the distance between the two coherent sources with the distance between two constructive antinodes.*

[1 markah / 1 mark]

- 2 Rajah 2(a) menunjukkan pinggir-pinggir merah yang terbentuk dalam eksperimen dwicelah Young.

*Diagram 2(a) shows the red fringes formed in a Young's double slit experiment.*



Rajah 2(a)

*Diagram 2(a)*

Rajah 2(b) menunjukkan pinggir-pinggir hijau yang terbentuk apabila cahaya merah yang mempunyai panjang gelombang  $7.0 \times 10^{-7}$  m diganti dengan cahaya hijau yang mempunyai panjang gelombang  $5.0 \times 10^{-7}$  m.

*Diagram 2(b) shows the green fringes formed when the red light of wavelength  $7.0 \times 10^{-7}$  m is replaced by the green light of wavelength  $5.0 \times 10^{-7}$  m.*



Rajah 2(b)

*Diagram 2(b)*

Berdasarkan Rajah 2(a) dan Rajah 2(b), bandingkan panjang gelombang bagi sumber cahaya yang digunakan, jarak antara dua pinggir berturutan yang terbentuk oleh cahaya-cahaya itu dan jarak antara dua pinggir berturutan bagi cahaya merah dan cahaya hijau. Hubungkan panjang gelombang cahaya dengan jarak antara dua pinggir berturutan. Namakan fenomena gelombang yang terlibat.

*Based on Diagram 2(a) and Diagram 2(b), compare the wavelength of the light source used, the distance between two consecutive fringes formed by the respective light and the distance between two consecutive fringes of red light and green light. Relate the wavelength of the light with the distance between two consecutive fringes. Name the wave phenomenon involved.*

[5 markah / 5 marks]

## BAB 6 : CAHAYA DAN OPTIK / CHAPTER 6 : LIGHT AND OPTICS

### BAHAGIAN A / SECTION A

- 1 Rajah 1.1 dan Rajah 1.2 menunjukkan kedudukan imej yang dilihat oleh seorang pemerhati apabila dua keping syiling serupa diletakkan di dalam gelas yang serupa dengan ketinggian air yang berbeza. Rajah 1.3 menunjukkan graf dalam nyata melawan dalam ketara bagi air itu.

*Diagram 1.1 and Diagram 1.2 show the positions of the image seen by an observer when two identical coins are placed in the identical glass with different height of water. Diagram 1.3 shows a graph of real depth against apparent depth of the water.*

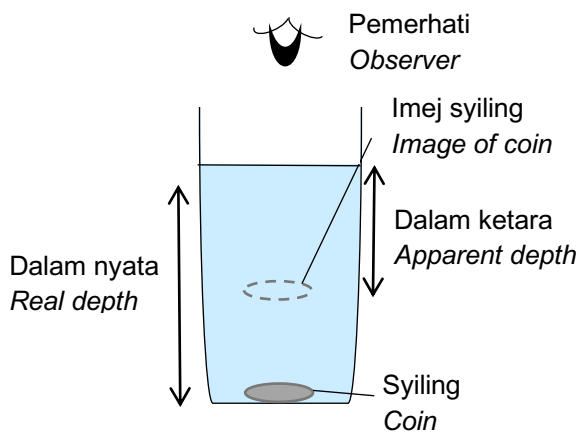

Rajah 1.1  
Diagram 1.1

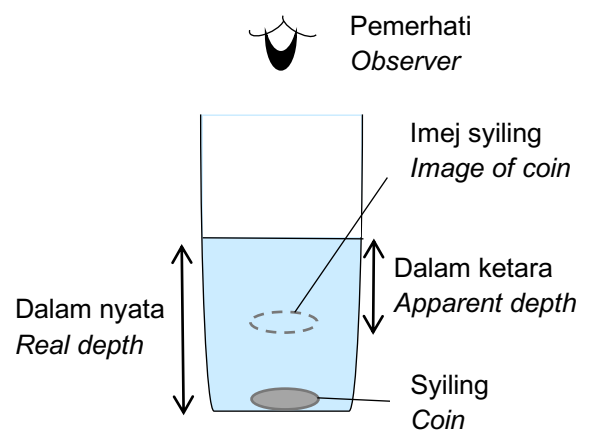

Rajah 1.2  
Diagram 1.2

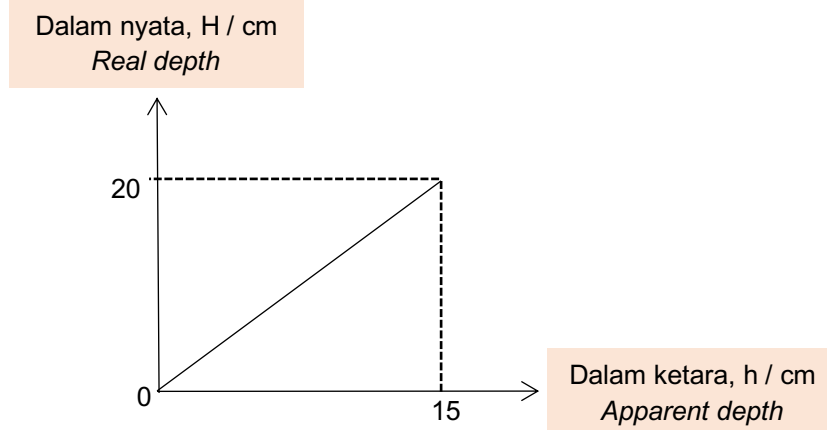

Rajah 1.3  
Diagram 1.3

(a) Namakan fenomena cahaya yang terlibat.

*Name the light phenomenon involved.*

.....  
[1 markah / 1 mark]

(b) Perhatikan Rajah 1.1 dan Rajah 1.2

*Observe Diagram 1.1 and Diagram 1.2*

(i) bandingkan dalam nyata duit syiling itu  
*compare the real depth of the coin.*

.....  
[1 markah / 1 mark]

(ii) bandingkan dalam ketara duit syiling yang dilihat oleh pemerhati  
*compare the apparent depth of the coin seen by the observer.*

.....  
[1 markah / 1 mark]

(iii) hubungkaitkan dalam nyata dengan dalam ketara  
*relate the real depth to the apparent depth.*

.....  
[1 markah / 1 mark]

(c) (i) Namakan kuantiti fizik yang mewakili kecerunan graf dalam nyata  
melawan dalam ketara itu.

*Name a physical quantity that represent gradient of the graph real depth  
against apparent depth.*

.....  
[1 markah / 1 mark]

(ii) Hubung kait dalam nyata, dalam ketara dan kuantiti fizik di (c)(i).

*Relate the real depth, apparent depth and physical quantity in (c)(i).*

.....  
[1 markah / 1 mark]

- (iii) Hitung magnitud kuantiti fizik dalam (c)(i) berdasarkan Rajah 1.3.  
*Calculate the magnitude of physical quantity in (c)(i) based on Diagram 1.3.*

[2 markah / 2 marks]

- (d) Air di dalam gelas dalam Rajah 1.1 digantikan dengan air garam yang mempunyai ketumpatan lebih tinggi dengan isipadu yang sama.

*The water in the glass in Diagram 1.1 is replaced by salt water that have higher density with same volume.*

- (i) Apakah yang berlaku kepada kedudukan imej syiling yang dilihat oleh pemerhati dalam : garam tersebut?

*What happens to the position of image of coin seen by the observer in the salt water?*

.....

[1 markah / 1 mark]

- 2 Rajah 2.1 dan Rajah 2.2 menunjukkan sinar cahaya dari dua objek yang serupa melalui kanta cembung, J dan K. Kedua-dua kanta tersebut menghasilkan imej maya. F ialah titik fokus untuk setiap kanta.

*Diagram 2.1 and 2.2 show the light rays from two identical objects passing through the convex lenses, J and K. Both the lenses produce virtual images. F is the focal point for each lens.*

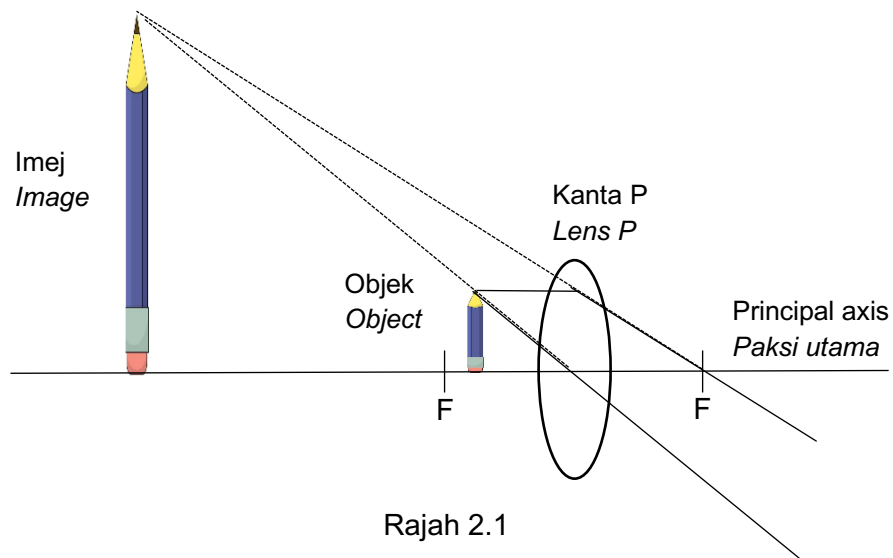

Rajah 2.1  
 Diagram 2.1

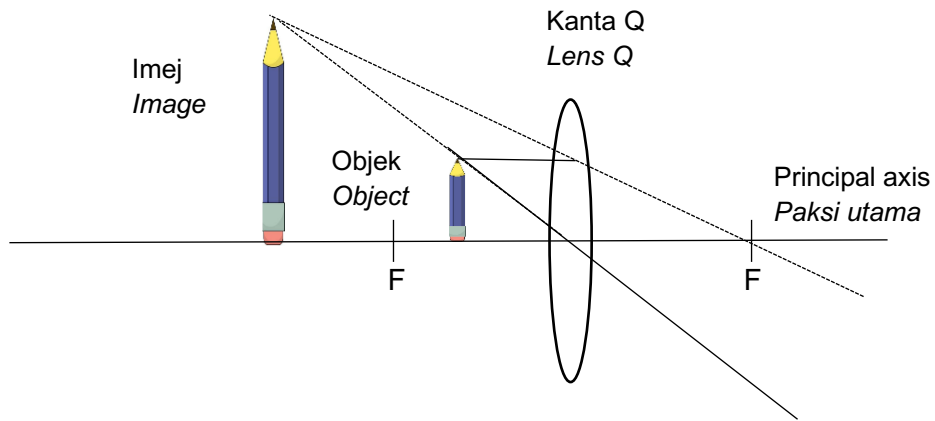

Rajah 2.2  
Diagram 2.2

- (a) Apakah yang maksud imej maya?  
*What is meant by virtual image?*

.....  
[1 markah / 1 mark]

- (b) Perhatikan Rajah 2.1 dan Rajah 2.2  
*Observe Diagram 2.1 and Diagram 2.2*

- (i) bandingkan ketebalan kanta P dan kanta Q  
*compare the thickness of the lenses P and Q*

.....  
[1 markah / 1 mark]

- (ii) bandingkan panjang fokus kanta P dan kanta Q  
*compare the focal length of lenses P and Q*

.....  
[1 markah / 1 mark]

- (iii) bandingkan saiz imej yang dihasilkan oleh kanta P dan kanta Q  
*compare the size of image produced by lenses P and Q*

.....  
[1 markah / 1 mark]

- (iv) hubungkan antara saiz imej dengan panjang fokus.  
*relate the size of image with focal length.*

.....  
 [1 markah / 1 mark]

- (c) Berdasarkan jawapan di 2(b), nyatakan kesimpulan antara kuasa kanta dan panjang fokus.  
*Based on the answer in 2(b), state a conclusion between power of the lens and focal length.*

.....  
 [1 markah / 1 mark]

- (d) Rajah 2.3 menunjukkan gambarajah sinar pembentukan imej oleh kanta bersaiz kecil dalam kamera telefon pintar dan CCTV yang tidak lengkap.  
*Diagram 2.3 show an incomplete ray diagram of formation of image by small lens in smartphone camera and CCTV.*

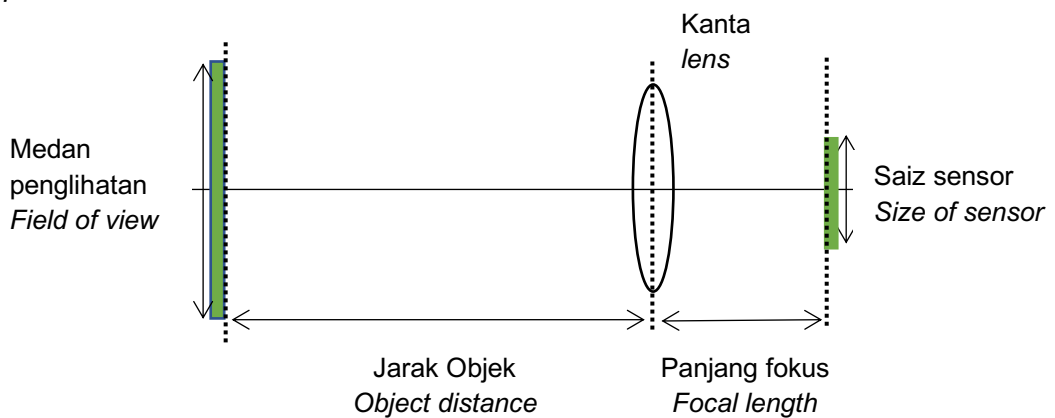

Rajah 2.3  
 Diagram 2.3

- (i) Lengkapkan rajah sinar untuk menunjukkan bagaimana imej terbentuk pada sensor.  
*Complete the ray diagram to show how the image is formed at sensor.*  
 [2 markah / 2 marks]
- (ii) Nyatakan **satu** ciri imej yang terbentuk selain diperkecilkan.  
*State one characteristic of the image formed besides smaller.*

.....  
 [1 mark / 1 markah]

## BAHAGIAN B DAN C / SECTION B AND C

- 1 Rajah 1.1 dan Rajah 1.2 menunjukkan sinar cahaya merambat melalui dua medium dengan sudut genting yang berbeza.

*Diagram 1.1 and Diagram 1.2 show a light ray passing through different medium with different critical angle.*

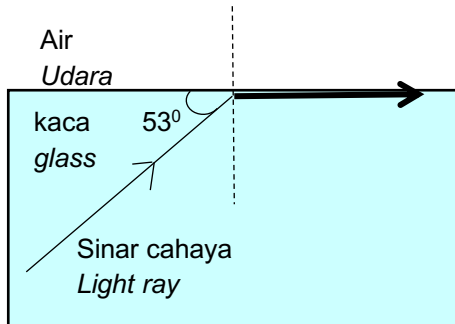

Ketumpatan kaca  
*Density of glass = 2.4 g / cm<sup>3</sup>*

Rajah 1.1  
*Diagram 1.1*

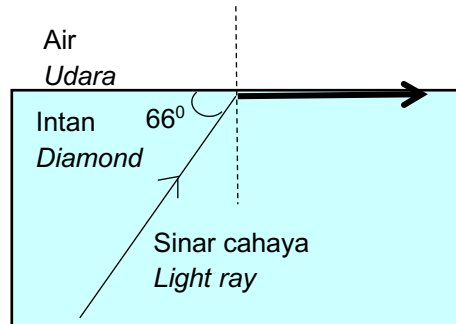

Ketumpatan intan  
*Density of diamond = 3.5 g / cm<sup>3</sup>*

Rajah 1.2  
*Diagram 1.2*

- (a) Apakah maksud sudut genting  
*What is meant by critical angle?*

[1 markah / 1 mark]

- (b) Berdasarkan Rajah 1.1 dan Rajah 1.2,  
*Based on Diagram 1.1 and Diagram 1.2,*

- (i) bandingkan ketumpatan medium, sudut tuju dan sudut biasan.  
*compare the density of the medium, the incident angle and the refracted angle.*

[3 markah / 3 marks]

- (ii) hubungkaitkan sudut tuju dengan sudut genting.  
*relate the critical angle to incident angle.*

[1 markah / 1 mark]

- (iii) nyatakan hubungan antara sudut genting dengan ketumpatan medium.  
*state the relationship between the critical angle and the density of the medium.*

[1 markah / 1 mark]

- 2 Rajah 2.1 dan Rajah 2.2 menunjukkan sinar cahaya selari yang ditujukan kepada cermin cembung, M dan N. F ialah titik fokus dan P ialah kutub untuk setiap cermin cembung itu.

*Diagram 2.1 and Diagram 2.2 show parallel light rays incident on convex mirrors, M and N. F is the focal point and P is the pole of each convex mirror.*

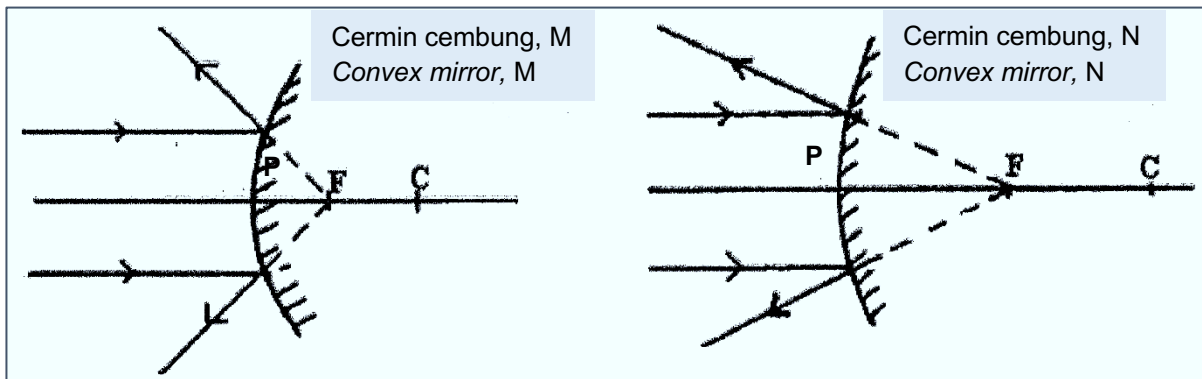

Rajah 2.1  
Diagram 2.1

Rajah 2.2  
Diagram 2.2

- (a) Apakah maksud titik fokus, F bagi sebuah cermin cembung?  
*What is the meaning of focal point, F for a convex mirror?*

[1 markah / 1 mark]

- (b) Menggunakan Rajah 2.1 dan Rajah 2.2, bandingkan kelengkungan permukaan cermin-cermin, sudut pembengkokan sinar cahaya serta panjang fokus bagi cermin-cermin itu. Hubungkan kelengkungan permukaan cermin dengan sudut pembengkokan sinar cahaya. Kemudian, hubungkan kelengkungan permukaan cermin dengan panjang fokus.  
*By using Diagram 2.1 and Diagram 2.2, compare the curvature of the surface of the mirrors, the angle of bending of light rays and the focal length of the mirrors. State the relationship between curvature of the surface with angle of bending of light rays. Then, state the relationship between curvature of the surface with focal length.*

[5 markah / 5 marks]

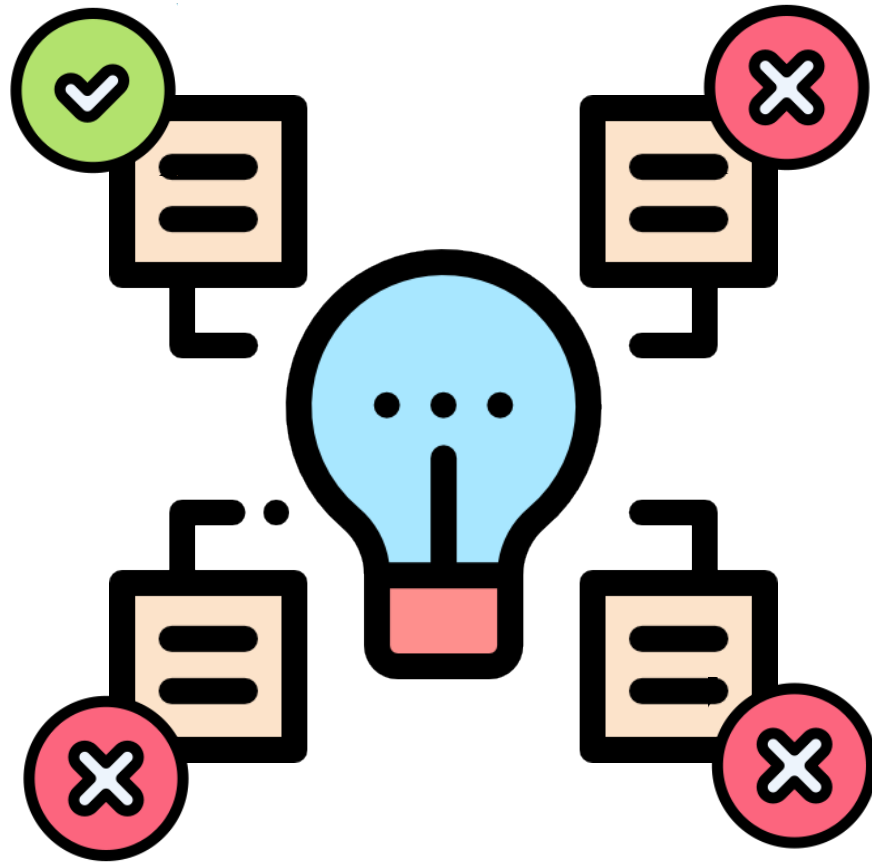

**KEMAHIRAN** : MEMBUAT KEPUTUSAN

***ELEMENT*** : *DECISION MAKING*

# BAB 1 : PENGUKURAN / CHAPTER 1 : MEASUREMENT

## BAHAGIAN B DAN C / SECTION B AND C

- 1 Empat orang pelajar iaitu P, Q, R, dan S melakukan eksperimen bagi menyiasat hubungan di antara jisim yang digantung,  $m$  dengan tempoh ayunan lengkap,  $T$ . Jadual 1 menunjukkan data yang diperolehi oleh P, Q, R, dan S.

*Four students P, Q, R, and S are conducted an experiment to investigate the relationship between the slotted mass,  $m$  and the period of one complete oscillation,  $T$ . Table 1 shows data obtained by P, Q, R, and S.*

Pelajar <i>Students</i>	Label Paksi-y <i>y-axis label</i>	Skala Paksi-x <i>x-axis scale</i>	Bilangan titik yang diplotkan dengan tepat <i>Numbers of points plotted correctly</i>	Luas graf yang dilukis di atas kertas graf <i>Size of graph drawn on graph paper</i>
A	m/kg	0.1	3	45 %
B	T	0.3	4	50 %
C	$T^2/s^2$	0.5	5	70 %
D	T/s	0.7	6	80 %

Jadual 1

*Table 1*

Berdasarkan aspek-aspek dalam Jadual 1, terangkan bagaimanakah memilih pelajar yang melukis graf yang tepat dan jitu. Nyatakan pelajar yang dipilih dan berikan sebabnya.

*Based on the aspects in Table 1, explain how to choose the student that draws the correct and accurate graph. Choose the student and state the reason.*

[10 markah / 10 marks]

**BAHAGIAN A / SECTION A**

- 1 Rajah 1.1 menunjukkan seorang lelaki di dalam kereta. Dalam suatu kemalangan, tali pinggang dalam satu kenderaan boleh membantu mengelakkan pemandu daripada tercedera.

*Diagram 1.1 shows a man inside a car. In an accident, the seat belts inside a vehicle can help to prevent the driver from being injured.*

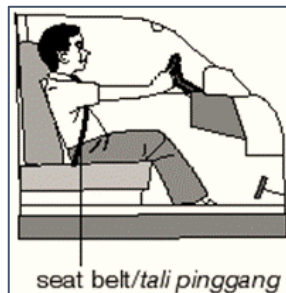

Rajah 1.1

Diagram 1.1

- (a) Guna Hukum Newton Pertama untuk menerangkan bagaimana tali pinggang boleh membantu mengelakkan pemandu daripada tercedera.

*Use Newton's First Law to explain how seat belts can help to prevent the driver from being injured.*

---

---

[2 markah / 2 marks]

- (b) Selain daripada tali pinggang, apakah ciri keselamatan lain dalam kereta yang boleh mengelakkan pemandu daripada tercedera, berdasarkan konsep fizik yang sama?

*Other than the seat belt, what is another safety feature in the car which can prevent the driver from being injured, based on the same physics concept?*

---

---

[1 markah / 1 marks]

(c) Rajah 1.2 menunjukkan dua kerusi keselamatan, K dan L dengan ciri-ciri yang berbeza.

Diagram 1.2 shows two safety car seats, K and L with different specifications.

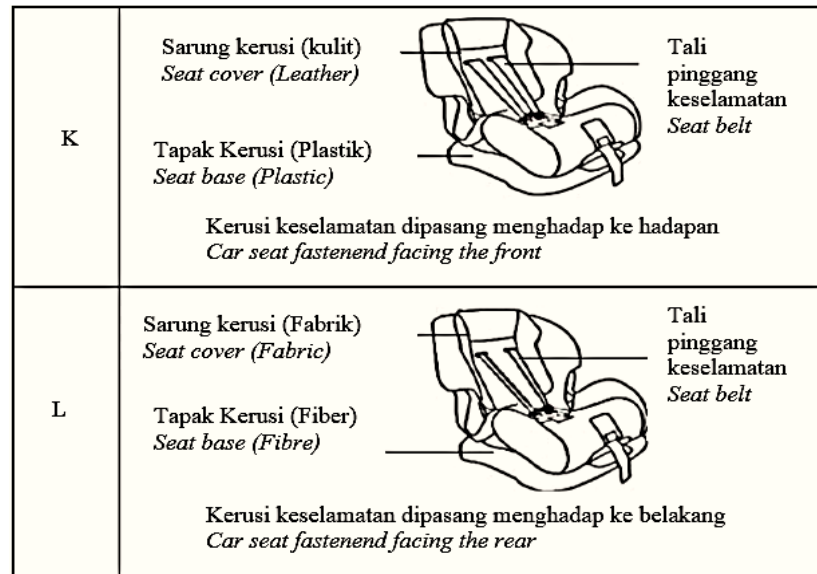

Rajah 1.2

Diagram 1.2

Berdasarkan rajah di atas, nyatakan ciri-ciri yang manakah dapat menentukan kerusi keselamatan dan cara pemasangan yang paling sesuai untuk perjalanan bayi dengan selamat.

Based on diagram above, explain the suitability to determine the most suitable car seat and the way it is positioned on the front passenger seat, for babies' safe travel.

(i) Sarung kerusi

*Seat cover*

---

Sebab

*Reason*

---

[2 markah / 2 marks]

(ii) Tapak kerusi

*Seat base*

---

Sebab

*Reason*

---

[2 markah / 2 marks]

(iii) Kedudukan pemasangan kerusi

*Car seat fastened*

---

Sebab

*Reason*

---

[2 markah / 2 marks]

(d) Berdasarkan jawapan di 1(c), tentukan kerusi keselamatan manakah paling sesuai untuk perjalanan bayi yang selamat.

*Based on the answer in 1(c), determine which safety seat is the most suitable for babies' safe travel*

---

[1 markah / 1 mark]

- 2 Rajah 2.1 menunjukkan "Newton's cradle" yang terdiri daripada lima biji bola yang serupa tergantung dalam satu baris pada kerangka kayu dengan menggunakan dawai. *Diagram 2.1 shows "Newton's cradle" which consists of five identical balls suspended in a row from a wooden frame by wires.*

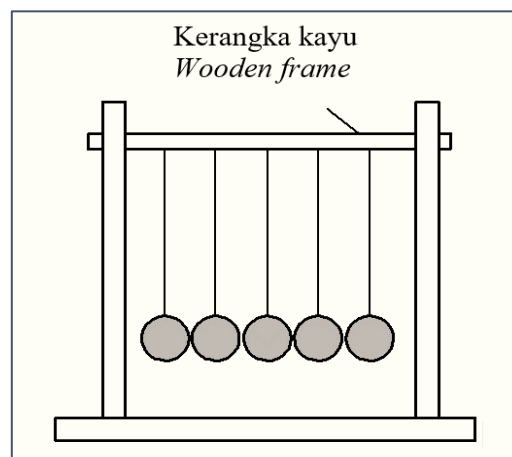

Rajah 2.1

*Diagram 2.1*

Apabila bola pada hujung kiri ditarik, Rajah 2.2 dan dijatuhkan, bola yang berada hujung satu lagi akan diketuk jauh daripada bola-bola yang lain dengan laju yang sama seperti bola yang pertama, Rajah 2.3.

*When the ball on the left end is pulled aside, Diagram 2.2 and allowed to fall, the ball on the far end is knocked away from the others with the same speed as the first ball*  
*Diagram 2.3.*

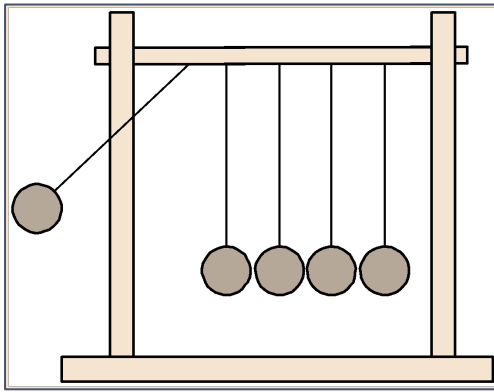

Rajah 2.2  
Diagram 2.2

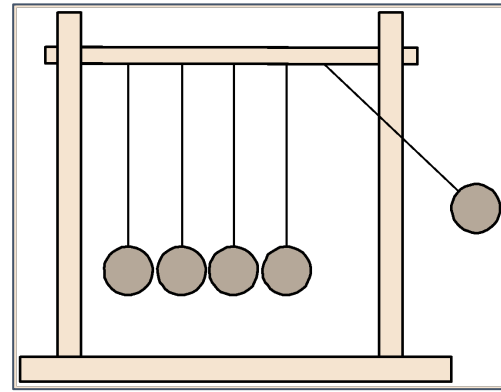

Rajah 2.3  
Diagram 2.3

- (a) Namakan prinsip fizik yang terlibat yang membuatkan bola pada hujung yang satu lagi tertolak menjauhi bola yang lain.

*Name the physics principle involved which makes the ball on the other far end knocked away from the others.*

---

[1 markah / 1 marks]

- (b) Terangkan dalam konteks momentum, mengapa bola pada hujung yang bertentangan tertolak menjauhi bola yang lain.

*Explain in terms of momentum,, why the ball on the opposite end is knocked away from the others.*

---

[2 markah / 2 marks]

- (c) Rajah 2.4 menunjukkan tiga reka bentuk "Newton's cradle", P, Q, dan R dengan spesifikasi yang berbeza.

*Diagram 2.4 shows five designs of "Newton's Cradle", P, Q, R, S and T, with different specifications.*

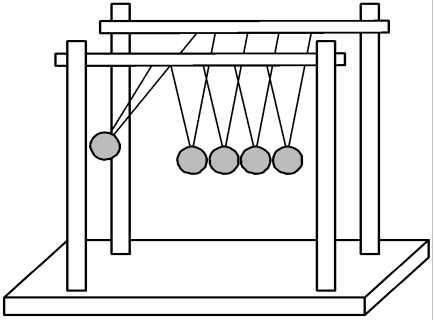
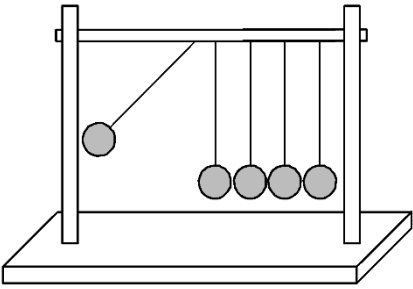
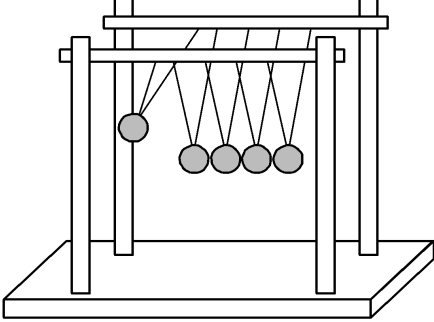
<p>Newton's Cradle P</p> <p>Bebola getah</p> <p><i>Steel balls</i></p>	
<p>Newton's Cradle Q</p> <p>Bebola keluli</p> <p><i>Steel balls</i></p>	
<p>Newton's Cradle R</p> <p>Bebola getah</p> <p><i>Rubber balls</i></p>	

Rajah 2.4

Diagram 2.4

Anda dikehendaki menentukan reka bentuk yang paling sesuai digunakan untuk menghasilkan ayunan bola pada setiap hujung lebih tinggi dan lebih laju.

Kaji ketiga-tiga rekabentuk itu dari aspek berikut:

*You are required to determine the most suitable design to make the ball at the end swing up to a higher level and at a bigger speed. Study all the three designs from the following aspects:*

- (i) Jenis bahan yang digunakan untuk membuat bebola:

*The type of material used to make the balls:*

---

Sebab:

*Reason:*

---

[2 markah / 2 marks]

(ii) Bilangan tali yang digunakan untuk menggantung bebola:

*The number of strings used to hang the balls:*

Sebab:

*Reason:*

[2 markah / 2 marks]

(d) Berdasarkan jawapan di 2(c), tentukan rekabentuk manakah paling sesuai.

*Based on the answer in 2(c), determine which design is the most suitable.*

[1 markah / 1 mark]

### BAHAGIAN B DAN C / SECTION B AND C

1 Rajah 1 menunjukkan empat lori tangki P, Q, R dan S dengan spesifikasi yang berbeza.

*Diagram below shows four tankers P, Q, R and S with different specifications.*

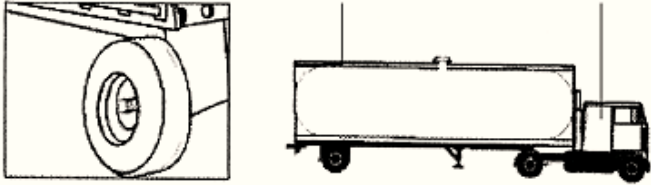
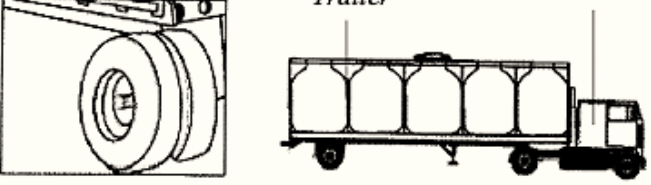
<p>Lori tangki P <i>Tanker P</i></p> <p>Jenis Brek: Udara <i>Type of brake: Air</i></p>	 <p>Treler <i>Trailer</i></p> <p>Kepala lori <i>Tractor</i></p> <p>1 tangki besar <i>1 big tank</i></p> <p>1 tayar <i>1 tyre</i></p>
<p>Lori tangki Q <i>Tanker Q</i></p> <p>Jenis Brek: Udara <i>Type of brake: Air</i></p>	 <p>Treler <i>Trailer</i></p> <p>Kepala lori <i>Tractor</i></p> <p>5 tangki besar <i>5 big tanks</i></p> <p>2 tayar <i>2 tyres</i></p>

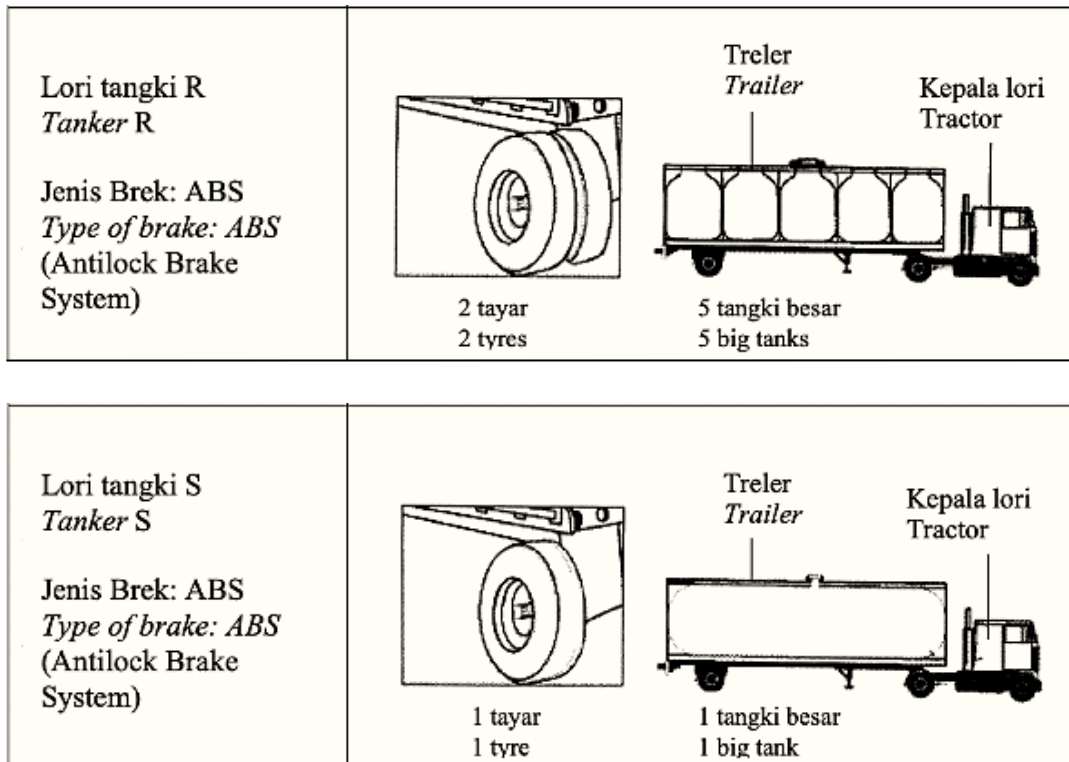

Rajah 1  
*Diagram 1*

Anda dikehendaki untuk menentukan lori tangki yang paling sesuai digunakan untuk menghantar minyak dengan selamat.

Kaji spesifikasi keempat-empat lori itu dari aspek berikut:

*You are required to determine the most suitable tanker to deliver oil safely.*

*Study the specifications of all the four tankers from the following aspects:*

- (i) Jenis brek  
*The type of brakes*
- (ii) Bilangan tayar  
*The number of tyres*
- (iii) Bilangan dan saiz tangki  
*The number and size of the tanks*
- (iv) Jarak antara treler dan kepala lori  
*The distance between the trailer and the tractor*

Terangkan kesesuaian aspek-aspek itu. Berikan sebab bagi pilihan anda.

*Explain the suitability of the aspects. Justify your choice.*

[10 markah / 10 marks]

- 2 Dalam satu pertandingan lumba kereta, empat buah kereta A, B, C dan D telah mengambil bahagian. Maklumat empat buah kereta itu diberikan dalam Jadual 2. Anda dikehendaki untuk mengkaji ciri-ciri kereta lumba dalam Jadual 2. Terangkan kesesuaian setiap ciri-ciri kereta dalam Jadual 2 dan tentukan kereta yang paling sesuai digunakan sebagai kereta lumba. Berikan sebab pilihan anda.

*In a car racing competition, four cars A, B, C and D took part.*

*The information of the four cars is given in Table 2.*

*You are asked to study the characteristics of the cars in Table 2.*

*Explain the suitability of each characteristic in Table 2 and hence, determine which car is the most suitable to be used as a racing car. Justify your choice.*

Ciri-ciri / Characteristics Kereta / Cars	Jisim/ kg Mass / kg	Masa tindak balas / s Reaction time / s	Jarak masa brek ditekan / m Braking distance / m	Jenis tayar Type of tyre
A	800	6	15	Berbunga With tread pattern
B	1 000	5	12	Berbunga With tread pattern
C	1 200	4	10	Tanpa bunga Without tread pattern
D	1500	5	10	Tanpa bunga Without tread pattern

Jadual 2

Table 2

[10 markah / 10 marks]

## BAB 3 : KEGRAVITIAN / CHAPTER 3 : GRAVITATION

### BAHAGIAN B DAN C / SECTION B AND C

- 1 Bayangkan satu situasi di mana kerajaan Malaysia ingin menghantar sebuah satelit untuk mengorbit Bumi. Fungsi satelit tersebut adalah untuk memperoleh bacaan pola cuaca yang lebih baik untuk membantu Jabatan Meteorologi Malaysia untuk membuat ramalan cuaca yang lebih tepat. Jadual di bawah menunjukkan ciri-ciri 4 model satelit, A, B, C, dan D yang mempunyai spesifikasi yang berbeza.

*Imagine a situation where the Malaysian government wants to send up a satellite to orbit the Earth. The satellite's function is to obtain a better reading of weather patterns in order to help the Malaysia Meteorological Department to make more accurate weather forecasts. The table below shows the characteristics of four satellite models, A, B, C and D with different specifications.*

Satelit Satellite	Kedudukan geografi satelit di permukaan Bumi <i>Geographical position of satellite above Earth</i>	Tempoh orbit satelit <i>Orbital period of satellite</i>	Arah orbit satelit <i>Direction of satellite orbit</i>	Orbit satelit <i>Orbit of the satellite</i>
A	Sentiasa di Malaysia <i>Always at Malaysia</i>	24 jam <i>24 hours</i>	Berbeza daripada putaran Bumi <i>Different than Earth's rotation</i>	Pada Orbit Bumi Geopegun <i>On the Geostationary Earth Orbit</i>
B	Lokasi berubah pada masa yang berlainan <i>Different locations at different times</i>	Lebih kecil dari 24 jam <i>Shorter than 24 hours</i>	Berbeza daripada putaran Bumi <i>Different than Earth's rotation</i>	Lebih tinggi daripada Orbit Bumi Geopegun <i>Lower than the Geostationary Earth Orbit</i>
C	Lokasi berubah pada masa yang berlainan <i>Different locations at different times</i>	24 jam <i>24 hours</i>	Same as Earth's rotation <i>Sama seperti putaran Bumi</i>	Lebih rendah daripada Orbit Bumi Geopegun <i>Lower than the Geostationary Earth Orbit</i>
D	Sentiasa di Malaysia <i>Always at Malaysia</i>	Lebih kecil dari 24 jam <i>Shorter than 24 hours</i>	Same as Earth's rotation <i>Sama seperti putaran Bumi</i>	Pada Orbit Bumi Geopegun <i>On the Geostationary Earth Orbit</i>

Tentukan model satelit yang paling sesuai. Jelaskan jawapan anda.

*Determine the most suitable model of the satellite. Justify your answer.*

[10 markah / 10 marks]

- 2 Anda sebagai seorang jurutera dikehendaki untuk membina sebuah satelit yang paling sesuai digunakan oleh sebuah syarikat yang menyediakan perkhidmatan siaran langsung dari seluruh dunia.

Kaji sistem satelit di bawah. Terangkan kesesuaian setiap ciri sistem satelit itu dan tentukan sistem satelit yang paling sesuai digunakan oleh syarikat tersebut.

*You as an engineer are required to build a satellite that is most suitable for use by a company that provides live broadcast services from around the world.*

*Study the satellite system below. Explain the suitability of each feature of the satellite system and determine the most suitable satellite system to be used by the company.*

<b>Sistem satelit</b> <b>Satellite system</b>	<b>Tempoh orbit</b> <b>Orbital period</b>	<b>Arah edaran</b> <b>Direction of orbit</b>	<b>Bilangan satelit</b> <b>Number of satellites</b>
W	12 jam 12 hours	Timur ke Barat From East to West	1
X	24 jam 24 hours	Barat ke Timur From West to East	3
Y	12 jam 12 hours	Utara ke Selatan From North to South	1
Z	24 jam 24 hours	Selatan ke Utara From South to North	3

[10 markah / 10 marks]

## BAB 4 : HABA / CHAPTER 4 : HEAT

### BAHAGIAN A / SECTION A

1 Rajah 1 menunjukkan satu kelalang termos.

*Diagram 1 shows a thermos flask.*

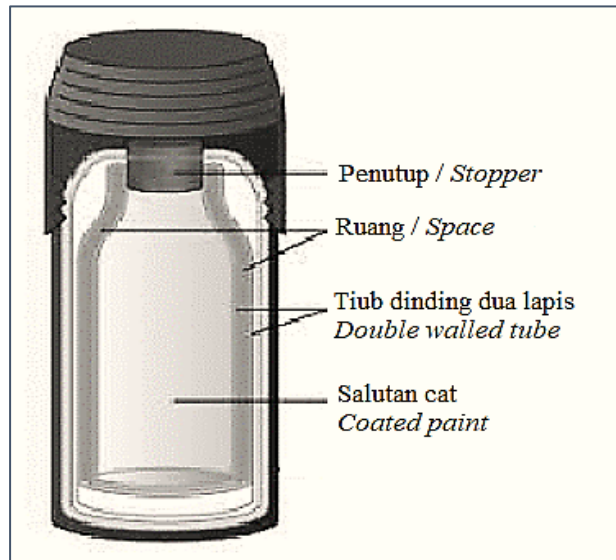

Rajah 1

*Diagram 1*

Jadual 1 menunjukkan tiga jenis kelalang termos dan ciri-cirinya.

*Table 1 shows three types of thermos flask and their characteristics.*

Kelalang termos <i>Thermos flask</i>	Penutup <i>Stopper</i>	Tiub dinding dua lapis <i>Double walled tube</i>	Ruang di antara dinding berlapis <i>Space between double wall</i>
P	Plastik pepejal <i>Solid plastic</i>	Kuprum <i>Copper</i>	Vakum <i>Vacuum</i>
Q	Plastik berongga <i>Hollow plastic</i>	Kaca <i>Glass</i>	Vakum <i>Vacuum</i>
R	Plastik berongga <i>Hollow plastic</i>	Kaca <i>Glass</i>	Udara <i>Air</i>

Jadual 1

*Table 1*

- (a) Berdasarkan jadual, nyatakan ciri-ciri bagi kelalang termos jika digunakan untuk mengekalkan minuman panas dalam tempoh yang panjang. Beri sebab bagi kesesuaian ciri-ciri tersebut.

*Based on table, state suitable characteristics of the thermos flask if it is to be used to maintain the temperature of hot drink for a long time. Give reason for the suitability of the characteristics.*

- (i) Penutup:

*Stopper:*

---

*Sebab:*

*Reason:*

---

[2 markah / 2 marks]

- (ii) Tiub dinding dua lapis:

*Double walled tube:*

---

*Sebab:*

*Reason:*

---

[2 markah / 2 marks]

- (iii) Ruang di antara dinding berlapis:

*Space between double wall:*

---

*Sebab:*

*Reason:*

---

[2 markah / 2 marks]

- (b) Berdasarkan jawapan di 1(a), tentukan kelalang termos manakah paling sesuai untuk mengekalkan suhu minuman panas dalam tempoh masa yang panjang.

*Based on the answer in 1(a), determine which thermos flask is the most suitable to maintain temperature of a hot drink for a long time.*

---

[1 markah / 1 mark]

- 2 Seorang penjaja bercadang untuk membeli sebuah periuk 'slow cooker' yang baru untuk memasak bubur. Selepas bubur dimasak, bubur akan disimpan panas untuk masa yang lama. Jadual 1 di bawah menunjukkan ciri-ciri dua jenis bekas dalam periuk 'slow cooker' yang berjisim 2 kg.

*A hawker plans to buy a new slow cooker pot for cooking porridge. After the porridge is cooked, the porridge will be kept warm for a long period. Table 1 below shows the characteristics of two types of inner pot for a slow cooker with mass 2 kg.*

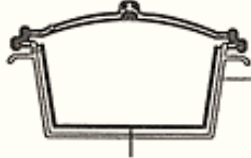
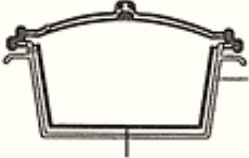
	P	Q
Bekas dalam <i>Inner pot</i>	 <p>Bekas dalam (seramik) <i>Inner pot (ceramic)</i></p>	 <p>Bekas dalam (kaca) <i>Inner pot (glass)</i></p>
Kuasa / <i>Power</i>	180W	70W
Perubahan suhu bekas dalam <i>Temperature change of inner pot</i>	60°C	60°C
Masa untuk perubahan suhu <i>Time for temperature change</i>	10 min	15 min

Jadual 2

Table 2

- (a) Hitungkan muatan haba tentu bagi bekas dalam untuk setiap 'slow cooker'.  
*Calculate the specific heat capacity of the inner pot for each slow cooker.*

[2 markah / 2 marks]

- (b) Berdasarkan jawapan di 2(a), bekas dalam periuk manakah yang paling sesuai?

*Based on the answer in 2(a), which inner pot is the most suitable?*

Sebab:

Reason:

[2 markah / 2 marks]

## BAHAGIAN B DAN C / SECTION B AND C

- 1 Jadual 1 menunjukkan ciri-ciri empat sistem penyejukan A, B, C dan D yang mengandungi agen penyejuk yang mengalir melalui paip pengalir untuk digunakan dalam penyimpanan sejuk bagi buah-buahan. Anda dikehendaki menentukan sistem penyejukan yang paling sesuai untuk menyejukkan buah-buahan dengan lebih cepat. *Table 1 shows the characteristics of four cooling systems, A, B, C and D which consist of a cooling agent that flows through a conducting pipe to be used in cold storage for fruits. You are required to determine the most suitable cooling system that can cool the fruits faster.*

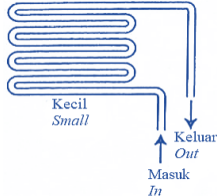
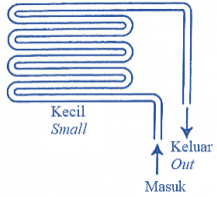
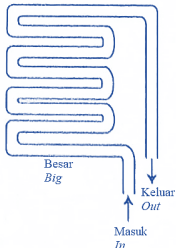
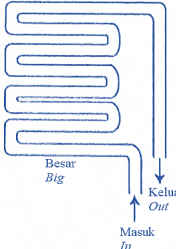
Sistem penyejukan <i>Cooling system</i>	Agen penyejuk <i>Cooling agent</i>		Paip pengalir <i>Conducting pipe</i>	
	Haba pendam tentu pengewapan <i>Specific latent heat of vaporisation</i>	Takat didih <i>Boiling point</i>	Diameter <i>Diameter</i>	Muatan haba tentu <i>Specific heat capacity</i>
A	Rendah <i>Low</i>	– 60		Tinggi <i>High</i>
B	Tinggi <i>High</i>	80		Tinggi <i>High</i>
C	Tinggi <i>High</i>	100		Rendah <i>Low</i>
D	Rendah <i>Low</i>	– 32		Rendah <i>Low</i>

Jadual 1

Table 1

Kaji spesifikasi keempat-empat reka bentuk, terangkan kesesuaian ciri-ciri untuk sistem penyejukan dan seterusnya tentukan reka bentuk yang paling sesuai. Beri sebab untuk pilihan anda.

*Study all the specifications, explain the suitability of their characteristics for a cooling system and then determine the most suitable design. Give reasons for your choice.*

[10 markah / 10 marks]

**2** Pemanas air solar menerima tenaga daripada Matahari untuk memanaskan air di dalam tangki penyimpanan. Jadual 2 menunjukkan empat reka bentuk pemanas solar bumbung P, Q, R dan S dengan spesifikasi yang berbeza.

*A solar system heater receives energy from the sun to heat up the water in its storage tank. Table 2 shows four roof solar system designs P, Q, R and S with different specifications.*

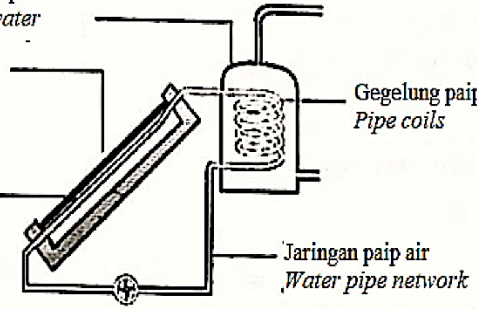
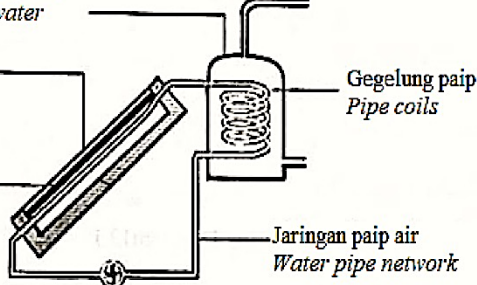
Pemanas solar Solar heater	Reka bentuk Design	Muatan haba tentu paip air Specific heat capacity of water pipe ( $\text{J kg}^{-1} \text{ }^\circ\text{C}^{-1}$ )
P	<p>Tangki penyimpanan air panas Storage tank for hot water</p> <p>Tanpa penutup kaca Without glass cover</p> <p>Panel hitam Black panel</p>  <p>Gegelung paip Pipe coils</p> <p>Jaringan paip air Water pipe network</p>	880
Q	<p>Tangki penyimpanan air panas Storage tank for hot water</p> <p>Penutup kaca Glass cover</p> <p>Panel hitam Black panel</p>  <p>Gegelung paip Pipe coils</p> <p>Jaringan paip air Water pipe network</p>	370

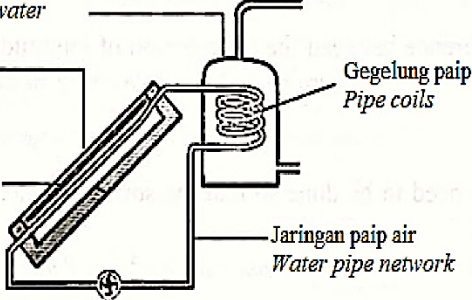
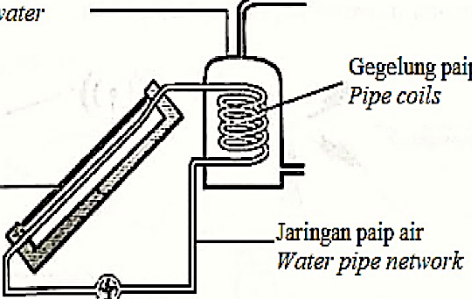
R	<p>Tangki penyimpanan air panas <i>Storage tank for hot water</i></p> <p>Penutup kaca <i>Glass cover</i></p> <p>Panel berkilat <i>Shiny panel</i></p>  <p>Gegelung paip <i>Pipe coils</i></p> <p>Jaringan paip air <i>Water pipe network</i></p>	127
S	<p>Tangki penyimpanan air panas <i>Storage tank for hot water</i></p> <p>Tanpa penutup kaca <i>Without glass cover</i></p> <p>Panel berkilat <i>Shiny panel</i></p>  <p>Gegelung paip <i>Pipe coils</i></p> <p>Jaringan paip air <i>Water pipe network</i></p>	557

Jadual 2

Table 2

Kaji spesifikasi keempat-empat reka bentuk, terangkan kesesuaian ciri-ciri untuk sistem pemanas air dan seterusnya tentukan reka bentuk yang paling sesuai. Beri sebab untuk pilihan anda.

*Study all the specifications, explain the suitability of their characteristics for a water heater system and then determine the most suitable design. Give reasons for your choice.*

[10 markah / 10 marks]

## BAB 5 : GELOMBANG / CHAPTER 5 : WAVES

### BAHAGIAN A / SECTION A

- 1 Seorang pembantu perubatan menggunakan pengimejan gema untuk mengambil gambar seorang pesakit yang menghadapi sakit hati. Kualiti gambar adalah bergantung kepada ciri-ciri gelombang yang digunakan. Jadual 1 menunjukkan 5 jenis gelombang yang boleh digunakan.

*A medical technician is using echo imaging to take a photograph of patient who is suffering from liver problem. The quality of the photograph is depending on the properties of the waves used. Table 1 shows 5 types of waves that can be used.*

Choice Pilihan	Jenis gelombang Types of waves	Panjang Gelombang Wavelength	Amplitud Amplitude	Prinsip yang Digunakan Principle used
A	Sinar X X-ray	Pendek Short	Tinggi High	Interferens Interference
B	Intrasonik Intrasonic	Panjang Long	Rendah Low	Pantulan Reflection
C	Ultrasonik Ultrasonic	Pendek Short	Tinggi High	Pantulan Reflection
D	Sinar X X-ray	Pendek Short	Rendah Low	Pembiasan Refraction
E	Ultrasonik Ultrasonic	Panjang Long	Tinggi High	Pembelauan Diffraction

Jadual 1

Table 1

Terangkan ciri-ciri gelombang yang diperlukan menghasilkan sekeping gambar yang berkualiti. Tentukan gelombang yang paling sesuai dan berikan alasan bagi pilihan anda.

*Explain the properties of the waves needed to produce a photograph with high quality.*

- (a) Jenis gelombang:  
Type of waves:

---

Sebab:

Reason:

---

[2 markah / 2 marks]

(b) Panjang gelombang:

*Wavelength:*

---

Sebab:

*Reason:*

---

[2 markah / 2 marks]

(c) Amplitud:

*Amplitude:*

---

Sebab:

*Reason:*

---

[2 markah / 2 marks]

(d) Prinsip yang digunakan:

*Principle used:*

---

Sebab:

*Reason:*

---

[2 markah / 2 marks]

(e) Berdasarkan jawapan anda di 1(a), (b), (c) dan (d), gelombang manakah yang sesuai?

*Based on your answers to 1(a), (b), (c) and (d), which setting of the speakers is suitable?*

---

[1 markah / 1 mark]

**2** Rajah 2 menunjukkan sebuah dewan kuliah di sebuah universiti. Pelajar menyatakan bahawa penambahbaikan perlu dilakukan kepada sistem bunyi.  
*Diagram 2 shows a lecture hall at a university. Students suggest that some improvements need to be made to the sound system.*

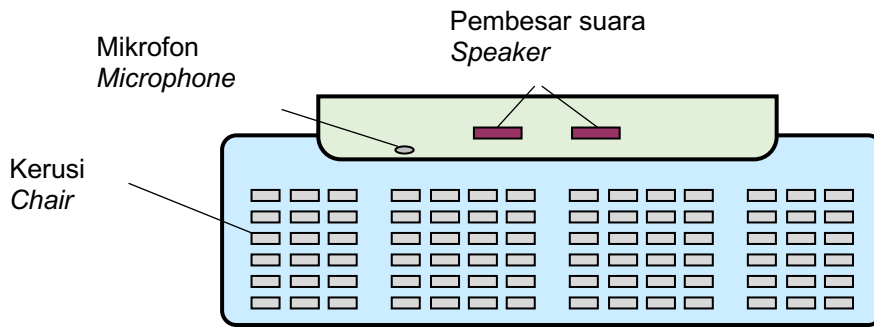

Rajah 2

Diagram 2

Jadual 2 menunjukkan empat susunan pembesar suara untuk menambahbaik sistem bunyi dewan itu.

Table 2 shows four settings of the speakers to improve the sound system in the hall.

Susunan pembesar suara <i>Settings of the speakers</i>	Kedudukan pembesar suara <i>Position of the speaker</i>	Jarak antara pembesar suara <i>Distance between the speakers</i>
P	Di hadapan mikrofon <i>In front of the microphones</i>	Dekat dengan satu sama lain <i>Close to each other</i>
Q	Di belakang mikrofon <i>Behind the microphones</i>	Dekat dengan satu sama lain <i>Close to each other</i>
R	Di belakang mikrofon <i>Behind the microphones</i>	Jauh daripada satu sama lain <i>Further from each other</i>
S	Di hadapan mikrofon <i>In front of the microphones</i>	Jauh daripada satu sama lain <i>Further from each other</i>

Jadual 2

Table 2

Cadangkan susunan pembesar suara yang sesuai supaya bunyi yang jelas dapat didengar pada keseluruhan dewan.

*Suggest a suitable setting of the speakers so that sound can be heard clearly throughout the hall.*

- (a) Kedudukan pembesar suara yang manakah sesuai?

*Which position of the speakers is suitable?*

Sebab:

Reason:

[2 markah / 2 marks]

- (b) Jarak antara pembesar suara yang manakah sesuai?  
Which distance between the speakers is suitable?

Sebab  
Reason

[2 markah / 2 marks]

- (c) Berdasarkan jawapan anda di 2(a)(i) dan 1(a)(ii), susunan pembesar suara manakah yang sesuai?  
Based on your answers to 2(a)(i) and 2(a)(ii), which setting of the speakers is suitable?

[1 markah / 1 mark]

- 3 Rajah 3 bawah menunjukkan jenis telefon bimbit di pasaran. Operasi telefon bimbit memerlukan sejenis gelombang untuk memancar dan menerima isyarat.  
Diagram 3 shows the different types of mobile phones available. The operation of the mobile phones needs a certain type of wave for transmitting and receiving signals.



Rajah 3

Diagram 3

Gelombang elektromagnet Electromagnetic waves	Jenis gelombang Type of waves	Kelajuan( $\text{ms}^{-1}$ ) Speed ( $\text{ms}^{-1}$ )	Kesan kepada pengguna Effect to user
P	Bunyi Sound	300	Tidak bahaya Not harmful
Q	Sinar inframerah Infrared rays	$3.0 \times 10^8$	Tidak bahaya Not harmful
R	Gelombang mikro Microwaves	$3.0 \times 10^8$	Tidak bahaya Not harmful
S	Sinar gama Gamma rays	$3.0 \times 10^8$	Bahaya Harmful

Jadual 3

Table 3

Anda ditugaskan untuk mengkaji dan memilih ciri-ciri gelombang dalam Jadual 3 untuk digunakan dalam telefon bimbit.

*You are assigned to study and choose the characteristics of waves in the Table 3 to be used in a mobile phone.*

(a) Jenis gelombang:

*Type of waves:*

---

Sebab:

*Reason:*

---

[2 markah / 2 marks]

(b) Kelajuan ( $\text{ms}^{-1}$ ):

*Speed ( $\text{ms}^{-1}$ ):*

---

Sebab:

*Reason:*

---

[2 markah / 2 marks]

(c) Kesan kepada pengguna:

*Effect to user:*

---

Sebab:

*Reason:*

---

[2 markah / 2 marks]

(d) Tentukan gelombang yang paling sesuai digunakan untuk telekomunikasi.

*Determine which wave is most suitable to be used as a wave for telecommunication.*

---

[1 markah / 1 mark]

## BAHAGIAN B DAN C / SECTION B AND C

1

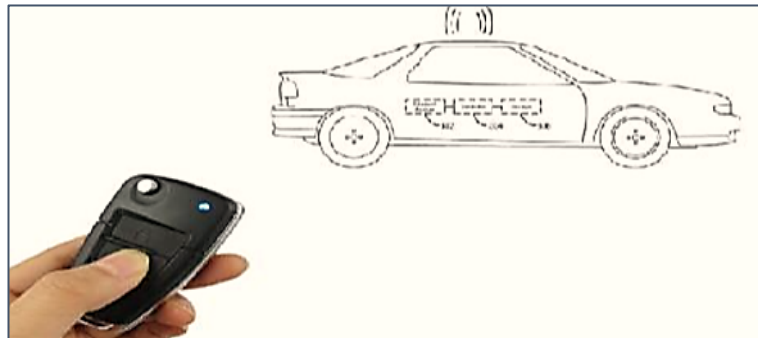

Rajah 1

*Diagram 1*

Rajah 1 menunjukkan kunci kereta automatik yang digunakan di dalam 'transmitter door lock' atau TDL. Sistem ini membolehkan keempat-empat pintu kereta dibuka secara serentak dan dikunci semula dengan satu butang sahaja. Jadual 1 menunjukkan empat jenis sistem pengesanan kunci kereta automatic K, L, M dan N.

*Diagram 1 shows an automatic car key used in the 'transmitter door lock' or TDL. The system enables to unlock all four doors of the vehicle and unlock it again with one button. Table 1 shows the four different types of automatic key detecting system uses in car K, L, M and N.*

Sistem Pengesan Detecting System	K	L	M	N
Jenis Sinar Type of ray	Sinar inframerah <i>Infrared ray</i>	Sinar Gamma <i>Gamma ray</i>	Sinar Ultraungu <i>Ultraviolet</i>	Gelombang Radio <i>Radio waves</i>
Jarak kunci dari kereta Key distance from the car	Dekat <i>Near</i>	Dekat <i>Near</i>	Dekat <i>Near</i>	Jauh <i>Far</i>
Keselamatan kepada pengguna Safety for consumers	Selamat <i>Safe</i>	Bahaya <i>Dangerous</i>	Kurang bahaya <i>Less dangerous</i>	Tiada kesan <i>No effect</i>
Sumber gelombang Waves source	Haba <i>Heat</i>	Radioaktif <i>Radioactive</i>	Gelombang cahaya <i>Light waves</i>	Gelombang elektromagnet <i>Electromagnet waves</i>

Jadual 1

*Table 1*

Anda dikehendaki menentukan jenis gelombang yang paling sesuai digunakan dalam sistem pengesan kunci kereta automatik. Terangkan kesesuaian setiap ciri. Tentukan sistem pengesan yang paling sesuai. Berikan sebab-sebab bagi pilihan anda.

*You are required to determine the most suitable types of an automatic key detecting system in cars. Explain the suitability of each characteristic. Determine the most suitable detecting system. Give reasons for your choice.*

[10 markah / 10 marks]

- 2 Rajah 2 menunjukkan gelombang air bergerak menuju ke benteng penahan ombak dekat dengan pelabuhan

*Diagram 2 shows the water wave moves toward a retaining wall near the harbour.*

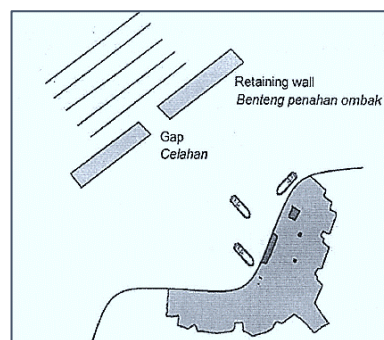

Rajah 2

*Diagram 2*

Rekabentuk dinding penahan ombak pada Rajah 2 tidak sesuai untuk melindungi pelabuhan daripada hakisan disebabkan oleh amplitud ombak yang besar.

Jadual 2 menunjukkan empat benteng penahan dengan ciri masing-masing.

*The design of the retaining wall in Diagram 2 is not suitable to protect the harbour from erosion due to high amplitude of water waves.*

*Table 2 shows four retaining walls with their respective characteristics.*

Benteng Retaining wall	Saiz celahan Size of gap	Ketinggian Height	Bahan yang digunakan Material used	Ketebalan dinding Thickness of wall
P	Kecil Small	Rendah Low	Kayu Wooden	Rendah Low
Q	Besar Large	Rendah Low	Konkrit Concrete	Tinggi High
R	Besar Large	Tinggi High	Kayu Wooden	Rendah Low
S	Kecil Small	Tinggi High	Konkrit Concrete	Tinggi High

Jadual 2

*Table 2*

Berdasarkan Jadual 2, nyatakan ciri-ciri benteng penahan ombak yang sesuai digunakan untuk melindungi pelabuhan. Tentukan benteng penahan ombak yang paling sesuai. Berikan sebab-sebab untuk pilihan anda.

*Based on Table 2, explain the characteristics of a retaining wall that is suitable to be used to protect the harbour. Determine the most suitable retaining wall. Give reasons for your choice.*

[10 markah / 10 marks]

- 3 Sebuah pelabuhan baru hendak dibina di satu lokasi yang baru. Lokasi baru dicadangkan sama ada di teluk atau di tanjung. Empat model untuk struktur binaan tembok penahan diberi.

Jadual 3 di bawah menunjukkan lokasi dan ciri-ciri bagi empat tembok penahan itu. *A new harbour is to be built at a new location. The suggested new location is either at a bay or a cape. Four models for the structure of the retaining wall are given.*

*Table 3 below shows the location and the characteristics of the four retaining walls.*

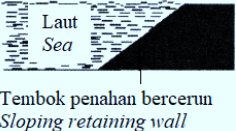
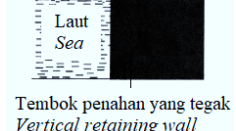
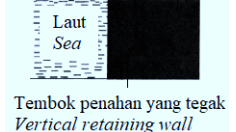
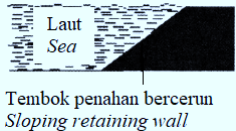
Jenis tembok penahan <i>Type of retaining wall</i>	Lokasi tembok penahan <i>Location of retaining wall</i>	Struktur tembok penahan <i>Structure of retaining wall</i>	Permukaan tembok penahan <i>Surface of retaining wall</i>	Ketinggian tembok penahan <i>Height of retaining wall</i>
W	Teluk Bay		Tidak rata <i>Uneven</i>	Tinggi <i>High</i>
X	Tanjung Cape		Rata <i>Even</i>	Tinggi <i>High</i>
Y	Teluk Bay		Rata <i>Even</i>	Rendah <i>Low</i>
Z	Tanjung Cape		Tidak rata <i>Uneven</i>	Rendah <i>Low</i>

Jadual 3

Table 3

Terangkan lokasi yang terbaik dan kesesuaian setiap ciri dalam Jadual 1. Tentukan tembok yang paling sesuai untuk digunakan. Beri sebab untuk pilihan anda.

*Explain the best location and the suitability of each characteristic in Table 1.*

*Determine the most suitable retaining wall to be used. Give reasons for your choice.*

[10 markah / 10 marks]

## BAB 6 : CAHAYA DAN OPTIK / CHAPTER 6 : LIGHT AND OPTICS

### BAHAGIAN A / SECTION A

- 1 Rajah 1.1 menunjukkan satu objek, O diletakkan di hadapan suatu kanta cembung. panjang fokus kanta ialah 6 cm.

*Diagram 1.1 shows an object, O is placed in front of a convex lens. Focal length of the lens is 6 cm.*

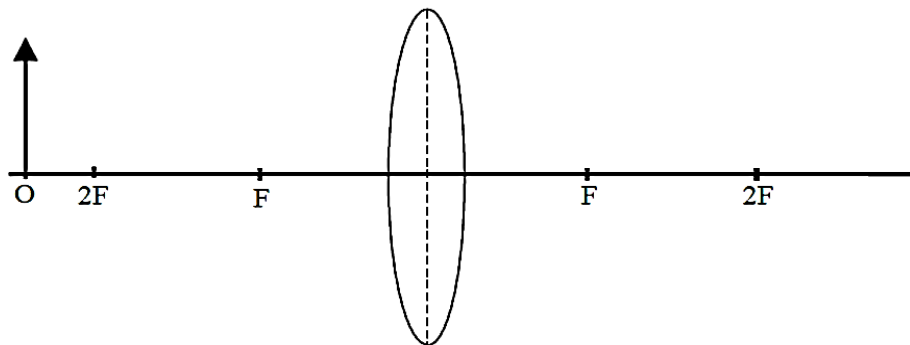

Rajah 1.1

Diagram 1.1

- (a) Apakah yang dimaksudkan dengan panjang fokus?  
*What is the meaning of focal length?*

---

[1 markah / 1 mark]

- (b) (i) Lukis rajah sinar pada Rajah 1.1 untuk menunjukkan bagaimana imej terbentuk.  
*Draw the ray diagram on Diagram 1.1 to show how the image is formed.*

[1 markah / 1 mark]

- (ii) Nyatakan dua ciri imej yang terbentuk dalam Rajah 1.1.  
*State two characteristics of the image formed in Diagram 1.1.*

---

[1 markah / 1 mark]

- (c) Rajah 1.2 menunjukkan satu teleskop astronomi  
*Diagram 1.2 shows an astronomical telescope.*

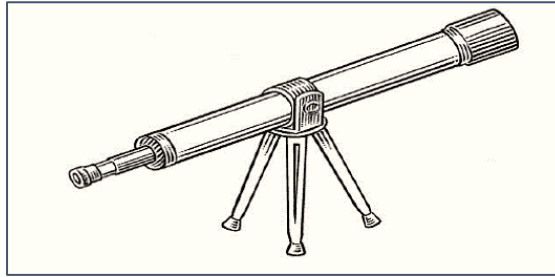

Rajah 1.2  
*Diagram 1.2*

Jadual 1 menunjukkan empat kanta yang boleh digunakan untuk membina teleskop.  
*Table 1 shows four lenses that can be used to build the telescope.*

Kanta <i>Lens</i>	Jenis Kanta <i>Type of lens</i>	Panjang focus, $f$ / cm <i>Focal length, <math>f</math> / cm</i>	Diameter kanta <i>Diameter of lens</i>
P	Cembung <i>Convex</i>	100	Besar <i>Big</i>
Q	Cembung <i>Convex</i>	25	Besar <i>Big</i>
R	Cekung <i>Concave</i>	100	Small <i>Kecil</i>
S	Concave <i>Cekung</i>	25	Small <i>Kecil</i>

Jadual 1  
*Table 1*

Berdasarkan Jadual 1, nyatakan ciri-ciri kanta yang sesuai untuk digunakan sebagai kanta objektif.

*Based on Table 1, state the suitable characteristics of the lens to be used as objective lens.*

- (i) Jenis kanta:  
*Types of lens:*

Sebab:

*Reason:*

[2 markah / 2 marks]

(ii) Panjang fokus,  $f$ :

*Focal length,  $f$ :*

Sebab:

*Reason:*

[2 markah / 2 marks]

(iii) Diameter:

*Diameter:*

Sebab:

*Reason:*

[2 markah / 2 marks]

(d) Berdasarkan jawapan anda di 1(c), pilih kanta yang paling sesuai digunakan sebagai kanta objektif.

*Based on your answers in 1(c), choose the most suitable lens to be used as an objective lens.*

[1 markah / 1 mark]

2 Rajah 2.1 dan Rajah 2.2 menunjukkan lintasan sinar cahaya yang memasuki suatu prisma kaca. Indeks biasan prisma kaca itu adalah 1.5.

*Diagram 2.1 and Diagram 2.2 show a light ray path entering a glass prism.*

*The refractive index of the glass prism is 1.5.*

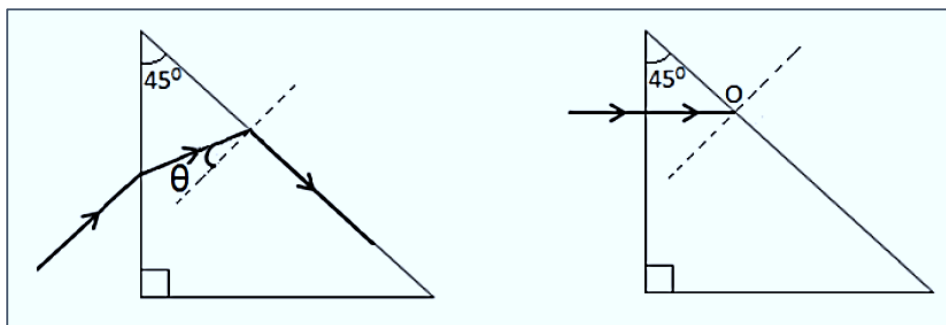

Rajah 2.1

*Diagram 2.1*

Rajah 2.2

*Diagram 2.2*

(a) Berdasarkan Rajah 2.1, hitungkan sudut  $\theta$ .

*Based on Diagram 2.1, calculate angle  $\theta$ .*

$\theta =$  \_\_\_\_\_  $^{\circ}$

[2 markah / 2 marks]

(b) (i) Pada Rajah 2.2, lengkapkan lintasan sinar cahaya dari titik O.

*In Diagram 2.2, complete the light ray path from point O.*

[1 markah / 1 mark]

(ii) Berdasarkan jawapan di 2(b)(i), namakan fenomena cahaya yang terlibat.

*Based on the answer in 2(b)(i), name the light phenomenon involved.*

\_\_\_\_\_ [1 markah / 1 mark]

(c) Rajah 2.3 menunjukkan keratan rentas sebuah periskop ringkas.

*Diagram 2.3 shows a cross section of a simple periscope.*

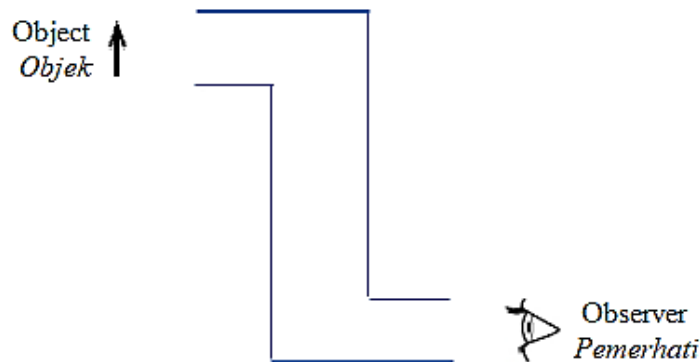

Rajah 2.3  
Diagram 2.3

Pada Rajah 3.3, lukis kedudukan prisma-prisma di dalam periskop tersebut. Kemudian, lukiskan lintasan sinar cahaya yang memasuki kedua-dua prisma itu.

*In Diagram 3.3, draw the position of the prisms in the periscope.*

*Then draw the ray path entering both prisms.*

[3 markah / 3 marks]

- (d) Jadual 2 menunjukkan ciri-ciri bagi **tiga** prisma yang boleh digunakan di dalam sebuah periskop.

*Table 2 shows the characteristics of **three** prisms that can be used in a periscope.*

<b>Prism</b> <i>Prisma</i>	<b>Refractive index</b> <i>Indeks biasan</i>	<b>Size</b> <i>Saiz</i>
P	1.52	Big <i>Besar</i>
Q	1.46	Small <i>Kecil</i>
R	1.43	Big <i>Besar</i>

Jadual 2

*Table 2*

Berdasarkan Jadual 2, nyatakan kesesuaian ciri-ciri pada prisma untuk digunakan di dalam sebuah periskop. Berikan **satu** sebab untuk kesesuaian ciri itu.

*Based on Table 2, state the suitable characteristics of the prism to be used in a periscope. Give **one** reason for the suitable characteristics.*

- (i) Indeks biasan:

*Refractive index:*

---

Sebab:

*Reason:*

---

[2 markah / 2 marks]

- (ii) Saiz:

*Size:*

---

Sebab:

*Reason:*

---

[2 markah / 2 marks]

- (e) Berdasarkan jawapan di 2(d)(i) dan 2(d)(ii), tentukan prisma yang paling sesuai digunakan di dalam sebuah periskop.

*Based on the answers in 2(d)(i) and 2(d)(ii), determine the most suitable prism to be used in a periscope.*

---

[1 markah / 1 mark]

## BAHAGIAN B DAN C / SECTION B AND C

- 1 Rajah 1 menunjukkan satu teleskop astronomi yang digunakan untuk melihat objek yang sangat jauh seperti bulan.

*Diagram 1 shows an astronomical telescope which is used to view very distant objects like moon.*

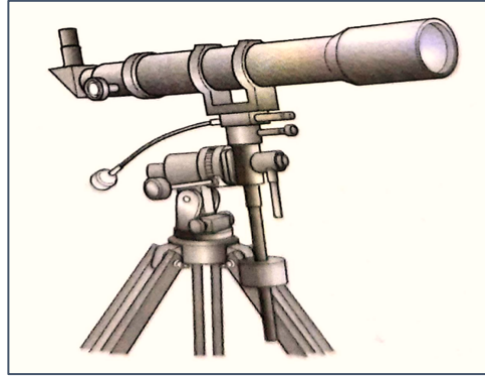

Rajah 1

*Diagram 1*

Jadual 1 menunjukkan ciri-ciri bagi empat teleskop astronomi ringkas yang berlainan.

*Table 1 show the characteristics of four different simple astronomical telescope*

Teleskop Telescope	Jenis kanta <i>Type of lens</i>	Panjang fokus kanta objektif <i>Focal length of objective lens</i>	Kuasa kanta <i>Power of Lens</i>	Diameter kanta objek <i>Diameter of objective lens</i>
P	Cembung <i>Convex</i>	40	10	5.0
Q	Cekung <i>Concave</i>	10	40	2.5
R	Cekung <i>Concave</i>	10	10	2.5
S	Cembung <i>Convex</i>	40	40	5.0

Jadual 1

*Table 1*

Terangkan bagaimana setiap ciri teleskop itu dan tentukan teleskop yang paling sesuai digunakan untuk melihat objek yang jauh. Beri sebab untuk pilihan anda.

*Explain the suitability of each characteristic of the telescope and determine the most suitable telescope to be used to observe very far object. Give reasons for your choice.*

[10 markah / 10 marks]

- 2 Jadual 2 menunjukkan spesifikasi bagi empat keping cermin melengkung J, K, L dan M yang boleh digunakan sebagai cermin cegah kecurian dalam pasar raya.

*Table 2 shows the specifications for four pieces of curved mirrors J, K, L and M that can be used as anti- theft mirrors in a supermarket.*

Cermin melengkung <i>Curved mirror</i>	Spesifikasi cermin melengkung <i>Specifications of curve mirror</i>			
	Bentuk <i>Type</i>	Berat (N) <i>Weight (N)</i>	Diameter(cm) <i>Diameter (cm)</i>	Jejari kelengkungan(cm) <i>Radius of curvature(cm)</i>
J	Cekung <i>Concave</i>	95	40	10
L	Cekung <i>Concave</i>	80	60	20
L	Cembung <i>Convex</i>	65	60	20
M	Cembung <i>Convex</i>	80	80	10

Jadual 2

*Table 2*

Terangkan kesesuaian setiap ciri cermin melengkung. Tentukan cermin melengkung yang paling sesuai untuk digunakan supaya keseluruhan bahagian dalam pasar raya kelihatan. Berikan sebab-sebab untuk pilihan anda.

*Explain the suitability of each feature of a curved mirror. Determine the most suitable curved mirror to use so that the entire interior of the supermarket is visible. Give reasons for your choice.*

[10 markah / 10 marks]

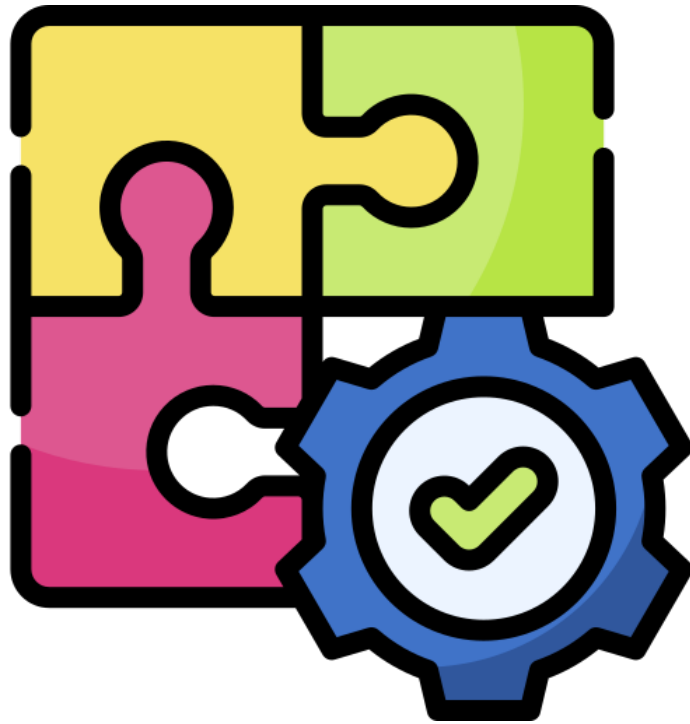

**KEMAHIRAN : MENYELESAIKAN MASALAH**

***ELEMENT : PROBLEM SOLVING***

**BAB 2 : DAYA DAN GERAKAN I / CHAPTER 2 : FORCE AND MOTION I**

**BAHAGIAN A / SECTION A**

- 1 Rajah 1 menunjukkan graf halaju-masa bagi sebuah kereta yang sedang bergerak di lebuh raya.

*Diagram 1 shows the velocity-time graph of a car travelling along the highway.*

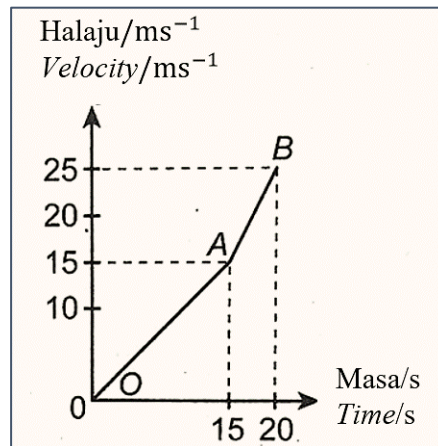

Rajah 1

Diagram 1

- (a) Tandakan ( / ) pada jawapan yang betul dalam katak yang disediakan.

*Tick ( / ) the correct answer in the box provided.*

Halaju adalah

*Velocity is a*

Kuantiti skalar <i>Scalar quantity</i>	<input type="checkbox"/>
-------------------------------------------	--------------------------

Kuantiti vektor <i>Vector quantity</i>	<input type="checkbox"/>
-------------------------------------------	--------------------------

[1 markah / 1 mark]

- (b) Berdasarkan Rajah 1;

*Based on Diagram 1;*

- (i) hitung laju pelajar pada bahagian OA dan AB.

*calculate the speed of the student at section OA and AB.*

[2 markah / 2 marks]

- (ii) bandingkan pecutan kereta itu pada OA dan AB.  
*compare the acceleration of the car at OA and AB.*

.....  
[1 markah / 1 mark]

- (c) Berdasarkan aspek berikut, beri cadangan bagaimana pecutan boleh ditambah pada kadar yang lebih tinggi.

*Based on the following aspects give suggestions on how the acceleration can be increased at a higher rate.*

- (i) Jisim kereta itu  
*Mass of the car*

.....  
Sebab  
*Reason*

.....  
[2 markah / 2 marks]

- (ii) Bentuk kereta  
*Shape of the car*

.....  
Sebab  
*Reason*

.....  
[2 markah / 2 marks]

- (iii) Kuasa enjin  
*Engine capacity*

.....  
Sebab  
*Reason*

.....  
[2 markah / 2 mark]

- 2 Rajah 2.1 di bawah menunjukkan sebuah lori balak berjirim 4000 kg. Lori balak itu membawa muatan panjang dan berat di atasnya.

*Diagram 2.1 below shows a log truck with a mass of 4000 kg. The log truck is carrying a long and heavy load on it.*

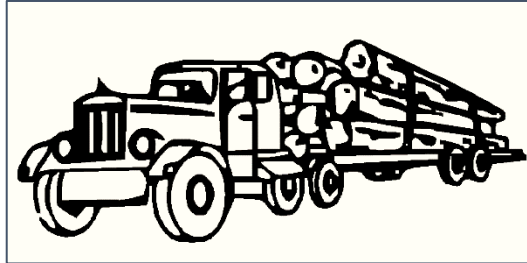

Rajah 2.1

*Diagram 2.1*

- (a) Sekiranya lori balak itu bermula dari keadaan rehat dan mencapai halaju  $40 \text{ ms}^{-1}$  dalam 20 s, hitung:

*If the log truck starts from rest and reaches a velocity of  $40 \text{ ms}^{-1}$  in 20 s, calculate:*

- (i) pecutannya  
*its acceleration*

[2 markah / 2 marks]

- (ii) daya yang bertindak ke atas lori balak itu.  
*the force acting on the log truck.*

[2 markah / 2 marks]

- (b) Lori balak dalam rajah di atas digunakan untuk mengangkut sejumlah kayu balak yang dalam jumlah yang lebih besar dengan selamat. Cadangkan pengubahsuaian yang perlu dibuat berdasarkan aspek berikut:

*The log truck in diagram above is used for transporting logs in a larger quantity safely. Suggest modifications that can be made based on the following aspects:*

(i) bilangan tayar  
*number of tyres*

.....  
sebab  
*reason*

[2 markah / 2 marks]

(ii) bilangan rantai pengikat.  
*the number of binder*

.....  
Sebab  
Reason

[2 markah / 2 marks]

(c) Rajah 2.2 di bawah menunjukkan had laju yang dipaparkan di belakang lori balak tersebut.

*Diagram 2.2 below shows the speed limit displayed on the back of the log truck.*

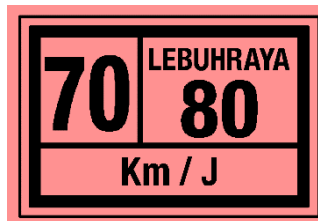

Rajah 2.2  
*Diagram 2.2*

Terangkan mengapa had laju mesti dikuatkuasakan pada kenderaan berat.

*Explain why the speed limit must be imposed on heavy vehicles.*

.....  
.....

[2 markah / 2 marks]

## BAHAGIAN B DAN C / SECTION B AND C

- 1 Rajah 1 menunjukkan sebuah roket air.

*Diagram 1 shows a water rocket.*

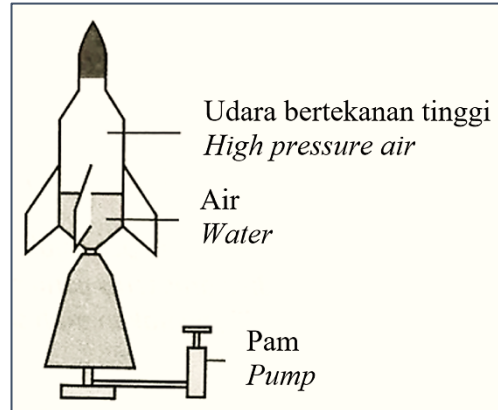

Rajah 1

*Diagram 1*

Anda dikehendaki memberi beberapa cadangan untuk mereka bentuk sebuah roket air dalam pertandingan sekolah untuk bergerak pada altitud yang lebih tinggi dan mempunyai masa yang lebih lama di udara. Menggunakan pengetahuan tentang daya dan gerakan serta sifat bahan, terangkan cadangan itu berdasarkan aspek-aspek berikut;

*You are required to give some suggestions to design a water rocket in school competition to move at higher altitude and have longer time in the air. Using the knowledge on forces and motion and the properties of materials, explain the suggestions based on the following aspects;*

- (i) ciri-ciri roket air  
*the characteristics of the water rocket*
- (ii) sudut pelancaran  
*the angle of launching*
- (iii) ciri-ciri tambahan yang membolehkan roket kekal lebih lama di udara  
*additional features that allow the rocket to stay longer in the air*

[10 markah / 10 marks]

- 2 Rajah 2 menunjukkan satu model menanam cerucuk yang digunakan pada satu tapak pembinaan bangunan. Anda dikehendaki untuk mengubah suai reka bentuk model menanam cerucuk itu supaya kerja untuk menanam cerucuk di kawasan pembinaan menjadi lebih berkesan.

*Diagram 2 shows a pile planter used in a construction site. You are required to modify a pile planter model so that the piling works in the construction site will be more efficient.*

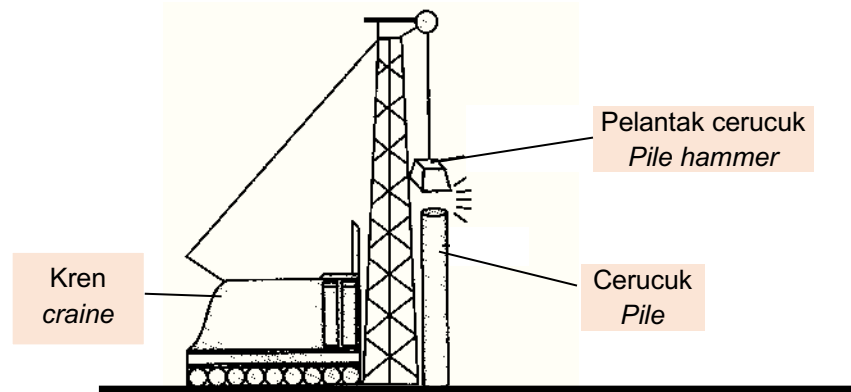

Rajah 2  
Diagram 2

Nyatakan dan terangkan pengubahsuaian berdasarkan aspek-aspek yang berikut;

*State and explain the modifications based on the following aspects;*

- (i) jisim pelantak cerucuk  
*mass of the pile hammer*
- (ii) ketinggian maksimum dari cerucuk  
*maximum height from pile*
- (iii) kekerasan pelantak cerucuk  
*hardness of pile hammer*
- (iv) kuasa enjin kren  
*engine power of crane*
- (v) bentuk cerucuk  
*shape of pile*

[10 markah /10 marks]

## BAB 3 : KEGRAVITIAN / CHAPTER 3 : GRAVITATION

### BAHAGIAN B DAN C / SECTION B AND C

- 1 Rajah 1 menunjukkan sebuah satelit yang digunakan untuk memancarkan isyarat bagi tujuan perkhidmatan telefon dan penghantaran data.

*Diagram 1 shows a satellite used to transmit signals for telephone and data transmission services.*

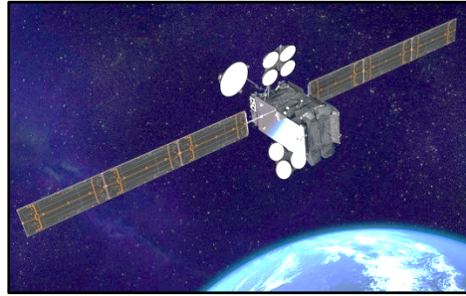

Rajah 1

*Diagram 1*

Anda telah ditugaskan untuk merekabentuk dan melancarkan sebuah satelit untuk memperoleh bacaan pola cuaca yang lebih baik untuk membantu Jabatan Meteorologi Malaysia untuk membuat ramalan cuaca yang lebih tepat.

*You have been tasked to design and launch a satellite to obtain a better reading of weather patterns in order to help the Malaysia Meteorological Department to make more accurate weather forecasts.*

Dalam penerangan anda, terangkan berdasarkan aspek-aspek berikut;

*In your explanation, elaborate on the following aspects;*

- Bahan yang digunakan untuk membina satelit  
*Materials used to build the satellite*
- Tempoh orbit satelit  
*Orbital period of satellite*
- Kedudukan geografi satelit di permukaan Bumi  
*Geographical position of satellite above Earth*
- Arah orbit satelit  
*Direction of satellite orbit*
- Orbit satelit  
*Orbit of the satellite*

[10 markah / 10 marks]

- 2 Andaikan bahawa teknologi telah berkembang jauh sehingga mencapai suatu tahap dimana manusia sudah berupaya untuk mendiami planet lain. Anda dikehendaki menghasilkan suatu reka bentuk sistem orbit bagi satelit komunikasi yang akan mengorbit planet T. Planet T mempunyai maklumat seperti berikut:

*Assume that technology has evolved to a point where humans are able to inhabit other planets. You are required to produce a design of an orbital system for communication satellites that will be orbiting planet T. Details of planet T are:*

Jisim / kg, ( <i>Mass / kg</i> )	=	$17.74 \times 10^{24}$
Jejari / m, ( <i>Radius / m</i> )	=	$4.99 \times 10^6$
Tempoh putaran / jam, ( <i>Orbital period / hour</i> )	=	96.96

Cadangkan ciri-ciri satelit dari aspek ketinggian orbit, tempoh orbit, laju linear satelit serta tapak pelancaran.

*Suggest the characteristics of the satellites in terms of orbital height, orbital duration, linear speed and launch site.*

[10 markah / 10 marks]

## BAB 4 : HABA / CHAPTER 4 : HEAT

### BAHAGIAN A / SECTION A

- 1 Rajah 1 menunjukkan satu pelapik penyejuk yang digunakan untuk menurunkan suhu seorang yang demam panas. Pelapik itu mengandungi satu gel dan disejukkan dalam peti sejuk sebelum diletakkan pada dahi orang itu untuk mengeluarkan haba.

*Diagram 1 shows a cooling pad used to lower the temperature of a person having fever. The pad consists of a gel and is cooled in a refrigerator before it is placed on the forehead of the person to remove the heat.*

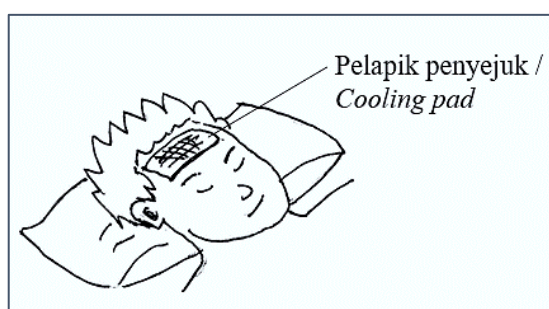

Rajah 1

Diagram 1

- (a) (i) Apakah yang dimaksudkan dengan haba?  
*What is meant by heat?*

.....

[1 markah / 1 mark]

- (ii) Jelaskan bagaimana haba dikeluarkan dari dahi orang itu.  
*Explain how the heat is removed from the forehead of the person.*

.....

.....

[2 markah / 2 marks]

- (b) Adalah dicadangkan bahawa pelapik penyejuk itu perlu diubahsuai supaya ia dapat mengeluarkan lebih banyak haba. Berikan satu sebab untuk setiap ciri.  
*It is suggested that the cooling pad should be modified so that it can remove more heat. Give one reason for each characteristic.*

(i) Saiz pelapik penyejuk

*Size of cooling pad*

.....  
Sebab

*Reason*

.....  
[2 markah / 2 marks]

(ii) Jenis gel

*Type of gel*

.....  
Sebab

*Reason*

.....  
[2 markah / 2 marks]

**2** Satu bahan pepejal berjisim 0.05 kg dipanaskan menggunakan pemanas rendam 240V, 1 kW selama 1 minit sehingga suhunya ialah 78 °C.

*A solid substance with a mass of 0.05 kg is heated using an immersion heater of 240V, 1 kW for 1 minute until its temperature is 78 °C.*

(a) (i) Apakah yang dimaksudkan dengan suhu?

*What is meant by temperature?*

.....  
[1 markah / 1 mark]

(b) Rajah 2 menunjukkan struktur sebuah kotak ais digunakan untuk menyimpan ais.

*Diagram 2 shows the structure of an ice box used to store ice.*

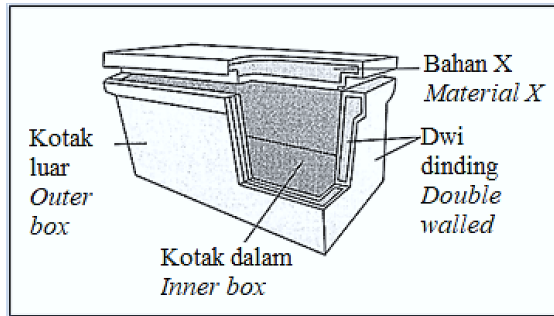

Rajah 2

Diagram 2

Nyatakan ciri-ciri kesesuaian kotak ais untuk digunakan sebagai tempat simpanan ais yang efisien. Beri satu sebab untuk setiap ciri.

*State the suitable characteristics of the ice box to be used as an efficient ice storage.*

*Give one reason for each characteristic.*

- (i) Bahan X  
*Material X*

.....

Sebab

*Reason*

.....

[2 markah / 2 marks]

- (ii) Muatan haba tentu bagi kotak dalam  
*Specific heat capacity on inner box*

.....

Sebab

*Reason*

.....

[2 markah / 2 marks]

- (iii) Ketebalan dwidinding  
*Thickness of double walled*

.....

Sebab

*Reason*

.....

[2 markah / 2 marks]

## BAHAGIAN B DAN C / SECTION B AND C

- 1 Rajah 1 menunjukkan satu termometer digunakan untuk mengukur suhu suatu cecair.  
*Diagram 1 shows a thermometer used to measure the temperature of a liquid.*

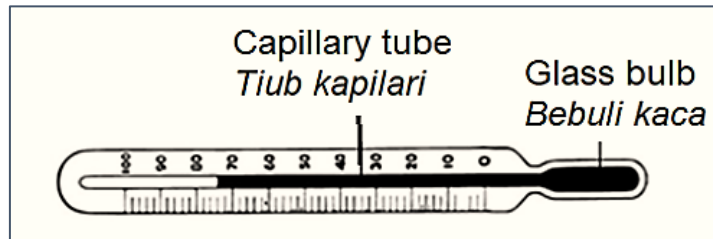

Rajah 1

*Diagram 1*

Anda dikehendaki mengubahsuai termometer itu supaya ianya lebih berkesan dan sensitif berdasarkan kepada aspek-aspek seperti:

*You are required to modify the thermometer so that it will be more effective and sensitive based on the aspects such as:*

- (i) jenis cecair yang digunakan dalam termometer  
*the type of liquid used in the thermometer*
- (ii) jenis bahan untuk binaan badan termometer  
*type of material used for the body of the thermometer*
- (iii) diameter tiub rambut  
*diameter of the capillary tube*
- (iv) bentuk keratan rentas badan termometer itu dilihat daripada pandangan atas.  
*the cross sectional shape of the thermometer's body viewed from the top*

[10 markah / 10 marks]

- 2 Rajah 2 menunjukkan sebuah pondok pada stesen keretapi di kawasan kota. Menggunakan konsep fizik yang sesuai, terangkan kegunaan bahan-bahan yang sesuai dan reka bentuk bagi memperbaiki keadaan stesen keretapi dan memastikan suhu di dalam stesen keretapi tidak terlalu tinggi pada cuaca yang panas.

*Diagram 2 shows a train station in an urban area. Using appropriate physics concepts, explain the use of suitable material and design to improve the condition of the train station and to ensure the temperature under shelter is not too high during hot weather.*



Rajah 2

Diagram 2

Jawapan anda hendaklah merangkumi aspek-aspek berikut:

*Your answer should include the following aspects:*

- (i) Jenis bahan dinding  
*Type of material for the wall*
- (ii) Bilangan dan saiz bukaan udara  
*Number and size of air holes.*
- (iii) Ciri tambahan yang boleh menyejukkan pondok tersebut.  
*Additional features that can cool the shelter.*

[10 markah / 10 marks]

# BAB 5 : GELOMBANG / CHAPTER 5 : WAVES

## BAHAGIAN A / SECTION A

- 1 Pemantul gema di atas kapal menghasilkan gelombang bunyi. Bot nelayan menggunakan pemantul gema untuk menentukan kedudukan kedalaman laut.

*An echo – sounder on a ship produces a pulse of sound. A fishing boat uses the sound echo to determine the depth of seabed.*

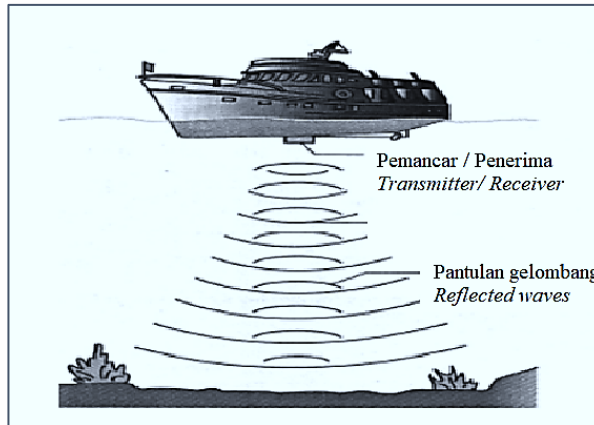

Rajah 1

Diagram 1

Anda ditugaskan untuk menyelidik ciri-ciri gelombang yang sesuai digunakan untuk menentukan kedalaman dasar laut.

*You are assigned to investigate the suitable characteristics of the waves that could be used to determine the depth the seabed.*

Berikan cadangan dan sebab anda untuk

*Give your suggestions and reason for*

- (a) Jenis gelombang yang digunakan

*Type of waves used*

.....

Sebab

*Reason*

.....

[2 markah / 2 marks]

(b) Frekuensi gelombang yang digunakan

*Frequency of waves used*

.....

Sebab

*Reason*

.....

[2 markah / 2 marks]

(c) Kelajuan gelombang yang digunakan

*Speed of waves used*

.....

Sebab

*Reason*

.....

[2 markah / 2 marks]

(d) Kuasa penembusan gelombang yang digunakan

*Penetrating power of waves used*

.....

Sebab

*Reason*

.....

[2 markah / 2 marks]

**2** Rajah 2 menunjukkan sebuah kampung berhampiran pantai yang berteluk dan bertanjung. Semasa musim tengkujuh, saiz ombak adalah besar. Ombak besar telah menyebabkan hakisan pantai, keruntuhan jeti dan kerosakan bot penduduk tempatan.

*Diagram 2 shows a village near a beach with bay and cape. During rainy season, waves are big. The waves eroded the seashore, caused the jetty to collapse and damage the boats.*



Rajah 2

Diagram 2

Bagi mengelakkan kerosakan serupa berulang para penduduk bercadang untuk membina benteng dan memindahkan jeti ke tempat baru. Berdasarkan situasi tersebut, berikan cadangan untuk mengatasi masalah penduduk dengan menggunakan aspek-aspek berikut dan jelaskan sebabnya

*To prevent similar damage in future, the villagers suggest building retaining walls and relocating the jetty. Based on the situation, make suggestions of ways to help the villagers by using the following aspects and give your reason.*

(a) Struktur benteng

*Structure of retaining wall*

.....

Sebab

*Reason*

.....

[2 markah / 2 marks]

(b) Pintu masuk

*Gap design*

.....

Sebab

*Reason*

.....

[2 markah / 2 marks]

- (c) Lokasi baru jeti  
*The location of new jetty*

.....

Sebab

*Reason*

.....

[2 markah / 2 marks]

### BAHAGIAN B DAN C / SECTION B AND C

- 1 Rajah 1 menunjukkan pantai bagi satu kampung nelayan. Semasa musim tengkujuh, saiz gelombang adalah besar. Pada suatu tahun gelombang ini menghakis pantai meruntuhkan jeti dan merosakkan bot-bot nelayan.

*Diagram 1 shows the seashore of a fishing village. During the rainy season, waves are big. One year the waves eroded the seashore, caused the jetty to collapse and damage the fishermen's boats.*

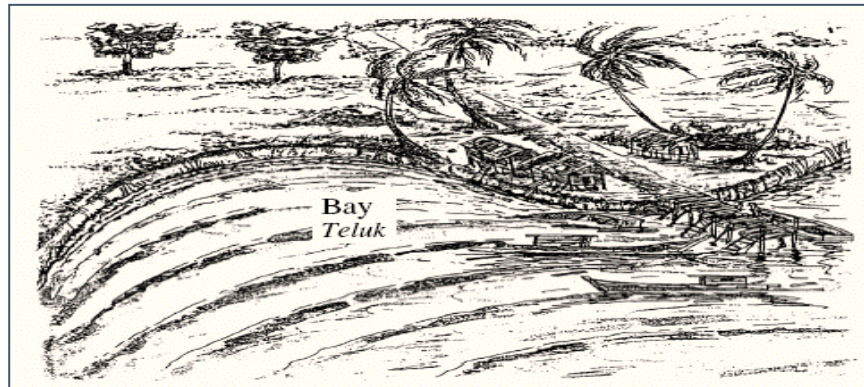

Rajah 1

*Diagram 1*

Untuk mengelakkan kerosakan yang serupa berulang pada masa hadapan, nelayan-nelayan itu bercadang untuk membina benteng dan memindahkan jeti ke tempat yang baru. Buat cadangan selanjutnya tentang cara untuk membantu nelayan itu mengatasi masalah mereka.

*To prevent similar damage in the future, the fishermen suggest building retaining walls and relocating the jetty. Make further suggestions of ways to help the fishermen solve their problems.*

Anda perlu menggunakan pengetahuan tentang pantulan, pembiasan dan pembelauan gelombang bagi menerangkan cadangan itu, yang merangkumi aspek-aspek berikut:  
*You should use your knowledge of reflection, refraction and diffraction of waves to explain these suggestions, to include the following aspects:*

- (a) reka bentuk dan struktur benteng  
*the design and structure of the retaining wall*
- (b) lokasi jeti yang hendak dibina  
*the location of the new jetty*
- (c) saiz atau tenaga gelombang  
*the size or energy of the waves*

[10 markah / 10 marks]

- 2** Anda telah ditugaskan sebagai pakar runding untuk memasang sistem pembesar suara untuk membaikpulih sistem bunyi di sebuah dewan sekolah. Dengan menggunakan konsep fizik, terangkan bagaimana pemasangan peralatan tersebut dan pengubahsuaian lain dilakukan untuk menghasilkan bunyi yang jelas.

*You have been assigned as a consultant to assemble a speaker system to improve the acoustics of a school hall. Using the appropriate physics concept explain how the installation of the speaker system and other modifications that can improve audible sound.*

Dalam penerangan anda, terangkan berdasarkan aspek-aspek berikut:

*In your explanation, elaborate on the following aspects:*

- Jarak antara dua pembesar suara stereo.  
*Distance between of two stereo speakers.*
- Kemas pada dinding dan lantai  
*Wall and floor finishing*
- Kedudukan pembesar suara dan mikrofon  
*Positioning of speakers and microphones*

[10 markah / 10 marks]

- 3 Rajah 3 menunjukkan sebuah restoran di sebuah bandar. Restoran tersebut sentiasa penuh dengan pelanggan dan selalu bising. Seorang pelajar dan ibu bapanya sering berkunjung ke restoran ini untuk menikmati makan malam yang menyenangkan. Restoran ini tidak sesuai untuk makan malam yang tenang dan mereka ingin mencadangkan beberapa pengubahsuaian kepada pemilik restoran.

*Diagram 3 shows a restaurant in one city. The restaurant is always packed with customers and is always noisy. A student and his parents often visit the restaurant to enjoy a pleasant dinner. The restaurant is not suitable for a quiet evening and they decided to suggest a few modifications to the restaurant owner.*



Rajah 3  
Diagram 3

Menggunakan konsep-konsep fizik yang sesuai, cadang dan terangkan pengubahsuaian yang perlu dibuat ke atas restoran tersebut. Pengubahsuaian yang dibuat mestilah melibatkan aspek-aspek berikut:

*Using the appropriate physics concepts, suggest and explain the modifications that have to be done to reduce the noise pollution. The modification should include the following aspects:*

- (i) Bahan yang digunakan untuk lantai, siling dan dinding.  
*Materials used for floor, ceiling and wall.*
- (ii) Kemasan untuk meja dan kaunter.  
*Finishing for table and countertops.*
- (iii) Penyelesaian bagi masalah tingkap besar.  
*Solution for large windows.*
- (iv) Rekaan ruang makan.  
*Dining space design.*

[10 markah / 10 marks]

**BAB 6 : CAHAYA DAN OPTIK / CHAPTER 6 : LIGHT AND OPTICS**

**BAHAGIAN A / SECTION A**

1 Rajah 1.1 menunjukkan lintasan cahaya merambat dari udara ke prisma.

*Diagram 1.1 shows a light path travel from air to prism.*

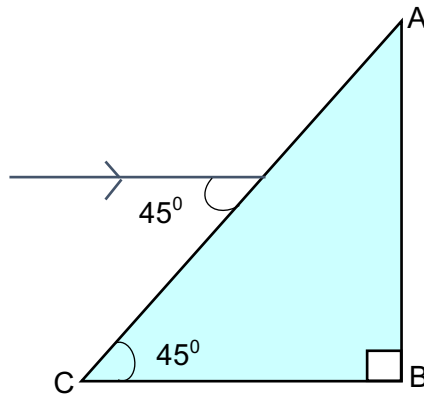

Rajah 1.1

*Diagram 1.1*

- (a) (i) Hitungkan sudut biasan sinar cahaya dalam prisma, jika indeks biasan prisma ialah 1.50.

*Calculate the refractive angle of the light in the prism, if the refractive index is 1.50.*

[2 markah / 2 marks]

- (ii) Adakah sinar cahaya itu akan mengalami pantulan dalam penuh pada sisi prisma AB? Terangkan jawapan anda.

*Will the light ray experience total internal reflection at AB? Explain your answer.*

.....  
.....

[2 markah / 2 marks]

- (b) Prisma pada Rajah 1.1 digunakan di dalam binokular. Rajah 1.2 menunjukkan susunan dua prisma  $45^\circ / 45^\circ$  dengan indeks biasan 1.50 di dalam binokular itu. *Prism in Diagram 1.1 is use in the binoculars. Diagram 1.2 shows the arrangement of the two  $45^\circ / 45^\circ$  glass prism of refractive index 1.50 inside the binoculars.*

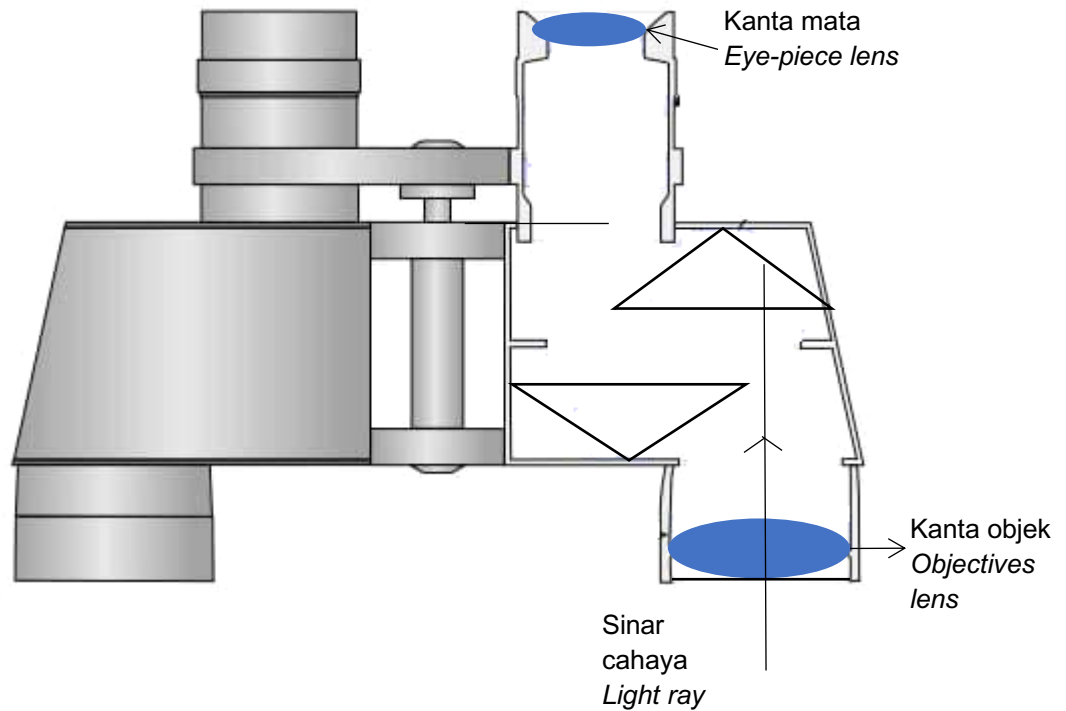

Rajah 1.2  
Diagram 1.2

Pada Rajah 1.2, lengkapkan lintasan sinar cahaya yang memasuki dua prisma melalui kanta objek.

*On Diagram 1.2, complete the path of the light ray entering the two prisms through the objective lens.*

[1 markah / 1 mark]

- (c) Sebuah kanta objektif digunakan dalam binokular supaya objek dapat dilihat dengan lebih jelas dan lebih besar. Nyatakan ciri-ciri yang sesuai bagi kanta digunakan sebagai kanta objek. Berikan  **satu**  sebab untuk ciri-ciri tersebut. *An objective lens is used in binoculars so that the object that can be seen clearer and bigger. State the suitable characteristics of the lens to be used s the objectives lens. Give **one** reason for the suitability of the characteristics.*

(i) Panjang fokus kanta itu  
*Focal length of the lens*

.....

Sebab

*Reason*

.....

[2 markah / 2 marks]

(ii) Diameter kanta itu  
*Diameter of the lens*

.....

Sebab

*Reason:*

.....

[2 markah / 2 marks]

2 Rajah 2 menunjukkan sebuah model teleskop yang dibina oleh seorang murid. Dia menggunakan dua kanta cembung yang berbeza diameter dan panjang fokus. Panjang fokus kanta yang digunakan untuk kanta objek dan kanta mata adalah 40 cm dan 10 cm masing-masing.

*Diagram 2 shows a telescope model make by a student. He uses two convex lens with different diameter focal length. Focal length that he uses for objectives lens and eye piece lens is 40 cm and 10 cm respectively.*



Rajah 2

*Diagram 2*

(a) Apakah yang dimaksudkan dengan kuasa kanta?

*What is meant by the power of lens?*

.....

[1 markah / 1 mark]

(b) Hitung kuasa kanta bagi:

*Calculate the power of lens for:*

(i) kanta objek

*Objective lens*

(ii) kanta mata

*Eye piece lens*

[3 markah / 3 marks]

(c) Beri satu sebab mengapa kuasa kanta mata lebih besar daripada kanta objek?

*Give one reason why the power of eye-piece lens is bigger than objective lens?*

.....

[1 markah / 1 mark]

(d) Teleskop yang dibina oleh murid itu tidak dapat menghasilkan imej yang jelas.

Cadangkan pengubahsuaian yang boleh dilakukan untuk menghasilkan imej yang jelas dan bersaiz besar berdasarkan aspek-aspek berikut:

*Telescope make by the students did not produced clear image. Suggest modification that can be done to produced clear and bigger image based on the following aspects:*

- (i) Nisbah panjang fokus kanta objek dan kanta mata  
*Ratio focal length of objective lens to eye piece lens.*

.....  
 Sebab  
*Reason*

[2 markah / 2 marks]

- (ii) Jarak antara kanta objek dan kanta mata.  
*distance between objective and eye-piece lens.*

.....  
 Sebab  
*Reason*

[2 markah / 2 marks]

**BAHAGIAN B DAN C / SECTION B AND C**

- 1 Dalam telekomunikasi, gentian optik kini secara beransur-ansur telah menggantikan penggunaan kabel kuprum. Rajah 1 menunjukkan struktur gentian optik yang digunakan untuk menghantar isyarat melalui cahaya.

*In telecommunication, optical fibre are now slowly replaced the copper cables. Diagram 1 shows a structure of optical fibre used to transmit signal through light.*

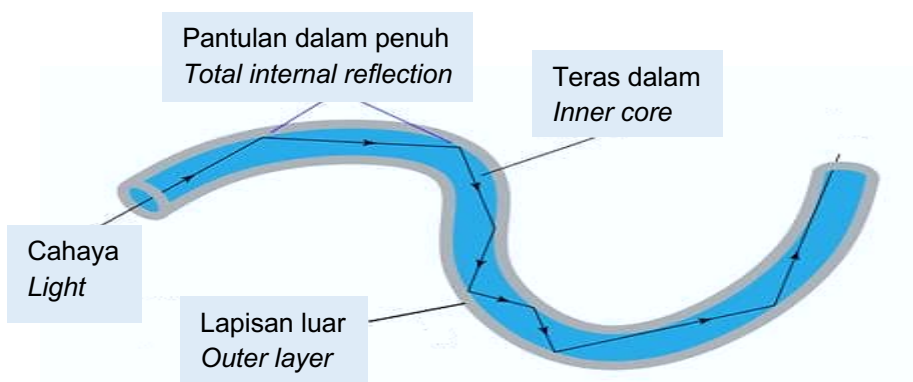

Rajah 1  
 Diagram 1

Dengan menggunakan pengetahuan mengenai cahaya dan sifat-sifat bahan, terangkan langkah yang diambil untuk mereka gentian optik yang boleh berfungsi dengan cekap berdasarkan aspek-aspek berikut:

*Using the knowledge about light and the properties of material, explain the steps taken to design fibre optics which can work efficiently, based on the following aspects:*

(i) Indeks pembiasan bagi lapisan luar dan teras dalam.

*The refractive index of outer layer and inner core.*

(ii) Kelenturan bahan yang digunakan.

*Flexibility of the material used.*

(iii) Ciri-ciri lain bagi bahan yang digunakan.

*Other characteristics of the material used.*

[10 markah / 10 marks]

2 Rajah 2 menunjukkan seorang pelajar menggunakan kanta pembesar untuk mengkaji struktur badan seekor rama-rama. Walaubagaimanapun kanta pembesar itu tidak sesuai untuk mengkaji tisu rama-rama itu.

*Diagram 2 shows a student using magnifying glass to observe the body structure of a butterfly. However, the magnifying glass is not suitable for observing the tissues of the butterfly.*



Rajah 2  
Diagram 2

Anda dikehendaki untuk mempertingkatkan keupayaan kanta pembesar itu supaya ia boleh digunakan untuk mengkaji tisu-tisu rama-rama dengan lebih jelas dan tepat.  
*You are required to improve the capability of the magnifying glass so that it can be used to observe the tissues of the butterfly clearly and accurately.*

Dengan menggunakan pengetahuan mengenai cahaya dan sifat-sifat kanta, nyata dan terangkan pengubahsuaian berdasarkan aspek-aspek berikut:

*Using the knowledge about light and the properties of lenses, state and explain the modification based on the following aspect:*

- (i) Bilangan kanta  
*Number of lenses*
- (ii) Panjang fokus kanta  
*Focal length length of lenses*
- (iii) Kedudukan objek  
*the position of object*
- (iv) Ciri-ciri tambahan yang diperlukan untuk mengkaji tisu-tisu dengan lebih jelas.  
*Other extra features needed to observe the tissues clearly.*

[10 markah / 10 marks]

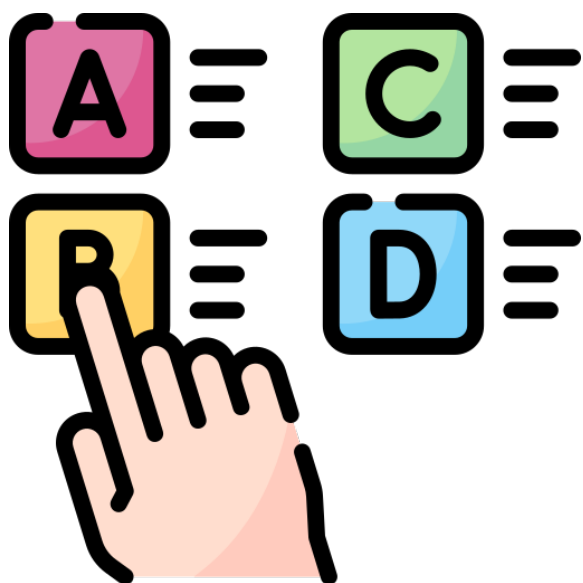

# SKEMA JAWAPAN

## *ANSWERS SCHEME*



# PENGETAHUAN / KEFAHAMAN / APLIKASI

## BAB 1 : PENGUKURAN / CHAPTER 1 : MEASUREMENT

### BAHAGIAN A / SECTION A

Soalan Question	Skema Pemarkahan Marking Scheme	Markah Marks
<b>1</b>	(a) Suhu termodinamik (terima suhu) <i>Thermodynamic temperature (accept temperature)</i>	1
	(b) 2 °C (tolak jawapan tanpa unit yang betul/ <i>reject answer without correct unit</i> )	1
	(c) 22 °C (tolak jawapan tanpa unit yang betul/ <i>reject answer without correct unit</i> )	1
	(d) Merkuri (terima symbol Hg)/Raksa <i>Mercury(accept symbol Hg)</i>	1

<b>2</b>	(a) 0.01 cm (tolak jawapan tanpa unit yang betul / <i>reject answer without correct unit</i> )	1
	(b) Tebal 1 helai kertas = $\frac{0.82 \text{ cm}}{100}$ ..... P1 = 0.0082 cm / $8.2 \times 10^{-3}$ cm..... P2	1 + 1
	(c) Ekor <i>Tail</i>	1
	(d) Tolok skru mikrometer <i>Micrometer screw gauge</i>	1

<b>3</b>	(a) Voltmeter	1
	(b) Beza keupayaan <i>Potential difference</i>	1
	(c) 2.7 V	1
	(d) Selari <i>Parallel</i>	1
	(e) Untuk mengelakkan ralat paralaks (P1) dengan memastikan tiada imej terbentuk di belakang jarum penunjuk (P2) <i>Avoid parallax error by no image formed at the back of the pointer.</i>	1 1

4	(a)	(i) Ralat sifar / ralat sistematik <i>Zero error / systematic error</i>	
		Cara mengatasi:	1
		- Dengan menolak atau menambah bacaan yang diambil dengan bacaan ralat sifar.	
		- Menggantikan dengan alat pengukuran yang baru	1
		<i>Ways to overcome:</i>	
		- <i>Deduct or add reading taken with the reading of zero error</i>	
		- <i>Replace the defective measuring instrument with a new one</i>	
	(ii) 2.0 s	1	
	(iii) Bacaan sebenar = Bacaan yang diambil – Bacaan Ralat Sifar = 26.0 s – 2.0 s = 24.0 s	1 1	
(b)	(i) $T = \frac{24.0 \text{ s}}{20}$ T = 1.2 s	1 1	
	(ii) $l = \left( \frac{g}{4\pi^2} \right) T^2$ $l = \left( \frac{10 \text{ m s}^{-2}}{39.489} \right) \times (1.2 \text{ s})^2$  l = 0.3647 m / 0.365 m / 36.5 cm (dengan unit yang betul)	1  1	

**BAHAGIAN B DAN C / SECTION B AND C**

Soalan Question	Skema Pemarkahan Marking Scheme	Markah Marks
<b>1</b>	(a) (i) Untuk menunjukkan perhubungan di antara dua pembolehubah <i>To show the relationship between two variables</i>	1
	Untuk menganalisis data <i>To analyse data</i>	1
	(ii) mempunyai nama, simbol, dan unit <i>Has name, symbol and unit</i>	1
	Dicatat dalam nilai yang konsisten (tempat perpuluhan yang seragam) <i>Recorded with a consistent value (uniform decimal places)</i>	1
	Direkod mengikut kepekaan alat pengukuran <i>Recorded according to the instrument's sensitivity</i>	1
	(b) (i) Pemboleh ubah dimanipulasikan = Jisim / m <i>Manipulated variable = mass / m</i>	1
	Pembolehubah bergerak balas = Daya / F <i>Responding variable = Force / F</i>	1
	(ii) Daya berkadar langsung dengan jisim / $F \propto m$ <i>Force is directly proportional to mass</i>	1
	(iii) $m = \frac{y_2 - y_1}{x_2 - x_1}$ $m = \frac{20\text{ N} - 0\text{ N}}{5\text{ kg} - 0\text{ kg}}$ $m = \frac{20\text{ N}}{5\text{ kg}}$ $m = 4\text{ N kg}^{-1}$ (jawapan akhir dengan unit yang betul)	1    1

**BAB 2 : DAYA DAN GERAKAN I / CHAPTER 2 : FORCE AND MOTION I**

**BAHAGIAN A / SECTION A**

Soalan Question	Skema Pemarkahan Marking Scheme	Markah Marks
<b>1</b>	(a) Daya graviti / Berat <i>Gravitational force / Weight</i> Rintangan udara <i>Air resistance</i>	1  1
	(b) (i) Halaju berkurang sehingga ia malar / pecutan berkurang sehingga sifar <i>Velocity decreases until becomes constant / acceleration decreases until becomes zero</i>	1
	(ii) Bola plastik <i>Plastic ball</i>	1
	(c) Rintangan udara berkurang / kelajuan meningkat / Ruang kawasan kecil <i>Less air resistance / higher speed / smaller space area</i>	1
	(d) Halaju sama / laju sama / Pecutan sama / pecutan $9.81 \text{ ms}^{-2}$ <i>Same velocity / same speed / same acceleration / acceleration <math>9.81 \text{ ms}^{-2}</math></i>	1

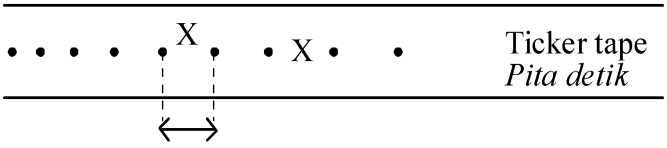
<b>2</b>	(a) Arus ulang alik <i>Alternating current</i>	1
	(b) Tanda 'X' antara mana-mana dua titik <i>Mark 'X' between any two dots</i>  <div style="text-align: center;">  <p style="text-align: right; margin-right: 50px;"><i>Ticker tape</i> <i>Pita detik</i></p> </div>	1
	(c) $\frac{5}{0.02 \times 5}$ or $\frac{5}{0.1}$  Jawapan dan unit betul <i>Correct answer and correct unit</i>  $50 \text{ cm s}^{-1}$ or $0.5 \text{ m s}^{-1}$	1   1

3	(a)	Daya Apung = Berat <i>Buoyant force = weight</i>	1
	(b)	$W = \text{buoyant force}$ $mg = V\rho g$ $m = 800 \times 1.25$ $= 1000 \text{ kg}$	1 1
	(c)	Mengurangkan isipadu udara dalam belon <i>Reduce the volume of the air in the balloon</i>	1

### BAHAGIAN B DAN C / SECTION B AND C

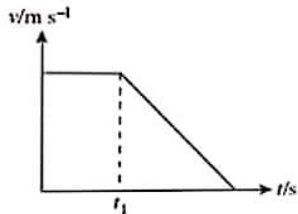
Soalan Question	Skema Pemarkahan Marking Scheme	Markah Marks	
1	(a)	Halaju adalah kadar perubahan sesaran <i>Velocity is the rate of change of displacement</i>	1
	(b)	 <p style="text-align: center;">- kereta tidak bergerak perlahan pada <math>t_1</math> kerana pada ketika ini pemandu telah melihat lampu kecemasan <i>The car does not slow down in the first <math>t_1</math> seconds because this is the time required for the driver act after seeing emergency lights</i></p> <p style="text-align: center;">- Selepas pemandu menekan brek, kereta mula bergerak perlahan hingga berhenti. <i>After this, the driver presses down on the brakes and the car begins to slow down until it is stationary.</i></p> <p style="text-align: center;">- Jarak bergerak semasa menggunakan brek ditentukan dengan luas di bawah graf. <i>The distance moved during the application of the brakes is determined by finding the area below the graph.</i></p>	2  1  1

	(c)	$v^2 = u^2 + 2as$	
		$v = 0$ (When the airplane stops)	
		$u = 50.0$	1
		$a = - 3.0$ (because of deceleration)	
		$(0^2) = (50.0)^2 + 2(-3.0)s$	1
		$2500 = 2(3.0)s$	
		$S = 416.67$	1
		The minimum length of the runway is 416.67 m	1

2	(a)	Hasil darab jisim dan halaju / $p = mv$ <i>Product of mass and velocity / <math>p = mv</math></i>	1
	(b)	- Cecair oksigen dan bahan bakar hidrogen dibakar dalam pembakaran <i>liquid oxygen and liquid hydrogen fuel is burnt in the combustion</i>	1
		- gas ekzos dikeluarkan dari roket dengan kelajuan tinggi <i>the exhaust gas is ejected out of the rocket at high speed</i>	1
		- momentum yang besar dihasilkan ke belakang <i>large backward momentum is produced</i>	1
		- roket memperoleh momentum besar ke hadapan <i>the rocket gained a large momentum forward</i>	1

## BAB 3 : KEGRAVITIAN / CHAPTER 3 : GRAVITATION

### BAHAGIAN A / SECTION A

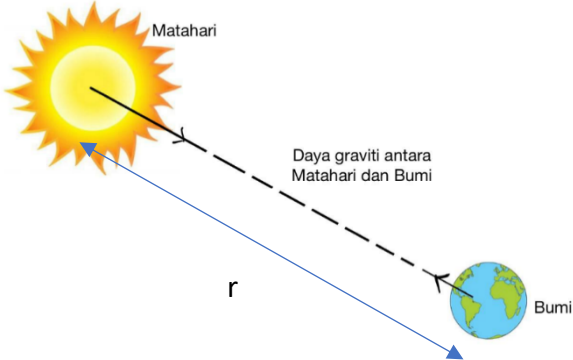
Soalan Question	Skema Pemarkahan Marking Scheme	Markah Marks
<b>1</b>	<p>(a) Daya gravity antara dua jasad adalah berkadar terus dengan hasil darab jisim kedua-dua jasad dan berkadar songsang dengan kuasa dua jarak antara pusat dua jasad tersebut.</p> <p><i>The gravitational force between two bodies is directly proportional to the product of the two bodies and inversely proportional to the square of the distance between the centers of the bodies</i></p>	1
	<p>(b)(i) Pemalar kegravitian</p> <p><i>Gravity constant</i></p>	1
	<p>(b)(ii) Jarak di antara dua pusat jasad</p> <p><i>Distance between the centers of the bodies</i></p>	1
		1
<b>2</b>	<p>(a)(i) Daya tarikan gravity berkadar langsung dengan hasil darab jisim dua jasad</p> <p><i>The gravitational force is directly proportional to the product of the masses of two bodies</i></p>	1
	<p>(a)(ii) Daya tarikan gravity berkadar songsang dengan kuasa dua jarak diantara pusat kedua jasad</p> <p><i>The gravitational force is inversely proportional to the square of the distance between the centers of the bodies</i></p>	1

	(b)	$F \propto m_1 m_2$	1
		$F \propto \frac{1}{r^2}$	1
		$F \propto \frac{m_1 m_2}{r^2}$	1
		$F = \frac{Gm_1 m_2}{r^2}$	1

3	(a)(i)	Orbit setiap planet berbentuk elips dengan matahari sebagai satu titik fokus <i>The orbit of each planet is elliptical to the sun as its focal point</i>	1
	(a)(ii)	Garis yang menyambungkan planet dengan matahari akan memberikan magnitude luas yang sama dalam selang masa yang sama apabila planet bergerak dalam orbit <i>The line that connects the planet to the sun gives equal magnitude of area as the similar time interval of the planet orbiting</i>	1
	(a)(iii)	Kuasa dua tempoh orbit berkadar terus dengan kuasa tiga jejari orbit <i>The square of the orbital period is directly proportional to the cube of orbit radius.</i>	1
	(b)	$F = \frac{GMm}{r^2}$ $F = \frac{mv^2}{r}$ $\frac{mv^2}{r} = \frac{GMm}{r^2}$ $v^2 = \frac{GM}{r}$ $v^2 \propto \frac{1}{r}$	1 1 1
	(c)	$v^2 = \frac{GM}{r}$ $v = \frac{2\pi r}{T}$ $\left(\frac{2\pi r}{T}\right)^2 = \frac{GM}{r}$ $\frac{4\pi^2 r^2}{T^2} = \frac{GM}{r}$ $T^2 = \frac{4\pi^2}{GM} r^3$ $T^2 \propto r^3$	1 1 1
			1

4	(a)	Halaju minimum yang diperlukan oleh objek di permukaan Bumi untuk mengatasi daya gravity dan terlepas ke angkasa lepas <i>The minimum velocity required by an object on Earth to overcome gravitational force and exit to space</i>	1
	(b)(i)	$v = \sqrt{\frac{2 \times (6.67 \times 10^{-11}) \times (6.42 \times 10^{23})}{7.35 \times 10^{22}}}$	1
		$v = 3.4 \times 10^{-5} \text{ m s}^{-1}$	1
	(b)(ii)	$v = \sqrt{\frac{2 \times (6.67 \times 10^{-11}) \times (3.4 \times 10^6)}{71.74 \times 10^6}}$ $v = 2.5 \times 10^{-6} \text{ m s}^{-1}$	1 1
(c)	Jisim planet <i>Planet mass</i>	1	
	Jarak objek dari pusat planet <i>Object distance from the center of the planet</i>	1	
	Jisim objek <i>Object mass</i>	1	

5	(a)	$\frac{T_E^2}{T_S^2} = \frac{r_E^3}{r_S^3}$	1
		$r_S^3 = \frac{T_S^2}{T_E^2} r_E^3$	1
		$r_S^3 = \frac{1.88^2}{1.00^2} (1.5 \times 10^{11})^3$ $r_S = 2.28 \times 10^{11} \text{ m}$	1
	(b)	$\frac{T_A^2}{T_E^2} = \frac{r_A^3}{r_E^3}$	1
		$T_A^2 = \frac{r_A^3}{r_E^3} T_E^2$ $T_A^2 = \frac{(1.90 \times 10^{11})^3}{(1.5 \times 10^{11})^3} (1)$ $T_A = 1.43 \text{ tahun}$	1 1

6	(a)(i)	<p>Daya graviti = Daya memusat</p> $\frac{GMm}{R^2} = \frac{mv^2}{r}$ <p>di mana <math>v = \frac{2\pi r}{T}</math></p> $GM = r\left(\frac{2\pi r}{T}\right)^2$ $T^2 = \frac{4\pi^2}{GM} r^3$	1
			1
			1
			1
	(a)(ii)	Hukum Kepler Ketiga <i>Kepler's Third Law</i>	1
	(b)(i)	$\frac{T_2^2}{r_2^3} = \frac{T_1^2}{r_1^3}$	1
		$T_2 = T_1 \sqrt{\left(\frac{r_2}{r_1}\right)^3}$	1
		$T_2 = (3.15 \times 10^7) \sqrt{\left(\frac{1.9 \times 10^9}{1.5 \times 10^{11}}\right)^3}$	1
	(b)(ii)	$\frac{GMm}{R^2} = \frac{mv^2}{r}$ di mana $v = \frac{2\pi r}{T}$	1
		$M = \frac{r}{G} \left(\frac{2\pi r}{T}\right)^2$	1
		$M = \frac{4\pi^2 r^3}{GT^2}$	1
		$M = \frac{4\pi^2}{6.67 \times 10^{-11}} \frac{(1.50 \times 10^{11})^3}{(3.15 \times 10^7)^2}$	1
		$M = 2.01 \times 10^{30} \text{ kg}$	1

**BAHAGIAN B DAN C / SECTION B AND C**

Soalan Question		Skema Pemarkahan Marking Scheme	Markah Marks
1	(a)(i)	Halaju minimum yang diperlukan oleh suatu objek untuk mengatasi daya graviti <i>Minimum velocity required by an object to overcome gravitational force</i>	1
	(ii)	Jejari orbit <i>Radius of orbit</i>	1

	Jisim badan pusat satelit mengorbit <i>Mass of the central body the satellite is orbiting</i>	1															
(b)(i)	<table border="1"> <thead> <tr> <th>Aspek</th> <th>Satelit Geopegun</th> <th>Satelit Bukan Geopegun</th> </tr> </thead> <tbody> <tr> <td><b>Arah gerakan</b> <i>Movement direction</i></td> <td>Arah gerakan sama dengan arah putaran Bumi. <i>The direction of motion is the same as the Earth's rotation</i></td> <td>Arah gerakan tidak perlu sama dengan arah putaran Bumi. <i>The direction of motion is not the same as the Earth's rotation</i></td> </tr> <tr> <td><b>Tempoh orbit</b> <i>Orbital period</i></td> <td>24 jam. <i>24 hours</i></td> <td>Kurang atau lebih panjang daripada 24 jam. <i>Less or more than 24 hours</i></td> </tr> <tr> <td><b>Perubahan kedudukan pada orbit</b> <i>Change of position in orbit</i></td> <td>Berada di atas tempat yang sama di muka Bumi <i>Stationary on the same location</i></td> <td>Berada di tempat yang berubah-ubah di muka Bumi. <i>Changes its location</i></td> </tr> <tr> <td><b>Fungsi</b> <i>Function</i></td> <td>Satelit komunikasi <i>Communiation satellite</i></td> <td>Satelit pengimejan bumi Satelit GPS Satelit Kaji Cuaca <i>Earth imaging satellite</i> <i>GPS Satellite</i> <i>Meteorological Satellite</i></td> </tr> </tbody> </table>	Aspek	Satelit Geopegun	Satelit Bukan Geopegun	<b>Arah gerakan</b> <i>Movement direction</i>	Arah gerakan sama dengan arah putaran Bumi. <i>The direction of motion is the same as the Earth's rotation</i>	Arah gerakan tidak perlu sama dengan arah putaran Bumi. <i>The direction of motion is not the same as the Earth's rotation</i>	<b>Tempoh orbit</b> <i>Orbital period</i>	24 jam. <i>24 hours</i>	Kurang atau lebih panjang daripada 24 jam. <i>Less or more than 24 hours</i>	<b>Perubahan kedudukan pada orbit</b> <i>Change of position in orbit</i>	Berada di atas tempat yang sama di muka Bumi <i>Stationary on the same location</i>	Berada di tempat yang berubah-ubah di muka Bumi. <i>Changes its location</i>	<b>Fungsi</b> <i>Function</i>	Satelit komunikasi <i>Communiation satellite</i>	Satelit pengimejan bumi Satelit GPS Satelit Kaji Cuaca <i>Earth imaging satellite</i> <i>GPS Satellite</i> <i>Meteorological Satellite</i>	1 + 1  1 + 1  1 + 1  1 + 1
Aspek	Satelit Geopegun	Satelit Bukan Geopegun															
<b>Arah gerakan</b> <i>Movement direction</i>	Arah gerakan sama dengan arah putaran Bumi. <i>The direction of motion is the same as the Earth's rotation</i>	Arah gerakan tidak perlu sama dengan arah putaran Bumi. <i>The direction of motion is not the same as the Earth's rotation</i>															
<b>Tempoh orbit</b> <i>Orbital period</i>	24 jam. <i>24 hours</i>	Kurang atau lebih panjang daripada 24 jam. <i>Less or more than 24 hours</i>															
<b>Perubahan kedudukan pada orbit</b> <i>Change of position in orbit</i>	Berada di atas tempat yang sama di muka Bumi <i>Stationary on the same location</i>	Berada di tempat yang berubah-ubah di muka Bumi. <i>Changes its location</i>															
<b>Fungsi</b> <i>Function</i>	Satelit komunikasi <i>Communiation satellite</i>	Satelit pengimejan bumi Satelit GPS Satelit Kaji Cuaca <i>Earth imaging satellite</i> <i>GPS Satellite</i> <i>Meteorological Satellite</i>															
(b)(ii)	<ul style="list-style-type: none"> <li>- Orbit mengelilingi Bumi <i>Orbits around the Earth</i></li> <li>- Jatuh bebas mengelilingi Bumi <i>Free fall around the Earth</i></li> <li>- Daya graviti bertindak sebagai daya memusat <i>Gravitational force acts as centripetal force</i></li> <li>- Gerakan mematuhi Hukum Kepler Ketiga <i>Motion follows Kepler's Third Law</i></li> </ul>	1  1  1  1															
(b)(iii)	Satelit akan jatuh ke dalam orbit lebih dekat dengan Bumi <i>The satellite will fall into an orbit closer to Earth</i>	1															

		<p>Daya memusat menjadi lebih rendah daripada daya graviti Bumi ke atas satelit di orbit asalnya.</p> <p><i>The centripetal force becomes lower than the gravitational force of the Earth on the satellite in its original orbit</i></p>	1
	(c)	<ul style="list-style-type: none"> <li>- Ketumpatan badan berkurang <i>Density decreases</i></li> <li>- Tulang menjadi lebih rapuh disebabkan kekurangan kalsium <i>Bones will become fragile due to lack of calcium</i></li> <li>- Paru-paru menjadi besar dan mengembang <i>Lungs will expand and becomes large</i></li> <li>- Darah akan terkumpul di bahagian atas badan <i>Blood will gather in the upper part of the body</i></li> <li>- Penurunan tekanan darah dan kadar degupan jantung <i>Drop in blood pressure and rate of heartbeat</i></li> </ul>	<p>1</p> <p>1</p> <p>1</p> <p>1</p> <p>1</p>
			Max : 2

2	(a)	<p>Hukum Kegravitian Semesta Newton menyatakan bahawa daya graviti antara dua jasad adalah berkadar terus dengan hasil darab jisim kedua-dua jasad dan berkadar songsang dengan kuasa dua jarak di antara pusat dua jasad tersebut</p> <p><i>Newton's Universal Gravitation Law states that the gravitational force between two bodies is directly proportional to the product of the two body mass and inversely proportional to the square of distance between the two bodies</i></p>	1
	(b)	<p>Hukum Kegravitian Semesta Newton</p> <p><i>Newton's Universal Gravitation Law</i></p> $F = \frac{GMm}{r^2} \text{-----(1)}$ <p>Hukum Gerakan Newton Kedua</p> $F = mg \text{-----(2)}$ $mg = \frac{GMm}{r^2}$ $g = \frac{GM}{r^2}$	<p>1</p> <p>1</p> <p>1</p> <p>1</p>

(c)	<b>Aspek</b> <b>Aspect</b>	Kesan graviti rendah <i>Low gravity effect</i>	Kesan graviti tinggi <i>High gravity effect</i>	
	<b>Perubahan ketumpatan</b> <b>Density changes</b>	Ketumpatan badan berkurang <i>Density decreases</i>	Ketumpatan badan meningkat <i>Density increases</i>	1 + 1
	<b>Kerapuhan tulang</b> <b>Bone fragility</b>	Tulang menjadi lebih rapuh disebabkan kekurangan kalsium <i>Bones become fragile due to lack of calcium</i>	Tiada perubahan ketara <i>No significant changes</i>	1 + 1
	<b>Saiz paru-paru</b> <b>Lung size</b>	Membesar dan mengembang <i>Increases and expand in size</i>	Mengecil dan mengecut <i>Decreases and shrink in size</i>	1 + 1
	<b>Sistem aliran darah</b> <b>Bloodflow system</b>	Darah terkumpul di bahagian atas badan <i>Blood gathers in the upper part of the body</i>	Darah terkumpul di bahagian bawah badan disebabkan kesukaran untuk mengalir ke atas <i>Blood gathers in the lower part of the body</i>	1 + 1
	<b>Tekanan darah</b> <b>Blood pressure</b>	Penurunan tekanan darah dan kadar degupan jantung <i>Blood pressure drops, rate of heartbeat drops</i>	Peningkatan tekanan darah dan kadar degupan jantung <i>Blood pressure rises, rate of heartbeat increase</i>	1 + 1
	(d)(i)	$M = \frac{4\pi^2 r^3}{GT^2}$		
(d)(ii)	Jejari mana-mana satelit atau Bulan, $r$ <i>Radius of any satellite or moon, <math>r</math></i>			1
	Tempoh peredaran, $T$ <i>Circulating period, <math>T</math></i>			1
(d)(iii)	Jejari orbit mana-mana planet, $r$ <i>Orbital radius of any planet, <math>r</math></i>			1
	Tempoh peredaran planet tersebut, $T$ <i>Circulation period of the planet, <math>T</math></i>			1

3	(a)	<p>Halaju lepas ialah halaju minimum yang diperlukan oleh objek di permukaan Bumi untuk mengatasi daya graviti dan terlepas ke angkasa lepas.</p> <p><i>Escape velocity is the minimum velocity required by an object to overcome gravitational force and exit to outer space.</i></p>	1
	(b)(i)	<p>Jisim Matahari, <i>Sun's mass</i> = <math>1.99 \times 10^{30}</math> kg            Jejari Matahari, <i>Sun's radius</i> = <math>6.96 \times 10^8</math> m            Jisim Bumi, <i>Earth's mass</i> = jisim <math>5.97 \times 10^{24}</math> kg            Jejari Bumi, <i>Earth's radius</i> = <math>6.37 \times 10^6</math> m            Jisim Bulan, <i>Moon's mass</i> = <math>7.35 \times 10^{22}</math> kg            Jejari Bulan, <i>Moon's radius</i> = <math>1.74 \times 10^6</math> m</p> $g = \frac{GM}{R^2}$ <p>Pecutan graviti Matahari, <i>Sun's gravity acceleration</i>,</p> $g = \frac{(6.67 \times 10^{-11})(1.99 \times 10^{30})}{(6.96 \times 10^8)^2}$ <p><math>g = 274.0 \text{ m s}^{-2}</math></p> <p>Pecutan graviti Bumi, <i>Earth's gravity acceleration</i>,</p> $g = \frac{(6.67 \times 10^{-11})(5.97 \times 10^{24})}{(6.37 \times 10^6)^2}$ <p><math>g = \quad \text{m s}^{-2}</math></p> <p>Pecutan graviti Bulan, <i>Moon's gravity acceleration</i>,</p> $g = \frac{(6.67 \times 10^{-11})(7.35 \times 10^{22})}{(1.74 \times 10^6)^2}$ <p><math>g = 1.62 \text{ m s}^{-2}</math></p> <p>Pecutan graviti Matahari, <i>Sun's gravity acceleration</i> &gt; Pecutan graviti Bumi, <i>Earth's gravity acceleration</i> &gt; Pecutan graviti Bulan, <i>Moon's gravity acceleration</i></p>	1 1 1 1 1 1
	(b)(ii)	<p>Jisim Matahari, <i>Sun's mass</i> = <math>1.99 \times 10^{30}</math> kg            Jejari Matahari, <i>Sun's radius</i> = <math>6.96 \times 10^8</math> m            Jisim Bumi, <i>Earth's mass</i> = <math>5.97 \times 10^{24}</math> kg            Jejari Bumi, <i>Earth's radius</i> = <math>6.37 \times 10^6</math> m            Jisim Bulan, <i>Moon's mass</i> = <math>7.35 \times 10^{22}</math> kg            Jejari Bulan, <i>Moon's radius</i> = <math>1.74 \times 10^6</math> m</p>	1 1 1

	$v = \sqrt{\frac{2GM}{R}}$ <p>Halaju lepas dari Matahari, <i>Escape velocity from the Sun,</i></p> $v = \sqrt{\frac{2 \times (6.67 \times 10^{-11})(1.99 \times 10^{30})}{6.96 \times 10^8}}$ $v = 6.18 \times 10^5 \text{ms}^{-1}$ <p>Halaju lepas dari Bumi, <i>Escape velocity from the Earth,</i></p> $v = \sqrt{\frac{2 \times (6.67 \times 10^{-11})(5.97 \times 10^{24})}{6.37 \times 10^6}}$ $v = 1.12 \times 10^4 \text{ms}^{-1}$ <p>Halaju lepas dari Bulan, <i>Escape velocity from the Moon,</i></p> $v = \sqrt{\frac{2 \times (6.67 \times 10^{-11})(7.35 \times 10^{22})}{1.74 \times 10^6}}$ $v = 2.37 \times 10^3 \text{ms}^{-1}$ <p>Halaju lepas dari Matahari, <i>Escape velocity from the Sun</i> &gt; Halaju lepas dari Bumi, <i>Escape velocity from the Earth</i> &gt; Halaju lepas dari Bulan, <i>Escape velocity from the Moon</i></p>	<p>1</p> <p>1</p> <p>1</p> <p>1</p> <p>1</p>
(c)	<p>Halaju lepas (<i>Escape velocity</i>), <math>v = \sqrt{\frac{2GM}{R}}</math></p> <p>Di permukaan Marikh (<i>On Mars' surface</i>), <math>v_1 = \sqrt{\frac{2GM}{R}}</math></p> <p>Pada altitude, <i>At altitude</i> <math>0.5R</math>, jarak dari pusat Marikh, <i>distance form center of Mars</i> <math>= 0.5R + R = 1.5R</math></p> $v_2 = \sqrt{\frac{2GM}{1.5R}}$ $v_2 = \sqrt{\frac{1}{1.5}} \sqrt{\frac{2GM}{R}}$ $v_2 = \sqrt{\frac{1}{1.5}} \times 5.02 \text{ km s}^{-1}$ $v_2 = 4.40 \text{ km s}^{-1}$	<p>1</p> <p>1</p> <p>1</p> <p>1</p> <p>1</p>

## BAB 4 : HABA / CHAPTER 4 : HEAT

### BAHAGIAN A / SECTION A

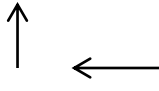
Soalan Question	Skema Pemarkahan Marking Scheme	Markah Marks
<b>1</b>	(a) Kuantiti haba yang diperlukan untuk menaikkan suhu sebanyak 1° C bagi 1 kg bahan itu / <i>Amount of energy required to raise the temperature of 1 kg of the substance by 1°C</i>	1
	(b)  Bayu Laut / <i>Sea Breeze</i>	1  1
	(c) $c = \frac{Q}{m\theta}$ $c = \frac{100000}{10000(0.00256)}$ $c = 3906.25 \text{ J kg}^{-1} \text{ }^\circ\text{C}^{-1}$	1  1
	(d) Tengahari yang panas / <i>hot afternoon</i>	1
<b>2</b>	(a) Tekanan berkurang apabila kedalaman berkurang / <i>Pressure decreases as depth decreases</i>	1
	(b) Hukum Boyle / <i>Boyle's Law</i>	1
	(c) Berkurang / <i>decreases</i>	1
	(d) $P_1 = 10 + 0.5 = 10.5 \text{ m}$ $P_1V_1 = P_2V_2$ $(10.5)(5) = (10)V$ $V = 5.25 \text{ cm}^3$	1  1
<b>3</b>	(a) Cecair kepada gas / <i>Liquid to gas</i>	1
	(b) Daya ikatan antara molekul-molekul air diputuskan Haba dari badan diserap untuk memutuskan daya ikatan itu <i>The binding forces between water molecules break.</i> <i>The heat from the body is used / absorbed to break the binding forces</i>	1  1
	(c) Haba pendam tentu pengewapan / <i>Latent heat of vaporisation</i>	1

	(d)	$Q = ml$	1
		$= 0.05(2.3 \times 10^6)$	
		$Q = 1.15 \times 10^5 \text{ J}$	1

### BAHAGIAN B DAN C / SECTION B AND C

Soalan Question	Skema Pemarkahan Marking Scheme	Markah Marks
<b>1</b>	(a) Kadar pemindahan haba bersih sifar / suhu sama <i>The net rate of heat transfer is zero / same temperature</i>	1
	(b) 1. Apabila sudu keluli diletakkan ke dalam kopi panas, sudu keluli bersentuhan dengan kopi panas. <i>When the stainless-steel spoon put inside the hot coffee, the spoon in the contact with coffee.</i>	1
	2. Haba daripada kopi panas dipindahkan kepada sudu besi <i>Heat is transferred from hot coffee to the spoon</i>	1
	3. Apabila kadar pemindahan haba bersih sifar <i>The net rate of heat transferred zero</i>	1
	4. keseimbangan terma tercapai <i>Thermal equilibrium</i>	1
<b>1</b>	(c) $Pt = mL$	1
	$L = \frac{(400)(1.8 \times 60)}{0.03}$	1
	$L = 1.44 \times 10^6 \text{ J kg}^{-1}$	1
	$t = (4.6-3.8) \times 60 = 48 \text{ s}$	1
	$Pt = mc\theta$	1
	$c = \frac{(400)(48)}{(0.03)(216-72)}$	1
	$c = 4.44 \times 10^3 \text{ J kg}^{-1}\text{C}^{-1}$	1

<b>2</b>	(a) 1. Lautan sangat dalam, oleh itu tekanan di dasar laut tinggi. <i>The ocean is deep so the pressure is high at seabed.</i>	1
	2. Secara semulajadi ikan ini suka tinggal di persekitaran tekanan tinggi. <i>The nature of the fish to stay in the high pressure surrounding.</i>	1
	3. Apabila dibawa ke permukaan isipadu bertambah, tekanan berkurang	1

		<p><i>When brought towards surface the volume increases, the pressure decreases.</i></p> <p>4. Gas dalam badan akan mengembang dan ikan akan meletup</p> <p><i>The gas in the body will expand so the internal organ of the fish will be burst</i></p>	1
3	(i)	$T_1 = 27 + 273 = 300 \text{ K}$ $T_2 = 155 + 273 = 428 \text{ K}$ $\frac{150\text{M}}{300} = \frac{P_2}{428}$ $P_2 = 214 \text{ MPa}$	1
			1
	(ii)	$Q = mc\Theta$ $c = \frac{2000}{(14)(155 - 27)}$ $= 1.116 \text{ J kg}^{-1} \text{ }^\circ\text{C}^{-1}$	1
			1
4	1.	<p>Konduktor yang baik mempunyai muatan haba tentu kecil</p> <p><i>Good heat conductor has a smaller specific heat capacity</i></p>	1
	2.	<p>Badan periuk boleh dipanaskan dengan cepat</p> <p><i>The body of the cooking pot can heat easily</i></p>	1
	3.	<p>Konduktor haba yang lemah mempunyai muatan haba tentu yang besar</p> <p><i>Poor conductor heat has a bigger specific heat capacity</i></p>	1
	4.	<p>Pemegang tidak mudah menjadi panas</p> <p><i>The handle will not become too hot</i></p>	1
5	1.	<p>Kapsul angkasa dalam perjalanan ke bumi akan mengalami geseran udara</p> <p><i>Space capsule that experiences air resistance as it enters Earth</i></p>	1
	2.	<p>Geseran ini akan meningkatkan suhu</p> <p><i>The resistance increases temperature</i></p>	1
	3.	<p>Lapisan luar kapsul angkasa diperbuat daripada muatan haba tentu yang tinggi</p> <p><i>The outer layer of the space capsule is made of materials with high specific heat capacity</i></p>	1
	4.	<p>Ini menyebabkan kapsul lambat panas dan tidak mudah terbakar</p> <p><i>This causes the capsule to heat up slower and not easily burn</i></p>	1

## BAB 5 : GELOMBANG / CHAPTER 5 : WAVES

### BAHAGIAN A / SECTION A

Soalan Question	Skema Pemarkahan Marking Scheme	Markah Marks
<b>1</b>	(a) Pembiasan <i>Refraction</i>	1
	(b) Merambat dari air dalam ke air cetek / bergerak ke air cetek / berbeza kedalaman / /perubahan halaju / perubahan panjang gelombang <i>Propagate from deep water to shallow water / move to shallow water / different depth / change velocity / change of wavelength</i>	1
	(c) Halaju / panjang gelombang <i>Speed / wavelength</i>	1
	(d) $2.5 \div 1.2$ Jawapan dalam unit yang betul Answer with correct unit 2.083 Hz	1    1
<b>2</b>	(a) Sinar-X, cahaya tampak, infra-merah, gelombang mikro <i>X-ray, visible light, infrared, microwave</i>	1
	(b) Cahaya tampak, infra-merah <i>Visible light, infra-red</i>	1
	(c) Komunikasi radio/ ketuhar mikro/ radar <i>Radio communication /in microwave oven / radar</i>	1
	(c) $f = \frac{c}{\lambda} = \frac{3.0 \times 10^8}{5.0 \times 10^{-2}}$ $= 6.0 \times 10^9 \text{ Hz}$	1   1
<b>3</b>	(a) Pembelauan gelombang air <i>Diffraction of water waves</i>	1
	(b) Amplitud berkurang <i>The amplitude decrease</i> Tenaga tersebar pada kawasan yang lebih luas <i>Energy is spread over a wider area</i>	1  1

	(c)	$v = \frac{2}{5} \times 5$	1
		$= 2 \text{ cm s}^{-1}$	1

**BAHAGIAN B DAN C / SECTION B AND C**

Soalan Question	Skema Pemarkahan Marking Scheme		Markah Marks	
1	(a)	Dua sumber koheren adalah dua sumber gelombang yang mempunyai fasa gelombang yang sama / tetap <i>Two coherent sources are two sources of oscillations which have a constant phase difference.</i>	1	
	(b)	Frekuensi yang sama <i>Same frequency</i>	1	
	(c)	(i)	P: Interferens memusnah <i>Destructive interference</i>	1
		(ii)	Q: Interferens membina <i>Constructive interference</i>	1
		(iii)	R: Interferens membina <i>Constructive interference</i>	1

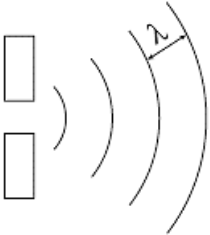
2	(a)	Penyebaran atau pembengkokan gelombang di sekeliling satu penghalang atau bukaan kecil. <i>The spreading or bending of waves around an obstacle or small opening</i>	1
	(b)		1
		Shape of waves Same wavelength	1
	(c)	(i)	- Kurang pembelauan / kurang penyebaran <i>Less diffraction / less spreading</i> atau <i>or</i> - Tenaga gelombang bertambah. <i>Wave energy increases.</i>
(ii)		Kerosakan terhadap pelabuhan/hakisan tanah lebih banyak <i>More damage to the harbour/soil erosion</i>	1

3	(a)	Interferens <i>Interference</i>	1	
	(b)	Meningkat <i>Increase</i>	1	
	(c)	(i)	Berayun ke atas dan ke bawah dengan amplitud yang besar <i>Oscillates up and down with a large amplitude</i>	1
		(ii)	Interferens membina berlaku di titik P <i>Constructive interference occurs at P</i>	1
	(d)	Jarak antara dua garis antinod yang berturutan bertambah <i>Distance between two consecutive antinodal lines increases</i> Panjang gelombang bertambah <i>Wavelength is longer</i> Laju gelombang air bertambah <i>Speed of the waves increase</i>	1 1 1	

4	(a)	Sumber yang koheren adalah sumber yang menghasilkan gelombang dengan frekuensi / panjang gelombang yang sama dan sefasa. <i>Coherent sources are sources that produce waves of the same frequency / wavelength and that are in phase.</i>	1
	(b)	- Kapal itu bergerak ke atas dan ke bawah dengan amplitud tinggi di A. <i>The ship moves up and down with high amplitude at location A.</i>	1
		- Interferens membina berlaku di A. <i>Constructive interference occurs at A.</i>	1
		- Kapal itu tetap tenang/tidak bergerak di kedudukan B. <i>The ship remains calm/does not move at location B.</i>	1
- Interferens memusnah berlaku di B. <i>Destructive interference occurs at B.</i>		1	

## BAB 6 : CAHAYA DAN OPTIK / CHAPTER 6 : LIGHT AND OPTICS

### BAHAGIAN A / SECTION A

Soalan Question	Skema Pemarkahan Marking Scheme	Markah Marks
1	(a) Cermin cekung / <i>Concave mirror</i> (b) Pantulan/ <i>Reflection</i> (c) Maya, tegak, diperbesar / <i>Virtual, upright, enlarge</i> (d)	1  1  1
		1+1+1
2	(a) (i) $0^\circ$ (ii) $45^\circ$ (iii) $\sin c = \frac{1}{1.5}$ $c = 41.81^\circ$	1  1  1  1

### BAHAGIAN B DAN C / SECTION B AND C

Soalan Question	Skema Pemarkahan Marking Scheme	Markah Marks
1	(a) (i) Logamaya <i>Mirage</i> (ii) - Lapisan udara dekat dengan permukaan jalan lebih panas daripada lapisan udara di atasnya. <i>- The air layer near the road surface is hotter.</i> - Udara panas adalah kurang tumpat daripada udara sejuk. <i>- Hot air is less dense than cold air.</i> - Sinar cahaya dibiaskan menjauhi normal apabila merambat dari medium lebih tumpat ke medium kurang tumpat.	1  1  1  1

	<ul style="list-style-type: none"> <li>- <i>A light ray from the sky is refracted away from the normal when travelling from denser to less dense air.</i></li> <li>- <i>Sudut tuju semakin bertambah sehingga melebihi sudut genting, pantulan dalam penuh berlaku.</i></li> <li>- <i>Incident angle increases until it exceeds the critical angle, total internal reflection occurs.</i></li> <li>- <i>Pemerhati melihat imej yang terbentuk sebagai lopak air.</i></li> <li>- <i>The observer sees the image formed as a pool of water.</i></li> </ul>	1
	<p>(b) (i) <math>\frac{1}{f} = \frac{1}{u} + \frac{1}{v}</math></p> $\frac{1}{v} = \frac{1}{10} - \frac{1}{25}$ $v = 16.7 \text{ cm}$ $m = \frac{v}{u} = \frac{16.7}{25} = 0.67$	1 1
	<p>(ii) Nyata, songsang dan dikecilkan <i>Real, inverted and diminished</i></p>	1 + 1  1

Soalan Question	Skema Pemarkahan Marking Scheme	Markah Marks
2	<p>(a) Sudut antara sinar tuju dan garis normal <i>Angle between incident ray and normal line</i></p> <p>(b) - Tingkatkan sudut tuju, i. Oleh itu, sudut biasan, r juga akan meningkat <i>Increase the angle of incidence, i. Then the angle of refraction, r will also increase</i></p> <ul style="list-style-type: none"> <li>- Terus menaikkan sudut tuju sehingga sudut pembiasan adalah 90° <i>Keep on increasing the angle of incidence until angle of refraction is 90°</i></li> <li>- Menaikkan sudut tuju lebih daripada sudut genting. <i>Increase the angle of incidence more than the critical angle.</i></li> <li>- Sinar akan dipantulkan. <i>The ray will be reflected.</i></li> </ul>	1  1  1  1  1

# MENGKONSEPSI / CONCEPTUALISING

## BAB 2 : DAYA DAN GERAKAN I / CHAPTER 2 : FORCE AND MOTION I

### BAHAGIAN A / SECTION A

Soalan Question	Skema Pemarkahan Marking Scheme	Markah Marks
<b>1</b>	(a) Kadar perubahan momentum <i>Rate of change of momentum</i>	1
	(b) Masa pelanggaran Rajah 1.1 > Rajah 1.2 <i>Time of impact diagram 1.1 &gt; rajah 1.2</i>	1
	(c) Daya impuls Rajah 1.1 < Rajah 1.2 <i>Impulsive force Diagram 1.1 &lt; Diagram 1.2</i>	1
	(d) Kesakitan Rajah 1.1 < Rajah 1.2 <i>Pain in Diagram 1.1 &lt; Diagram 1.2</i>	1
	(e) Masa pelanggaran meningkat, daya impuls berkurang, kesakitan berkurang <i>Time of impact increase, impulsive force decrease, pain decrease</i>	1
	(f) Memakai stokin tebal <i>Wear thick socks</i>	1
<b>2</b>	(a) Kecenderungan suatu objek untuk kekal dalam keadaan pegun atau dalam keadaan halaju seragam <i>Tendency of object to remain at rest or moving with uniform velocity</i>	1
	(b) Jisim pada Rajah 2.1 < Rajah 2.2 <i>Mass in Diagram 2.1 &lt; Diagram 2.2</i>	1
	(c) Inersia di Rajah 2.1 < Rajah 2.2 <i>Inertia in Diagram 2.1 &lt; Diagram 2.2</i>	1
	(d) Inersia kontena barangan untuk kekal dalam keadaan pegun <i>Inertia of crate to remain at rest</i>	1
	(e) Goncangkan botol ke atas dan bawah, sos akan mengalir keluar <i>Shake bottle up and down, sauce comes out</i>	1

<b>3</b>	(a)	Jarak ialah panjang lintasan yang dilalui oleh sesuatu objek <i>Distance is the length of path travelled by an object.</i>	1
	(b)	Masa = 10 minit = 600 s	1
		Laju = $\frac{\text{Jarak}}{\text{Masa}}$ $= \frac{150 \text{ m}}{600 \text{ s}}$ $= 0.25 \text{ m s}^{-1}$	1
		(c)	Masa = 15 minit = 900 s  Laju = $\frac{\text{Jarak}}{\text{Masa}}$ $= \frac{150 \text{ m}}{900 \text{ s}}$ $= 0.17 \text{ m s}^{-1}$
	(d)	(i) $t_{AB} < t_{BC}$	1
		(ii) $d_{AB} = d_{BC}$	1
(iii) $v_{AB} > v_{BC}$		1	
(e)	Masa berkadar songsang dengan laju <i>Time is inversely proportional to speed</i>	1	

### BAHAGIAN B DAN C / SECTION B AND C

Soalan Question	Skema Pemarkahan Marking Scheme		Markah Marks
<b>1</b>	(a)	(i) Momentum, $p$ ialah hasil darab jisim dengan halaju. $p = mv$ di mana $m$ = jisim dan $v$ = halaju. Unitnya ialah $\text{kg m s}^{-1}$ <i>Momentum, <math>p</math> is the product of the mass and velocity.</i> <i><math>p = mv</math> where <math>m</math> = mass and <math>v</math> = velocity.</i> <i>The unit of momentum is <math>\text{kg m s}^{-1}</math></i>	1
		(ii) Bentuk bebola plastisin lebih leper apabila menghempap permukaan kayu yang lebih tegar dan keras berbanding permukaan span yang lembut. <i>The shape of the plasticine ball is more flat when the plasticine ball hits the wooden surface, which is more rigid and hard as compared to the surface of the soft sponge.</i> Apabila bebola plastisin menghempap permukaan kayu, masa untuk berhenti lebih singkat. <i>When the plasticine ball hits the surface of the wood, the time of impact is shortened.</i>	1  1

		<p>Ini mewujudkan daya impuls yang besar. <i>This creates a high impulsive force.</i></p>	1
		<p>Apabila bebola plastisin menghempap permukaan span, permukaan span terperosok. Masa yang panjang diperlukan untuk bebola plastisin berhenti, menyebabkan daya impuls yang kecil wujud. <i>When the plasticine ball hits the surface of the sponge, the time of impact is lengthened, causing a shorter impulsive force.</i></p>	1
		<p>Daya impuls berkadar songsang dengan masa perlanggaran. <i>The impulsive force is directly proportional to the time of impact.</i></p>	1
	(b)	<p>Jumlah tenaga dalam suatu sistem tetap adalah sentiasa sama. <i>The total amount of energy in each system is constant.</i></p>	1
		<p>Sebelum dilepaskan, plastisin mempunyai tenaga keupayaan graviti disebabkan kedudukannya. <i>Before it is released, the plasticine has gravitational potential energy as a result of its position.</i></p>	1
		<p>Semasa plastisin sedang jatuh, tenaga keupayaan graviti berubah menjadi tenaga kinetik. <i>When the plasticine is falling, the gravitational potential energy is transferred to kinetic energy.</i></p>	1
		<p>Tenaga kinetik berubah menjadi tenaga haba dan tenaga bunyi apabila plastisin menyentuh permukaan kayu atau span. <i>When the plasticine hits the surface of the wood or sponge, the kinetic energy is transferred to sound and heat energy.</i></p>	1

2	(a)	(i)	<p>Halaju ialah kadar perubahan sesaran <i>Velocity is the rate of change of displacement</i></p>	1
		(ii)	<p>Peluru dan senapang, penumpang dan kapal bergerak ke arah yang bertentangan. <i>The bullet and the rifle, the passenger and the boat, move in opposite directions.</i></p>	1

		Objek dengan jisim kecil (peluru atau penumpang) bergerak dengan halaju besar dibandingkan dengan objek dengan jisim besar (senapang atau bot) <i>An object with a small mass (the bullet or the passenger) moves with a large velocity compared with an object with a big mass (the rifle or the boat)</i>	1
		Peluru dan senapang serta penumpang dan kapal bergerak ke arah yang bertentangan sehingga jumlah momentum dikekalkan sifar <i>The bullet and the rifle and the passenger and the boat, move in opposite directions so that the final total momentum of the system will be maintained as zero.</i>	1
		$m_1v_1 = m_1v_2$ or $m_1v_1 - m_1v_2 = 0$ Konsep fizik: Prinsip pengabadian momentum <i>Physics concept: the Principle of conservation of momentum</i>	1
	(b)	Permukaan konkrit yang keras menghasilkan tempoh hentaman yang pendek. <i>The hard surface of the concrete floor results in a short impact time.</i>	1
		Daya impuls yang dihasilkan adalah besar untuk memecahkan cawan kaca. <i>The impulsive force produced is a big enough to break the porcelain cup</i>	1
		Permukaan karpet yang lembut dapat meningkatkan tempoh hentaman. <i>The soft surface of the carpet increases the time of impact.</i>	1
		Keadaan ini mengurangkan daya impuls yang dikenakan pada cawan kaca. Maka cawan kaca tidak pecah. <i>This reduces the impulsive force acting on the porcelain cup. The cup does not break.</i>	1

3	(a)	(i)	Daya ialah tarikan atau tolakan <i>Force is a push or pull</i>	1
		(ii)	lanya bergerak ke hadapan <i>They move forward</i>	1
			la melepaskan sesuatu untuk pergerakan, belon tersebut melepaskan udara sementara sotong melepaskan isipadu dakwat hitam yang banyak. <i>They release something for motion, the balloon releases air while the cuttlefish releases a big volume of black ink</i>	1

		<p>Belon yang bergerak ke hadapan mempunyai momentum yang sama dengan udara yang dilepaskan daripada bukaannya. Sotong bergerak ke hadapan mempunyai momentum yang sama dengan dakwat hitam yang dilepaskan olehnya.</p> <p><i>The balloon forward has an equal momentum as the air releasing from its mouth. The cuttlefish moving forward has an equal momentum as the black ink releasing by it</i></p> <p>Jumlah momentum di dalam sistem tertutup adalah tetap.</p> <p><i>The total momentum in a closed is constant</i></p> <p>Prinsip keabadian momentum</p> <p><i>Principle of conservation of momentum</i></p>	<p>1</p> <p>1</p> <p>1</p>
	(b)	<p>Kayu hoki diperbuat daripada kayu keras sementara kayu golf diperbuat daripada aloi yang keras.</p> <p><i>Hockey sticks are made of hard wood while golf clubs are made of hard alloy</i></p> <p>Permukaan keras akan memendekkan masa sentuhan kayu itu dengan bola. Maka, daya impuls menjadi tinggi dan bola dapat melantun dengan jauh,</p> <p><i>The hard surface will shorten the time of contact of the stick with the ball. Hence, the impulsive force is big and the ball is able to travel a far distance.</i></p> <p>Penghentam cerucuk diperbuat daripada aloi besi yang kuat</p> <p><i>A piledriver is made of hard steel alloy.</i></p> <p>Semasa menghentam cerucuk, penghentam cerucuk itu dilepaskan dengan sangat laju untuj mengetuk cerucuk yang keras itu. Maka masa hentaman cerucuk menjadi pendek dan menghasilkan daya impuls yang besar.</p> <p><i>While hitting the pile, the pile driver is released very fast to hit the hard pile. Hence the time taken to hit the pile is short and a big impulsive force is produced.</i></p>	<p>1</p> <p>1</p> <p>1</p> <p>1</p>

## BAB 3 : KEGRAVITIAN / CHAPTER 3 : GRAVITATION

### BAHAGIAN A / SECTION A

Soalan Question	Skema Pemarkahan Marking Scheme	Markah Marks
1	(a) Halaju lepas dan halaju linear <i>Escape velocity and linear velocity</i>	1
	$F = \frac{GMm}{r^2}$ $F = \frac{mv^2}{r}$ $\frac{mv^2}{r} = \frac{GMm}{r^2}$ $v = \sqrt{\frac{GM}{r}}$	1  1  1
	(c) $E_k = \frac{1}{2}mv^2$ $E_k + U = 0$ $\frac{1}{2}mv^2 = \frac{GMm}{r}$ $v = \sqrt{\frac{2GM}{r}}$	1  1  1
	(d)(i) $v = \sqrt{\frac{2(6.673 \times 10^{-11})(95 \times 5.97 \times 10^{24})}{\frac{1}{2}(120536000)}}$ $v = 35438.97 \text{ m s}^{-1}$	1  1
	(d)(ii) Boleh. Halaju roket melebihi halaju lepas Planet S. <i>Yes. Rocket's velocity is more than Planet S's escape velocity</i>	2

<b>2</b>	(a)	Daya graviti <i>Gravitational force</i>	1
	(b)(i)	$v = \sqrt{\frac{(6.67 \times 10^{-11}) \times (5.97 \times 10^{24})}{6.37 \times 10^6 + 1.5 \times 10^6}}$ $v = 7113.16 \text{ m s}^{-1}$	1 1
	(b)(ii)	$v = \sqrt{\frac{(6.67 \times 10^{-11}) \times (5.97 \times 10^{24})}{6.37 \times 10^6 + 6.2 \times 10^5}}$ $v = 7547.65 \text{ m s}^{-1}$	1 1
	(c)(i)	Jarak satelit A adalah lebih besar daripada satelit B <i>Distance of Satellite A is greater than Satellite B</i>	1
	(c)(ii)	Laju linear satelit A lebih kecil daripada B <i>Linear velocity of Satellite A is lower than Satellite B</i>	1
	(c)(iii)	Semakin besar jarak satelit dari pusat Bumi, semakin rendah laju linearnya. <i>The greater the satellite distance from Earth center, the lower the linear velocity</i>	1
	(d)	Arah gerakan satelit A sama dengan arah putaran Bumi. <i>The direction of Satellite A is the same as Earth's rotation</i>	1
		Tempoh putaran satelit A ialah 24 jam. <i>The rotation period of Satellite A is 24 hours</i>	1
	(e)	Satelit A akan jatuh ke dalam orbit lebih dekat dengan Bumi. <i>Satellite A will drop to an orbit closer to earth</i>	1
	Daya memusat menjadi lebih rendah daripada daya gravity Bumi ke atas satelit A di orbit asalnya. <i>The centripetal force becomes lower than Earth's gravitational force towards Satellite A in it's initial orbit</i>	1	

**BAHAGIAN B DAN C / SECTION B AND C**

Soalan Question	Skema Pemarkahan Marking Scheme	Markah Marks
1	(a) Daya graviti ialah daya yang bertindak antara mana-mana dua jasad dalam alam semesta. Oleh itu, daya ini dikenali sebagai daya semesta. <i>Gravitational force is the force acting between two bodies in the universe. Known as universal force.</i>	1
	(b)(i) $F = \frac{Gm_1m_2}{r^2}$ $F = \frac{(6.67 \times 10^{-11})(200)(200)}{25^2}$ $F = 4.2688 \times 10^{-9}N$	1 1
	(b)(ii) $F = \frac{Gm_1m_2}{r^2}$ $F = \frac{(6.67 \times 10^{-11})(200)(200)}{55^2}$ $F = 8.8198 \times 10^{-10}N$	1 1
	(b)(iii) Daya graviti dalam Rajah 1.1 lebih besar berbanding Rajah 1.2 <i>Gravitational force in Diagram 1.1 is greater than Diagram 1.2</i>	1
	(b)(iv) Jarak antara pusat objek berkadar songsang dengan daya graviti <i>Distance between the center of an object is inversely proportional towards the gravitational force</i>	1
	(c)(i) $F = \frac{Gm_1m_2}{r^2}$ $F = \frac{(6.67 \times 10^{-11})(200)(200)}{30^2}$ $F = 2.964 \times 10^{-9}N$	1 1
	(c)(ii) $F = \frac{Gm_1m_2}{r^2}$ $F = \frac{(6.67 \times 10^{-11})(100)(100)}{30^2}$ $F = 7.411 \times 10^{-10}N$	1 1
	(c)(iii) Daya graviti dalam Rajah 1.3 lebih besar berbanding Rajah 1.4 <i>Gravitational force in Diagram 1.3 is greater than Diagram 1.4</i>	1
	(c)(iv) Jisim objek berkadar langsung dengan daya graviti <i>Object mass is directly proportional to the gravitational force</i>	1
	(d) Jisim Bumi, <i>Earth's mass</i> = $5.97 \times 10^{24}kg$ Jejari Bumi, <i>Earth's radius</i> = $6.37 \times 10^6m$	

	<p>Sebelum pelancaran:  <i>Before launch :</i></p> <p>Jisim satelit, <i>Satellite's mass</i> = <math>1.55 \times 10^3 \text{ kg}</math></p> <p>Jarak di antara satelit dengan pusat Bumi, <i>Satellite and Earth's distance</i>  = <math>6.37 \times 10^6 \text{ m}</math></p> <p>Daya graviti, <i>Gravitational force</i></p> $F = \frac{Gm_1m_2}{r^2}$ $F = \frac{(6.67 \times 10^{-11})(5.97 \times 10^{24})(1.55 \times 10^3)}{(6.37 \times 10^6)^2}$ $F = 15210.83 \text{ N}$	1  1
	<p>Selepas pelancaran:  <i>After launch :</i></p> <p>Jisim satelit, <i>Satellite's mass</i> = <math>1.55 \times 10^3 \text{ kg}</math></p> <p>Jarak di antara satelit dengan pusat Bumi, <i>Satellite and Earth's distance</i> =  <math>3.8 \times 10^7 \text{ m}</math></p> <p>Daya gravity, <i>Gravitational force</i></p> $F = \frac{Gm_1m_2}{r^2}$ $F = \frac{(6.67 \times 10^{-11})(5.97 \times 10^{24})(1.55 \times 10^3)}{(3.87 \times 10^6)^2}$ $F = 41210.69 \text{ N}$	1  1  1
	<p>Daya graviti sebelum pelancaran adalah lebih besar daripada bila satelit itu berada dalam orbit.  <i>Gravitational force before launch is bigger than while the satellite is in orbit.</i></p>	

## BAB 4 : HABA / CHAPTER 4 : HEAT

### BAHAGIAN A / SECTION A

Soalan Question	Skema Pemarkahan Marking Scheme	Markah Marks
<b>1</b>	(a) (i) $1.2 > 1.1$ (ii) $1.2 > 1.1$ (iii) Sama / Equal	1 1 1
	(b) Suhu udara terperangkap bertambah, kuantiti fizikal yang diukur Tolok Bourdon bertambah <i>Temperature of the air trapped increases, the physical quantity measured by the Bourdon gauge increases</i>	1
	(c) Tenaga kinetik bertambah / bergerak laju <i>Kinetic energy / velocity increase / move faster</i>	1
	Kadar perlanggaran bertambah <i>rate of collision increase</i>	1
<b>2</b>	(a) (i) $2.2 > 2.1$ (ii) $2.2 > 2.1$	1 1
	(b) (i) haba yang dibekalkan bertambah, isipadu udara yang terperangkap bertambah <i>heat supplied increases, volume of air trapped increases</i>	1
	(ii) suhu bertambah, isipadu udara yang terperangkap dalam tiub kapilari bertambah <i>temperature increases, the volume of air trapped in the capillary tube increases</i>	1
	(c) Tenaga kinetik bertambah / bergerak laju <i>Kinetic energy / velocity increase / move faster</i>	1
	Kadar perlanggaran bertambah <i>rate of collision increase</i>	1

**BAHAGIAN B DAN C / SECTION B AND C**

Soalan Question	Skema Pemarkahan Marking Scheme	Markah Marks
<b>1</b>	<p>(a) Jisim cecair B lebih besar dari jisim cecair A <i>Mass of liquid in the beaker B greater than mass of liquid in beaker A</i></p> <p>Kenaikan suhu pada bikar A lebih besar dari kenaikan suhu pada bikar B <i>The rise of the temperature in the beaker A greater than B</i></p> <p>Muatan haba tentu bikar A dan B adalah sama <i>Specific heat capacity of beaker A and B are the same</i></p> <p>Jumlah haba yang dibekalkan pada bikar A dan B adalah sama <i>Total heat supplied for beaker A and B are the same</i></p> <p>Semakin besar jisim, semakin kecil kenaikan suhu <i>Mass increase , the rise of temperature decrease</i></p>	<p>1</p> <p>1</p> <p>1</p> <p>1</p> <p>1</p>
<b>2</b>	<p>(a) Muatan haba tentu kualiti M lebih besar dari kualiti N <i>Specific heat capacity of frying pan M is greater than N</i></p> <p>Masa untuk mendidihkan air oleh kualiti M lebih panjang dari kualiti N <i>Time taken for the water to boil in M is longer than N</i></p> <p>Perubahan suhu dalam kualiti M dan N adalah sama <i>Change of temperature in M and N are the same</i></p> <p>Semakin besar muatan haba tentu semakin panjang masa yang diambil untuk air mendidih <i>Specific heat capacity increase, the time taken for the water to boil increase.</i></p> <p>Semakin besar muatan haba tentu, semakin kecil kadar perubahan suhu <i>Specific heat capacity increase, the rate of change of temperature decrease</i></p>	<p>1</p> <p>1</p> <p>1</p> <p>1</p> <p>1</p>
<b>3</b>	<p>(a) Isipadu udara terperangkap dalam Rajah 3.2 lebih besar dari Rajah 3.1 <i>Volume of trapped air in Diagram 3.2 is greater than Diagram 3.1</i></p> <p>Tekanan dalam Rajah 3.1 lebih besar dari Rajah 3.2 <i>Pressure in Diagram 3.1 is greater than Diagram 3.2</i></p> <p>Suhu kedua-dua adalah sama <i>Both temperatures are constant</i></p> <p>Semakin tinggi tekanan, semakin rendah isipadu <i>The higher the pressure, the lower the volume</i></p> <p>Hukum Boyle <i>Boyle's Law</i></p>	<p>1</p> <p>1</p> <p>1</p> <p>1</p> <p>1</p>

## BAB 5 : GELOMBANG / CHAPTER 5 : WAVES

### BAHAGIAN A / SECTION A

Soalan Question	Skema Pemarkahan Marking Scheme	Markah Marks
<b>1</b>	(a) A - Sinar-X <i>X-ray</i> B - Sinar infra-merah <i>Infrared ray</i>	1  1
	(b) Mana-mana satu <i>Any one</i> <ul style="list-style-type: none"> <li>• merupakan gelombang melintang <i>are transverse waves</i></li> <li>• Tidak memerlukan medium perambatan <i>do not need medium for propagation</i></li> <li>• boleh merambat melalui vakum <i>can propagate through vacuum</i></li> <li>• Laju dalam vakum, <math>c = 3.00 \times 10^8 \text{ m s}^{-1}</math> <i>have speed in vacuum, <math>c = 3.00 \times 10^8 \text{ m s}^{-1}</math></i></li> <li>• menunjukkan fenomena pantulan, pembiasan, pembelauan dan interferens jika keadaannya sesuai <i>show phenomena of reflection, refraction, diffraction and interference under suitable conditions</i></li> </ul>	1
	(c) A lebih kecil <i>A is smaller</i>	1
	(d) A lebih besar <i>A is bigger</i>	1
	(e) Sama <i>Same</i>	1
	(f) Inframerah <i>Infrared</i>	1

2	(a)	Rajah 2.1 lebih kecil daripada Rajah 2.2 / sebaliknya / $a_1 < a_2$ <i>Diagram 2.1 &lt; Diagram 2.2 / vice-versa / <math>a_1 &lt; a_2</math></i>	1
	(b)	Sama <i>Same</i>	1
	(c)	Sama / $D1 = D2$ <i>Same / <math>D1 = D2</math></i>	1
	(d)	Rajah 2.1 lebih besar daripada Rajah 2.2 / sebaliknya <i>Diagram 2.1 bigger than Diagram 2.2 / vice-versa</i>	1
	(e)	Jika a bertambah, x bertambah <i>When a increases, x increases</i>	1

3	(a)	Cahaya yang mempunyai satu panjang gelombang / satu warna <i>The light which has one wavelength / one colour</i>	1
	(b)(i)	Panjang gelombang cahaya merah besar berbanding panjang gelombang cahaya biru <i>Wavelength of red light is greater than wavelength of blue light</i>	1
	(b)(ii)	Jarak antara pinggir-pinggir terang berturutan bagi cahaya merah besar berbanding cahaya biru <i>Distance between consecutive bright fringes for red light is more than that of blue light</i>	1
	(c)	Semakin bertambah panjang gelombang, semakin bertambah jarak antara pinggir-pinggir terang berturutan <i>The longer the wavelength, the longer the distance between consecutive bright fringes</i>	1
	(d)(i)	Jarak antara pinggir-pinggir terang berturutan berkurang <i>The distance between two consecutive bright fringes will decrease</i>	1
	(d)(ii)	a berkadar songsang dengan x <i>a is inversely proportional to x</i>	1
	(e)	Interferens gelombang cahaya <i>Interference of light</i>	1



## BAB 6 : CAHAYA DAN OPTIK / CHAPTER 6 : LIGHT AND OPTICS

### BAHAGIAN A / SECTION A

Soalan Question	Skema Pemarkahan Marking Scheme	Markah Marks
<b>1</b>	(a) Pembiasan <i>Refraction</i>	1
	(b)(i) Dalam nyata Rajah 1.1 > Rajah 1.2 <i>Real depth Diagram 1.1 &gt; Diagram 1.2</i>	1
	(ii) Dalam ketara Rajah 1.1 > Rajah 1.2 <i>Apparent depth Diagram 1.1 &gt; Diagram 1.2</i>	1
	(iii) Semakin bertambah dalam nyata, semakin bertambah dalam ketara <i>The bigger the real depth, the bigger the apparent depth</i>	1
	(c)(i) Indeks pembiasan <i>Refractive index</i>	1
	(ii) $n = \frac{H}{h}$	1
	(iii) $n = \frac{20}{15}$ $= 1.33$	2
	(d)(i) Imej syiling kelihatan lebih dekat dengan permukaan larutan <i>Image of coin appear near to the surface of solution</i>	1
<b>2</b>	(a) Imej yang tidak dapat dibentuk pada skrin <i>Image cannot obtained on a screen</i>	1
	(b)(i) Ketebalan kanta P > Q <i>Thickness of lens P &gt; Q</i>	1
	(ii) Panjang fokus kanta P < Q <i>Focal length of lens P &lt; Q</i>	1
	(iii) Saiz imej kanta P > Q <i>Size of image of lens P &gt; Q</i>	1
	(iv) Semakin bertambah panjang fokus, semakin kecil saiz imej <i>The bigger the focal length, the smaller the size of image</i>	1
	(c) Semakin bertambah panjang fokal, semakin kecil kuasa kanta <i>The bigger the focal length, the smaller the power of lens.</i>	1

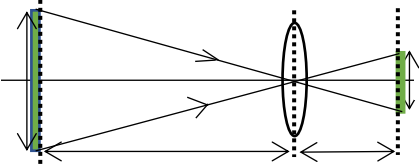
(d)(i)		2
(d)(ii)	Nyata / songsang <i>Real / inverted</i>	1

### BAHAGIAN B DAN C / SECTION B AND C

Soalan Question	Skema Pemarkahan Marking Scheme	Markah Marks
1	(a) Sudut tuju, $i$ , apabila sinar cahaya dibiaskan pada $90^\circ$ dari normal <i>Angle of incidence, <math>i</math>, when a light ray is refracted at <math>90^\circ</math> from normal</i>	1
	(b)(i) Ketumpatan kaca < intan / <i>Density of glass &lt; diamond</i> Sudut tuju kaca > intan / <i>Angle of incidence of glass &gt; diamond</i> Sudut biasan kaca = intan / <i>Refractive angle of glass = diamond</i>	1 1 1
	(ii) Sudut tuju = sudut genting, apabila sudut biasan = $90^\circ$ <i>incidence angle = critical angle, when refractive angle = <math>90^\circ</math></i>	1
	(iii) Semakin besar ketumpatan, semakin kecil sudut genting <i>The bigger the density, the smaller the critical angle</i>	1

2	(a) Titik pada paksi utama, dimana sinar cahaya selari dengan paksi utama seolah-olah tercapah dari titik ini <i>The point on the principal axis, where light ray which are parallel to the principal axis appear to diverge from this point.</i>	1
	(b) Kelengkungan permukaan cermin rajah 2.1 > 2.2 <i>Curvature of the surface of the mirror in diagram 2.1 &gt; 2.2</i> Sudut pembengkokan sinar cahaya rajah 2.1 > 2.2 <i>Angle of bending of light ray diagram 2.1 &gt; 2.2</i> Panjang fokus rajah 2.1 < 2.2 <i>Focal length diagram 2.1 &lt; 2.2</i> Semakin bertambah kelengkungan permukaan cermin, semakin bertambah sudut pembengkokan sinar cahaya <i>The bigger the curvature of mirror, the bigger the angle of bending</i> Semakin bertambah kelengkungan, semakin kecil panjang fokus <i>The bigger the curvature, the smaller the focal length</i>	1 1 1 1 1

# MEMBUAT KEPUTUSAN

## BAB 1 : PENGUKURAN / CHAPTER 1 : MEASUREMENT

### BAHAGIAN B DAN C / SECTION B AND C

Soalan Question	Skema Pemarkahan Marking Scheme			Markah Marks
1	Aspek <i>Aspects</i>	Pilihan <i>Choice</i>	Sebab <i>Reason</i>	
	Label Paksi-y <i>y-axis label</i>	Hasil kuasa dua <i>Squared value</i>	Sebab tempoh ayunan lebih jitu <i>Because the period of oscillations is more accurate</i>	1 + 1
	Skala Paksi-x <i>x-axis scale</i>	Genap <i>Even / uniform</i>	Sebab skala seragam merupakan gandaan / sifir 1, 2, 5 <i>Because uniform scale commonly use the multiplication of 1, 2, 5</i>	1 + 1
	Bilangan titik yang diplotkan dengan tepat <i>Numbers of points plotted correctly</i>	Sama dengan lima / lebih lima <i>Equal to five / more than five</i>	Sebab dapat mewakili hubungan kedua-dua pembolehubah dengan lebih tepat <i>Because it can represent the relationship of both variables correctly</i>	1 + 1
	Luas graf yang dilukis di atas kertas graf <i>Size of graph drawn on graph paper</i>	Lebih 50% <i>More than 50%</i>	Sebab graf lebih tepat jika saiz besar <i>Because graph is more accurate with large size</i>	1 + 1
	Pelajar yang dipilih: <i>Selected student</i>	Pelajar C <i>Student C</i>	Sebab pelajar C mempunyai label paksi-y ialah hasil kuasa dua, skala paksi-x genap, bilangan titik yang diplotkan sama dengan lima, dan saiz graf lebih 50%. <i>Because Student C have squared value on y-axis label, even / uniform x-axis scale, equal to five or more numbers of points plotted correctly, and more than 50% size of graph drawn on graph paper.</i>	1 + 1



	Prinsip keabadian momentum menyatakan bahawa jumlah momentum perlanggaran diantara dua objek adalah sama sebelum dan selepas perlanggaran. <i>The Principle of Conservation of Momentum states that in a collision between two objects the total momentum of the objects in the system remains unchanged.</i>	1
	Momentum bola pertama dipindahkan ke bola kedua dan kepada bola-bola yang seterusnya. <i>The momentum from the first ball is transferred to the second ball and then transmitted through the balls at rest to the ball on the other end</i>	1 Max 2
(c)	Keluli	1
(i)	Steel Memendekkan masa pelanggaran/momentum tinggi <i>Shorten the time impact/ high momentum</i>	1
(ii)	Dua tali digunakan untuk menggantung bola <i>Two strings used to hang each ball</i> Memastikan bola bergerak dalam satu arah sahaja <i>This string arrangement restricts the balls' movement to the same plane.</i>	1 1
(d)	P	1

### BAHAGIAN B DAN C / SECTION B AND C

Soalan Question	Skema Pemarkahan Marking Scheme		Markah Marks
1	Spesifikasi <i>Specification</i>	Sebab <i>Reason</i>	1 + 1  1 + 1  1 + 1
	Jenis brek ABS <i>The type of brakes is ABS</i>	ABS adalah lebih berkesan daripada brek udara kerana lori boleh berhenti dengan serta merta dan tidak menggelincir <i>ABS is more effective than air brake because the lorry can be stopped immediately and does not slip</i>	
	Bilangan tayar 2 atau banyak <i>The number of tyres 2 or more</i>	Memberi sokongan yang lebih baik/ tekanan lebih rendah bertindak ke atas tayar <i>Provides better support/ lower pressure acts on the tyres</i>	
	Bilangan tangki 5 dan saiz kecil <i>The number of tanks is 5 and small in size</i>	5 tangki kecil dimana jisim muatan dibahagi antara tangki-tangki tersebut akan mempunyai inersia yang lebih kecil. Ini dapat mengurangkan impak inersia pada setiap tangki disebabkan oleh inersia jika lori tangki berhenti dengan tiba-tiba.	

		<i>5 small tanks with distributed mass will have smaller inertia. This greatly reduces the inertial impact on each tank if the tanker stops suddenly.</i>	
	Jarak antara treler dan kepala lori jauh <i>The distance between the trailer and the tractor is further</i>	Dapat mengelakkan pelanggaran di antara treler dengan kepala lori <i>Prevent collision between the trailer and the tractor</i>	1 + 1
	Lori tangki <b>R</b> dipilih. Kerana ia mempunyai sistem brek ABS, dua tayar, 5 tangki kecil dan jarak di antara treler dan kepala lori lebih besar. <i>Tanker R is chosen. Because it has an ABS brake system, two tyres, 5 small tanks and longer distance between the trailer and the tractor.</i>		1 + 1

<b>2</b>	<b>Ciri-ciri</b> <i>Characteristic</i>	<b>Sebab</b> <i>Reason</i>	
	Jisim yang lebih kecil <i>Smaller mass</i>	Pecutan yang lebih tinggi <i>Higher acceleration</i>	1 + 1
	Masa tindak balas pendek <i>Shorter reaction time</i>	Pecutan maksimum boleh dicapai dalam masa yang lebih singkat <i>Maximum acceleration can be reached in a shorter time.</i>	1 + 1
	Jarak membrek lebih pendek <i>Shorter braking distance</i>	Boleh dihentikan dalam masa yang lebih pendek <i>Can be stopped in a shorter time</i>	1 + 1
	Tayar tidak berbunga <i>Tyres without tread patterns</i>	Permukaan sentuhan yang besar dengan jalan dan meningkatkan pecutan <i>Larger contact with the surface which increases the acceleration</i>	1 + 1
	Kereta <b>C</b> dipilih. Kerana kereta C mempunyai jisim lebih kecil, masa tindak balas lebih pendek, jarak membrek lebih pendek dan tayar tanpa bunga. <i>Car C is chosen. Car C has smaller mass, shorter reaction time, shorter braking distance and tyres without tread patterns.</i>		1 + 1

## BAB 3 : KEGRAVITIAN / CHAPTER 3 : GRAVITATION

### BAHAGIAN B DAN C / SECTION B AND C

Soalan Question	Skema Pemarkahan Marking Scheme		Markah Marks
1	Lokasi berubah pada masa yang berlainan <i>Position is at different location at different times</i>	Memperoleh bacaan berlainan daripada lokasi berlainan <i>Able to obtain readings from different locations</i>	1 + 1
	Tempoh orbit lebih kecil dari 24 jam <i>Orbital period is shorter than 24 hours</i>	Memperoleh bacaan berlainan daripada lokasi berlainan <i>Able to obtain readings from different locations</i>	1 + 1
	Arah orbit satelit berbeza daripada putaran Bumi <i>Direction of satellite orbit is different than Earth's rotation</i>	Memperoleh bacaan berlainan daripada lokasi berlainan <i>Able to obtain readings from different locations</i>	1 + 1
	Orbit satelit lebih rendah daripada Orbit Bumi Geopegun <i>Orbit of the satellite is lower than the GEO</i>	Memperoleh bacaan berlainan daripada lokasi berlainan <i>Able to obtain readings from different locations</i>	1 + 1
	Satelit B <i>Satellite B</i>	Lokasi berubah pada masa yang berlainan, tempoh orbit lebih kecil dari 24 jam, arah orbit satelit berbeza daripada putaran bumi dan orbit satelit lebih rendah daripada Orbit Bumi Geopegun <i>Position is at different location at different times, Orbital period is shorter than 24 hours, Direction of satellite orbit is different than Earth's rotation and Orbit of the satellite is lower than the GEO</i>	1 + 1

2	<b>Ciri-ciri</b> <b>Characteristics</b>	<b>Penerangan</b> <b>Reason</b>	
	Tempoh orbit 24 jam <i>Orbital period 24 hours</i>	Sama dengan tempoh putaran lengkap Bumi. <i>Same with the complete period of Earth rotation</i>	1 + 1
	Arah edaran Barat ke Timur <i>Direction of orbit from West to east</i>	Arah putaran sama dengan arah putaran Bumi. <i>The direction of rotation is the same as the direction of rotation of the Earth.</i>	1 + 1
	Bilangan satelit = 3 <i>Number of satellites = 3</i>	Memastikan gelombang penyiaran sampai ke seluruh dunia. <i>Ensure the broadcast reaches the whole world.</i>	1 + 1
	Satelit X <i>Satellite X</i>	Tempoh orbit 24 jam <i>Orbital period 24 hours</i> Arah edaran Barat ke Timur <i>Direction of orbit from West to east</i> Bilangan satelit = 3 <i>Number of satellites = 3</i>	1 + 1

## BAB 4 : HABA / CHAPTER 4 : HEAT

### BAHAGIAN A / SECTION A

Soalan Question	Skema Pemarkahan Marking Scheme	Markah Marks
<b>1</b>	(a)(i) Plastik berongga <i>Hollow plastics</i> Mengelakkan haba keluar daripada kelalang termos <i>Prevents heat from escaping the thermos flask</i>	1  1
	(ii) Vakum <i>Vacuum</i> Mengurangkan kehilangan haba melalui pengaliran <i>Less heat will be lost through conduction</i>	1  1
	(iii) Kaca <i>Glass</i> Untuk mengelakkan haba dipindah keluar daripada kelalang termos melalui pengaliran dan perolakan. <i>To prevent heat transferred out of the flask through conduction and convection</i>	1  1
	(b) Q	1
<b>2</b>	(a) $C_{\text{seramik}} = (180)(10 \times 60)(2 \times 60)$ $= 900 \text{ J / kg } ^\circ\text{C}$ $C_{\text{kaca}} = (70)(15 \times 60)(2 \times 60)$ $= 525 \text{ J / kg } ^\circ\text{C}$	1  1
	(b) P Muatan haba tentu yang tinggi akan mengekalkan haba untuk jangka masa yang lebih lama <i>High specific heat capacity will maintain heat for a longer period</i>	1  1

**BAHAGIAN B DAN C / SECTION B AND C**

<b>Soalan Question</b>	<b>Skema Pemarkahan Marking Scheme</b>		<b>Markah Marks</b>	
<b>1</b>	<b>Ciri-ciri Characteristics</b>	<b>Penerangan Explanation</b>		
	Haba pendam tentu agen penyejuk yang tinggi <i>High specific latent heat of cooling agent</i>	Menyerap lebih banyak haba <i>Absorb more heat</i>		1 + 1
	Takat didih agen penyejuk yang tinggi <i>High boiling point of cooling agent</i>	Tidak mudah bertukar fasa <i>Not easy to change phase</i>		1 + 1
	Paip mengalir berdiameter besar <i>Large diameter of conducting pipe</i>	Mengisi lebih banyak cecair <i>Accommodate more liquid</i>		1 + 1
	Muatan haba tentu paip pengalir yang rendah <i>Low specific heat capacity of conducting pipe</i>	Tidak mudah menjadi panas <i>Not easy to get hot</i>		1 + 1
	<b>C</b> dipilih <i>C is chosen</i>			1
	Mempunyai haba pendam tentu yang tinggi dan takat didih yang tinggi, dan paip pengalir berdiameter besar dan muatan haba tentu yang rendah. <i>Its cooling agent has high specific latent heat and high boiling point, and conducting pipe has large diameter and low specific heat capacity.</i>			1

<b>2</b>	<b>Ciri-ciri</b> <i>Characteristics</i>	<b>Penerangan</b> <i>Explanation</i>	
	Ada penutup kaca <i>Have glass cover</i>	Mengurangkan kehilangan haba <i>Reduces heat loss</i>	1 + 1
	Panel hitam <i>Black panel</i>	Menyerap lebih banyak haba daripada matahari <i>Absorbs more heat from sun</i>	1 + 1
	Banyak gegelung paip <i>More pipe coils</i>	Luas permukaan yang lebih besar untuk pemindahan haba <i>Bigger surface area of heat transfer</i>	1 + 1
	Muatan haba tentu paip air rendah <i>Low specific heat capacity of water pipes</i>	Cepat/ mudah memindahkan haba <i>Transfer heat faster/easy to get hot</i>	1 + 1
	<p>Pemanas solar <b>Q</b> <i>Solar heater Q</i></p> <p>Mempunyai penutup kaca, panel hitam, gegelung paip yang banyak dan muatan haba tentu paip air yang rendah. <i>Have glass cover, black panel, more pipe coils and low specific heat capacity of water pipes.</i></p>		1

## BAB 5 : GELOMBANG / CHAPTER 5 : WAVES

### BAHAGIAN A / SECTION A

Soalan Question	Skema Pemarkahan Marking Scheme	Markah Marks
<b>1</b>	(a) Gelombang ultrasonic <i>Ultrasonic wave</i> Sesuai untuk mengesan / memetakan organ dalaman <i>Suitable to detect internal organ</i>	1  1
	(b) Panjang gelombang yang lebih panjang digunakan <i>Longer wavelength is used</i> Mengurangkan pembelauan dan menambah pantulan gelombang <i>Cut down diffraction and increase reflection</i>	1  1
	(c) Amplitud gelombang yang tinggi <i>Higher amplitude</i> Lebih banyak tenaga dapat dipantulkan <i>More energy can be reflected</i>	1  1
	(d) Pantulan <i>Reflection</i> Guna intensiti pantulan berbeza untuk menunjukkan / memetakan bentuk organ <i>Use different intensity of reflection to map out the shape of the organ</i>	1  1
	(e) E	1
<b>2</b>	(a) Di hadapan mikrofon <i>In front of the microphone</i> Elakkan gangguan bunyi / untuk mengelakkan bunyi daripada pembesar suara dikuatkan lagi oleh mikrofon <i>Avoid disturbance / to prevent the sound from speakers being amplified again by the microphones</i>	1  1
	(b) Jauh daripada satu sama lain <i>Further distance between the speakers</i> Meningkatkan medan penyebaran bunyi / mengurangkan titik nod bunyi terhasil akibat daripada interferens pemusnah <i>Reducing the nodal points of sound resulting from destructive interference</i>	1  1

3	(a)	gelombang elektromagnet <i>electromagnetic waves</i> dapat merambat melalui vakum <i>because they can propagate through vacuum.</i>	1  1
	(b)	Laju sangat tinggi <i>very high speed</i> supaya maklumat yang dipancar dan diterima serta merta <i>informations can be transmitted and received almost immediately</i>	1  1
	(c)	tidak bahaya <i>Not harmful</i> tidak akan mendatangkan kesan buruk kepada pengguna <i>it will not cause any harmful side effect to the user</i>	1  1
	(d)	R adalah paling sesuai <i>most suitable is R</i>	1

### BAHAGIAN B DAN C / SECTION B AND C

Soalan Question	Skema Pemarkahan Marking Scheme		Markah Marks
1	Ciri – ciri <i>Characteristic</i>	Penerangan <i>Explanantion</i>	
	Jenis sinar: Gelombang radio <i>Type of ray: Radio waves</i>	Mudah dibelaukan//tidak mudah terhalang <i>Easily diffract // not easily obstructed</i>	1 + 1
	Jarak kunci dari kereta: Jauh <i>Key distance from the car: Far</i>	Pintu kereta mudah dibuka dari jauh <i>Car doors are easily open from the distance</i>	1 + 1
	Keselamatan kepada pengguna: Tiada kesan <i>Safety for consumers: No effect</i>	Tidak memudaratkan pengguna <i>Not harmful to the consumers</i>	1 + 1
	Sumber gelombang: Gelombang elektromagnet <i>Waves source: Electromagnetic waves</i>	Mempunyai julat yang besar <i>Has a large range</i>	1 + 1

	<p>Sistem pengesanan yang sesuai ialah sistem pengesanan <b>N</b> sebab jenis sinar adalah gelombang radio, jarak kunci dari kereta jauh, tiada kesan kepada pengguna dan sumber gelombang adalah gelombang elektromagnet.</p> <p><i>The suitable detecting system is Detecting System <b>N</b> because the type of ray is radio waves, the key distance is far from the car, it has no effect on consumers and the wave source is electromagnetic waves</i></p>	1 + 1
--	------------------------------------------------------------------------------------------------------------------------------------------------------------------------------------------------------------------------------------------------------------------------------------------------------------------------------------------------------------------------------------------------------------------------------------------------------------------	-------

<b>Soalan</b> <b>Question</b>	<b>Skema Pemarkahan</b> <b>Marking Scheme</b>	<b>Markah</b> <b>Marks</b>
<b>2</b>	Saiz celah: Kecil <i>Size of gap: Small</i>	1
	Sebab: mengurangkan amplitud / tenaga / kesan pembelauan lebih ketara <i>Reason: reduce amplitude / energy / diffraction more obvious</i>	1
	Ketinggian benteng: Tinggi <i>Height of retaining wall: High</i>	1
	Sebab: menahan ombak yang tinggi <i>Reason: block high wave</i>	1
	Bahan yang digunakan untuk benteng: konkrit <i>Material used for the retaining wall: concrete</i>	1
	Sebab: lebih kuat / tahan hentaman <i>Reason: stronger / withstand high impact</i>	1
	Ketebalan dinding: Tinggi <i>Thickness of wall: High</i>	1
	Sebab: tahan lasak / tidak mudah pecah <i>Reason: durable / not easily broken</i>	1
	<b>S</b> Mempunyai Saiz celah yang kecil, bahan diperbuat daripada konkrit, struktur yang tinggi dan tebal.	1
	<i>Has a small gap size, the material is made of concrete, high and thick structure.</i>	1

Soalan Question	Skema Pemarkahan Marking Scheme	Markah Marks
3	Ditempatkan di teluk <i>Located at the bay</i>	1
	Tenaga gelombang berkurang / lebih tenang / amplitud gelombang lebih kecil <i>Wave energy decreases / calmer / smaller amplitude waves</i>	1
	Bercerun <i>Sloping</i>	1
	Laju / amplitud / panjang gelombang / tenaga bagi gelombang air berkurang apabila kedalaman berkurang <i>Speed / amplitude / wavelength / energy of the water wave decreases when the depth decreases.</i>	1
	Permukaan tidak rata <i>Uneven surface</i>	1
	Untuk mengurangkan tenaga. <i>To reduce energy</i>	1
	Tembok penahan yang tinggi <i>High retaining wall</i>	1
	Untuk melindungi pelabuhan daripada gelombang tinggi <i>To protect harbour from high waves</i>	1
	<b>W</b> dipilih. <b>W</b> is chosen.	1
	Kerana ia ditempatkan di teluk, bercerun, mempunyai permukaan tak rata dan adalah tinggi. <i>Because it is located at a bay, is sloping, has uneven surface, and is high</i>	1

## BAB 6 : CAHAYA DAN OPTIK / CHAPTER 6 : LIGHT AND OPTICS

### BAHAGIAN A / SECTION A

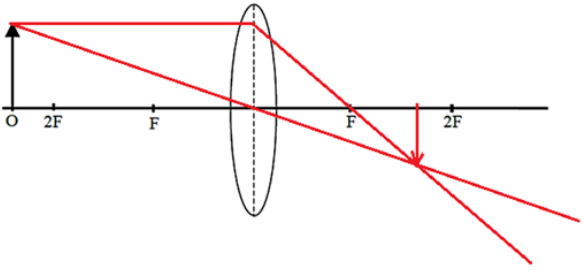
Soalan Question	Skema Pemarkahan Marking Scheme	Markah Marks
<b>1</b>	(a) Jarak antara titik fokus dan pusat optik <i>Distance between the focal point and the optical centre</i>	1
	(b)(i) 	1
	(ii) Nyata / songsang / diperkecilkan <i>Real / inverted / diminished</i>	1
	(c)(i) Kanta cembung <i>Convex lens</i> Menghasilkan imej yang diperbesar / nyata <i>To produced magnified / real image</i>	1 1
	(ii) Lebih panjang <i>Longer</i> Pembesaran lebih tinggi <i>Higher magnification</i>	1 1
	(iii) Diameter lebih besar <i>Bigger diameter</i> Imej lebih terang / mengumpul lebih banyak cahaya <i>Brighter image / collect more light</i>	1 1
	(d) P	1
	<b>2</b>	(a) $n = \frac{1}{\sin c}$ $1.5 = \frac{1}{\sin c}$ $c = 41.81^\circ$

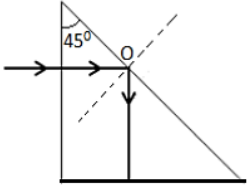
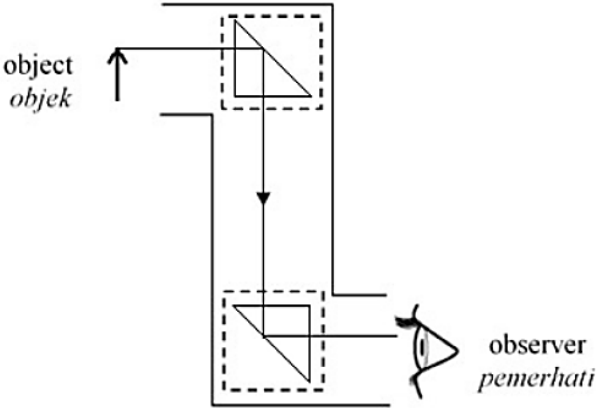
(b)(i)		1
(ii)	Pantulan dalam penuh <i>Total internal reflection</i>	1
(c)	 <p>Kedudukan dua prisma yang betul  Pantulan dalam penuh berlaku dua kali</p>	1 2
(d)(i)	Indeks biasan tinggi <i>High refractive index</i> Sudut genting kecil / pantulan dalam penuh mudah berlaku <i>Small critical angle / easy for total internal reflection occur</i>	1 1
(ii)	Saiz prisma besar <i>Bigger size of the prism</i> Menerima lebih banyak cahaya / imej lebih terang <i>Receive more light / brighter image</i>	1 1
(e)	P	1

**BAHAGIAN B DAN C / SECTION B AND C**

Soalan Question	Skema Pemarkahan Marking Scheme		Markah Marks
<b>1</b>	Ciri-ciri <i>Characteristics</i>	Penjelasan <i>Explanation</i>	
	Menggunakan kanta cembung <i>Use convex lens</i>	Sinar cahaya menumpu <i>The light ray is converging</i>	1 + 1
	Panjang fokus kanta objek besar <i>Focal length of objective lens is big</i>	Untuk menghasilkan imej yang lebih besar <i>To produce bigger image.</i>	1 + 1
	Kuasa kanta besar <i>Power of lens is big</i>	Untuk menghasilkan pembesaran yang lebih besar <i>To produce bigger magnification of image.</i>	1 + 1
	Diameter kanta objek besar <i>Diameter of objective lens is big</i>	Mengumpulkan lebih banyak cahaya supaya imeh lebih terang dan jelas <i>Collects more lights so that the image is brighter and clearer.</i>	1 + 1
	Teleskop <b>S</b> dipilih <i>Telesope <b>S</b> is chosen</i>	Kerana menggunakan kanta cembung, panjang fokus kanta objek besar, kuasa kanta besar dan diameter kanta objek besar <i>It uses convex lens, focal length of the objective lens is long, power of the lens is big and the diameter of the objective lens is big.</i>	1 + 1

Soalan Question	Skema Pemarkahan Marking Scheme		Markah Marks	
2	Ciri-ciri <i>Characteristics</i>	Penjelasan <i>Explanation</i>		
	Cermin cembung <i>Convex mirror</i>	Medan pandangan lebih luas / Cahaya boleh dipantulkan pada sudut yang lebih besar ke dalam mata pemerhati <i>Wider field of view / Light can be reflected at large angle into the observer's eye</i>		1 + 1
	Berat yang rendah <i>Low weight</i>	Lebih ringan dan mudah dilekatkan pada dinding. <i>Lighter and easier to be fixed to the wall.</i>		
	Diameter besar <i>Large diameter</i>	Memberikan medan pandangan yang lebih luas. <i>Provides wider field of view</i>		1 + 1
	Jejari kelengkungan besar <i>Long radius curvature</i>	Diameter lebih besar / Medan penglihatan lebih luas. <i>Bigger diameter / Wider field of view.</i>		1 + 1
	Kanta L dipilih <i>Lens L is chosen</i>	Kanta L dipilih kerana ia adalah cermin cembung, berat yang rendah, mempunyai diametere besar dan panjang fokus yang pendek. <i>Lens L is chosen because it is a convex mirror, has low weight, large diameter and short focal length.</i>		1 + 1
1 + 1				

# MENYELESAIKAN MASALAH

## BAB 2 : DAYA DAN GERAKAN I / CHAPTER 2 : FORCE AND MOTION I

### BAHAGIAN A / SECTION A

Soalan Question	Skema Pemarkahan Marking Scheme		Markah Marks	
<b>1</b>	(a)	Kuantiti vektor <i>Vector quantity</i>	1	
	(b)	(i)	OA: $a = \frac{15}{15} = 1 \text{ m s}^{-1}$  AB: $a = \frac{10}{5} = 2 \text{ m s}^{-1}$	1  1
		(ii)	OA < AB	1
	(c)	(i)	Rendah / Ringan <i>Low / Light</i>	2
		(ii)	Aerodinamik / Mengurangkan rintangan udara <i>Aerodynamic / Reduce air resistance</i>	2
		(iii)	Tinggi / Menghasilkan daya lebih besar <i>High / Produce bigger force</i>	2

<b>2</b>	(a)	(i)	$a = \frac{v-t}{t}$  $a = \frac{40-0}{20}$  $a = 2 \text{ m s}^{-2}$	1  1
		(ii)	$F = ma$  $= 4000 \times 2$  $= 8000 \text{ N}$	1  1
		(b)	(i)	Ditambah / lebih daripada 10 <i>Increases / more than 10</i>  mengurangkan tekanan yang bertindak ke atas lantai <i>To reduce the pressure exerted on the ground</i>
	(ii)		Ditambah / lebih daripada 2 <i>Increases / more than 2</i>	1

		mengurangkan kesan inersia <i>To reduce the inertia effect</i>	1
(c)	Momentum kenderaan berat bergantung pada laju <i>Momentum of a heavy vehicle depends in its speed</i>		1
	Mudah untuk mengawal arah / untuk mengurangkan daya impuls ketika pelanggaran berlaku <i>Easy to control the direction / to reduce the impulsive force when accident occurs</i>		1

### BAHAGIAN B DAN C / SECTION B AND C

Soalan Question	Skema Pemarkahan Marking Scheme		Markah Marks
1	Pengubahsuaian <i>Modification</i>	Penerangan <i>Explanation</i>	
	Bahan kuat <i>Strong material</i>	Tidak mudah pecah dalam tekanan tinggi dan semasa mendarat <i>Does not break easily in high pressure and when landing.</i>	1 + 1
	Jisim rendah <i>Small mass</i>	Ringan <i>Light</i>	1 + 1
	Aerodinamik / lurus <i>Aerodynamic / streamlined</i>	Mengurangkan rintangan udara <i>Reduce air resistance</i>	1 + 1
	Sudut pelancaran 45° <i>45° angle of launching</i>	Boleh bergerak dengan lebih jauh <i>Can travel at a further distance</i>	1 + 1
	Pasang sirip di hujung <i>Attach fins at the tail</i>	Boleh bergerak dengan lancar / lebih stabil <i>Can move smoothly / more stable</i>	1 + 1

Soalan Question	Skema Pemarkahan Marking Scheme		Markah Marks	
2	Pengubahsuaian <i>Modification</i>	Penerangan <i>Explanation</i>		
	Jisim pelantak cerucuk besar <i>Mass of the pile hummer must be large</i>	Dapat membekalkan daya yang besar untuk menanam cerucuk <i>Can produce large force to bury the pile</i>		1 + 1
	Ketinggian dari cerucuk mestilah tinggi <i>The height of the pile must be high</i>	Tenaga keupayaan tinggi <i>High potential energy</i>		1 + 1
	Pelantak cerucuk mestilah keras <i>The pile hummer must be hard</i>	Masa impak singkat <i>Short time of impact</i>		1 + 1
	Kuasa enjin mestilah tinggi <i>The engine power must be high</i>	Lebih banyak kerja penanaman cerucuk dapat dilakukan <i>More piling work can be done</i>		1 + 1
	Bentuk cerucuk tajam di hujung <i>Shape of the pile is sharp at the end</i>	Mudah ditenggelamkan / tekanan tinggi <i>Easy to be buried / high pressure</i>		1 + 1

## BAB 3 : KEGRAVITIAN / CHAPTER 3 : GRAVITATION

### BAHAGIAN B DAN C / SECTION B AND C

Soalan Question	Skema Pemarkahan Marking Scheme	Markah Marks	
<b>1</b>	Kedudukan di lokasi berbeza pada masa yang berbeza <i>Position is at different location at different times</i>	Boleh mengambil bacaan daripada lokasi yang berlainan <i>Able to obtain readings from different locations</i>	1 + 1
	Tempoh orbit adalah kurang daripada 24 jam <i>Orbital period is shorter than 24 hours</i>	Boleh mengambil bacaan pada masa yang berlainan <i>Able to obtain readings at different times</i>	1 + 1
	Arah orbit satelit adalah berbeza daripada arah putaran Bumi <i>Direction of satellite orbit is different than Earth's rotation</i>	Boleh mengambil bacaan daripada lokasi yang berlainan <i>Able to obtain readings from different locations</i>	1 + 1
	Orbit satelit adalah lebih rendah daripada Orbit Bumi Geopegun <i>Orbit of the satellite is lower than the Geostationary Earth Orbit</i>	Boleh mengambil bacaan daripada lokasi yang berlainan <i>Able to obtain readings from different locations</i>	1 + 1
	Bahan yang keras <i>Hard material</i>	Kuat / Tahan lama <i>Stronger / Last longer</i>	1+1
	Takat lebur tinggi <i>High melting point</i>	Tidak mudah melebur apabila memasuki atmosfera Bumi <i>Will not melt easily when entering Earth's atmosphere</i>	1 + 1

<b>2</b>	Rumus yang digunakan / <i>Formula used</i> :  Halaju Satelit / <i>Satellite's velocity</i> , $v = \sqrt{\frac{GM}{R+h}}$  Tempoh mengorbit / <i>Orbital period</i> ,  $T = \sqrt{\frac{4\pi^2 r^3}{GM}} \quad , \quad T = \sqrt{\frac{4\pi^2 (R+h)^3}{GM}}$	
----------	-------------------------------------------------------------------------------------------------------------------------------------------------------------------------------------------------------------------------------------------------------------------------------	--



## BAB 4 : HABA / CHAPTER 4 : HEAT

### BAHAGIAN A / SECTION A

Soalan Question	Skema Pemarkahan Marking Scheme		Markah Marks	
<b>1</b>	(a)	(i)	Tenaga yang dipindahkan daripada suatu objek yang panas ke objek yang sejuk / tenaga yang dipindahkan kerana terdapat perbezaan suhu. <i>The energy transferred from a hot object to a cold object / the energy transfer because of the difference in temperature</i>	1
		(ii)	Suhu dahi adalah lebih tinggi daripada suhu penyejuk gel <i>The temperature of the forehead is higher than the temperature of the pad</i>  Berlaku pemindahan haba antara dahi dan penyejuk gel sehingga suhu dahi dan gel penyejuk adalah sama <i>Heat is transferred between forehead and cooling pad until the the final temperature of forehead and cooling pad is same.</i>	1  1
	(b)	(i)	Besar <i>Big</i> Meningkatkan pemindahan haba <i>Increase transferred heat</i>	1  1
		(ii)	Muatan haba tentu tinggi <i>Higher specific heat capacity</i> Meningkatkan pengeluaran haba <i>Increase removal heat</i>	1  1
	<b>2</b>	(a)	Darjah kepanasan suatu objek <i>The degree of hotness of an object</i>	1
		(b)	(i)	Polistirena <i>Polystyrene</i> Penebat haba yang baik <i>Good heat insulator</i>
(ii)			Tinggi <i>High</i> Tidak mudah menyerap haba daripada sekeliling <i>Does not easily absorb heat from surrounding</i>	1  1

	(iii)	Tebal <i>Thick</i> Haba dari luar tidak mudah masuk <i>Heat from outside does not enter easily</i>	1    1
--	-------	-------------------------------------------------------------------------------------------------------------	--------------------

**BAHAGIAN B DAN C / SECTION B AND C**

Soalan Question	Skema Pemarkahan Marking Scheme		Markah Marks
1	Ciri – ciri <i>Characteristic</i>	Penerangan <i>Explanation</i>	
	Jenis cecair digunakan ialah merkuri <i>Type of liquid used is mercury</i>	Takat didih tinggi <i>High boiling point</i>	1 + 1
	Cecair yang mempunyai takat didih tinggi <i>The liquid has high boiling point</i>	Tidak mudah berubah bentuk jirim <i>Not easily change the shape of matter</i>	1 + 1
	Bahan untuk badan termometer : kaca <i>Material used for body of the thermometer is glass</i>	Tahan kakisan / Mudah dilihat <i>Corrosion resistant / Easily see</i>	1 + 1
	Diameter tiub rerambut yang kecil / halus <i>Diameter of the capillary tube is small / subtle</i>	Merkuri mudah mengembang <i>Mercury expands easily</i>	1 + 1
	Bentuk badan dari pandangan atas ialah bulat <i>Cross sectional shape of thermometer's body is round</i>	Mudah baca skala pada badan termometer <i>Easy to read the scale on the thermometer</i>	1 + 1

<b>2</b>	Ciri – ciri <i>Characteristic</i>	Penerangan <i>Explanation</i>	
	Dinding diperbuat daripada bahan lutsinar / dinding warna cerah / dinding dilapisi <i>Well made of transparent material / bright wall / tinted wall</i>	Untuk pencahayaan semulajadi / jimat tenaga / pantul cahaya/haba <i>To provide natural lighting to the shelter / save energy / reflect light / heat</i>	1+1
	Lubang udara banyak <i>More number of air holes</i>	Pengudaraan yang baik / banyak udara sejuk masuk / banyak udara panas keluar <i>Provide good ventilation / more cool air in / more hot air goes out</i>	1+1
	Bukaan yang besar <i>Big size opening</i>	Pengudaraan yang baik / cepat sejuk <i>Provide good air movement / cool faster</i>	1+1
	Bumbung terdiri daripada bahan yang mempunyai muatan haba tentu yang tinggi <i>Roof made of material of large specific high capacity</i>	Lambat panas <i>Does not heats up easily</i>	1+1
	Memasang kipas elektrik / penyaman udara <i>Install electric fans / aircond</i>	Untuk merendahkan suhu sekeliling <i>To lower the surrounding temperature</i>	1+1

## BAB 5 : GELOMBANG / CHAPTER 5 : WAVES

### BAHAGIAN A / SECTION A

Soalan Question	Skema Pemarkahan Marking Scheme	Markah Marks
<b>1</b>	(a) Gelombang membujur <i>Longitudinal waves</i>	1
	sonar ialah gelombang bunyi iaitu gelombang membujur <i>Because sonar is a sound waves which is a longitudinal wave</i>	1
	(b) Frekuensi tinggi <i>High frequency</i>	1
	Mempunyai tenaga tinggi/boleh menembusi lebih dalam ke dalam laut <i>Has high energy/can penetrate deeper into the sea</i>	1
	(c) Laju sangat tinggi <i>very high speed</i>	1
	supaya maklumat yang dipancar dan diterima serta merta <i>informations can be transmitted and received almost immediately</i>	1
	(d) Kuasa penembusan yang tinggi <i>High penetrating power</i>	1
	Boleh menembusi medium lebih senang <i>Can penetrate through medium easily</i>	1
<b>2</b>	(a) Dinding penahan yang diperbuat daripada bahan konkrit / bahan yang lebih kuat / reka bentuk yang lebih kuat / cerun <i>Retaining wall made of concrete / high strength material/slope</i>	1
	Cerun mampu menahan hentaman gelombang / sukar dipatahkan / tahan lama <i>Slope design able to withstand impact of the wave / difficult to break/long lasting</i>	1
	(b) Pintu masuk yang kecil <i>Small gap</i>	1
	Lebih banyak pembelauan berlaku / mengurangkan amplitude / mengurangkan tenaga gelombang <i>More diffraction occurs / reduce wave amplitude / reduce wave energy</i>	1

	(c)	Lokasi jeti terletak di teluk <i>Jetty new location at bay</i>	1
		Gelombang di perairan teluk lebih tenang daripada di kawasan tanjung / keselamatan bot <i>The wave in the bay is calmer than cape region / boat safety</i>	1

### BAHAGIAN B DAN C / SECTION B AND C

Soalan Question	Skema Pemarkahan Marking Scheme	Markah Marks	
<b>1</b>	(a)	- Struktur konkrit, kukuh dan keras <i>Concrete structures, solid and rigid</i>	1
		- Boleh menahan hentakan gelombang, tidak mudah retak <i>Can withstand the impact of the waves, not easy to crack</i>	1
		- Mempunyai celah kecil <i>Has narrow gaps</i>	1
		- Pembelauan akan berlaku, amplitud yang lebih kecil bagi gelombang yang dibelau menyebabkan laut menjadi tenang <i>Diffraction will occur, the smaller amplitude of the diffracted waves causes the sea to be calm</i>	1
		- Harus tinggi <i>Must be high</i>	1
		- Untuk memastikan bahawa tiada limpahan gelombang <i>To ensure no overspill of the waves</i>	1
	(b)	- Jeti yang baru dibina di dalam kawasan teluk <i>The new jetty is built in the region of the bay</i>	1
		- Gelombang dalam teluk adalah lebih tenang (amplitud adalah lebih rendah) daripada tanjung <i>The waves in the bay are calmer (amplitude is lower) than in the cape</i>	1
	(c)	- Tenaga gelombang mencapah di teluk <i>The wave energy diverges at the bay</i>	1
		- Tenaga gelombang menumpu di tanjung <i>The wave energy converges at the cape</i>	1
	- Amplitud dan saiz gelombang adalah lebih kecil di teluk <i>The amplitude and size of the waves are smaller at the bay</i>	1	
		Max 2	

Soalan Question	Skema Pemarkahan Marking Scheme		Markah Marks	
2	Cadangan <i>Suggestion</i>	Sebab <i>Reason</i>		
	Pembesar suara diletakkan jauh antara satu sama lain <i>Loudspeakers are positioned at quite a distance away.</i>	Jarak antara interferens membina interferens memusnah akan jadi pendek <i>So that the distance between consecutive constructive / destructive interference is smaller.</i>		1 + 1
	Dua pembesar suara tidak diletakkan bertentangan antara satu sama lain <i>The two main loudspeakers are not positioned opposite to each other</i>	Mengelakkan pantulan gelombang yang berulang <i>To prevent multiple reflections</i>		1 + 1
	Guna papan lembut / kayu/bahan serap bunyi <i>Fix soft boards / wooden / materials which are sound absorbers</i>	Kesan pantulan gelombang dapat dikurangkan <i>Reflection effects can be reduced</i>		1 + 1
	Guna karpit tebal / lantai kayu / lantai getah <i>Use thick carpet / Wooden floor / Rubber floor</i>	Mengelakkan gema <i>To prevent echo</i>		1 + 1
	Letak pembesar suara ditempat tinggi <i>Assemble the speaker at a high place</i>	Liputan luas / gelombang tidak dihalang <i>Wide coverage / the wave is not blocked</i>		1 + 1

Soalan Question	Skema Pemarkahan Marking Scheme		Markah Marks	
3		Suggestion	Reason	
	(i)	Bahan siling, dinding dan lantai terbuat dari bahan yang menyerap suara / karpet. <i>The material of ceiling, wall and floor are made of materials that absorb sound / carpet.</i>	Menyerap bunyi yang berlebihan <i>Absorb excess sound</i>	1 + 1
		Panel kalis bunyi <i>Soundproof panels</i>	Kurangkan gema <i>Reduce echo</i>	1 + 1
		Gunakan hiasan siling awan yang "terapung". <i>Use ceiling clouds decorative</i>	Menyerap pantulan bunyi <i>Absorb reflection of sound waves</i>	1 + 1
	(ii)	Alas kaunter dan meja dengan kain <i>Cover tables and countertops with tablecloths</i>	Menyerap gema <i>Absorb echo</i>	1 + 1
	(iii)	Pasang tirai penyerap bunyi pada tingkap besar. <i>Areas with large windows, sound absorbing blinds may be installed</i>	Menyerap bunyi dan mengawal gema dari tingkap <i>To capture sound and control reverberations from windows</i>	1 + 1
	(iv)	Buat ruang makan yang jauh dari kawasan dapur <i>Create dining area away from kitchen area</i>	Kurangkan bunyi bising <i>Reduce noise</i>	1 + 1
		Bahagikan kepada kawasan / bilik yang lebih kecil <i>Divide into smaller area / room</i>	Kurangkan gema <i>Reduce echo</i>	1 + 1

## BAB 6 : CAHAYA DAN OPTIK / CHAPTER 6 : LIGHT AND OPTICS

### BAHAGIAN A / SECTION A

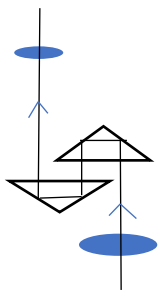
Soalan Question	Skema Pemarkahan Marking Scheme	Markah Marks
<b>1</b>	(a)(i) $1.50 = \frac{\sin 45^\circ}{\sin r}$ $r = 28.13^\circ$	2
	(ii) Ya, kerana sudut tuju lebih besar daripada sudut genting <i>Yes, because incidence angle is greater than critical angle</i>	2
	(b) 	1
	(c)(i) Panjang fokus besar <i>Larger focal length</i> Pembesaran lebih besar <i>Bigger magnification</i>	1  1
	(ii) Diameter lebih besar <i>Bigger diameter</i> Membenarkan lebih cahaya masuk supaya imej lebih cerah <i>Allow more light enter to get clearer image.</i>	1  1

<b>2</b>	(a) 1 per panjang fokus / $\frac{1}{\text{panjang fokus}}$ <i>1 per focal length / <math>\frac{1}{\text{focal length}}</math></i>	1
	(b)(i) $\frac{100}{40} / \frac{1}{0.4}$ 2.5 D	1  1
	(ii) $\frac{100}{10} / \frac{1}{0.1}$ 10 D	1
	(c)(i) Lebih banyak cahaya memasuki kanta / imej lebih cerah <i>More light enter / clearer image</i>	1

	(d)(i)	Besar <i>bigger</i> Pembesaran imej besar <i>bigger magnification of image</i>	1  1
	(ii)	$f_o + f_e$ Imej paling tajam / pelarasan normal <i>Sharpest image / at normal adjustment</i>	1  1

### BAHAGIAN B DAN C / SECTION B AND C

Soalan Question	Skema Pemarkahan Marking Scheme		Markah Marks
1	Modifikasi <i>Modification</i>	Penerangan <i>Explanation</i>	
	Indeks pembiasan lapisan luar adalah lebih rendah daripada indeks pembiasan teras dalam. <i>Refractive index of outer layer is lower than the refractive index of inner core</i>	Supaya pantulan dalam penuh boleh berlaku. <i>So that total internal reflection can happen.</i>	1 + 1
	Kelenturan bahan tinggi <i>High flexibility material</i>	Mudah untuk dibengkok. <i>It can be bent easily.</i>	1 + 1
	Bahan kuat <i>Strong material</i>	Tidak mudah putus. <i>Does not break easily.</i>	1 + 1
	Bahan yang nipis <i>Thin material</i>	Ringan dan boleh digunakan dalam ruang yang kecil. <i>Light and can be used in small area.</i>	1 + 1
	Ketumpatan bahan rendah <i>Low density material</i>	Ringan <i>Light</i>	1 + 1

Soalan Question	Skema Pemarkahan Marking Scheme		Markah Marks	
2	<p style="text-align: center;">Modifikasi <i>Modification</i></p>	<p style="text-align: center;">Penerangan <i>Explanation</i></p>		
	<p>Menggunakan 2 kanta cembung <i>Use 2 convex lenses</i></p>	<p>Sebagai kanta objek dan kanta mata <i>The lenses are objective lens and eyepiece</i></p>		1 + 1
	<p>Kanta dengan panjang fokus yang pendek dan <math>f_o &lt; f_e</math> <i>Short Focal length of both lenses and <math>f_o &lt; f_e</math></i></p>	<p>Untuk mendapatkan pembesaran yang besar. <i>To get a more magnified image</i></p>		1 + 1
	<p>Objek, <math>u</math> diletakkan pada: <math>f &lt; u &lt; 2f</math> <i>Object, <math>u</math> is placed: <math>f &lt; u &lt; 2f</math></i></p>	<p>Mendapatkan imej nyata dan diperbesarkan <i>To get a real and magnified image.</i></p>		1 + 1
	<p>Mikroskop dilengkapi dengan cermin atau mentol. <i>Microscope equipped with mirror or light bulb</i></p>	<p>Untuk menerangi objek <i>To illuminate the object</i></p>		1 + 1
	<p>Lebih daripada satu kanta objek dengan kuasa kanta yang berbeza <i>More than one objective lenses with different power of lenses</i></p>	<p>Boleh memerhatikan tisu-tisu tersebut lebih daripada satu pembesaran. <i>Tissues can be observed with more than 1 magnifications</i></p>		1 + 1

